

T.N. Borovska, Dr. of Sc., assistant professor, J.J. Duda

## GENERALIZATION OF ALGEBRAIC SYNTHESIS METHOD OF CONTROL SYSTEM WITH THE OBSERVER AT OBJECTS WITH A MONOTONE NONLINEAR STATIC CHARACTERISTIC

Is considered a generalization of the problem of synthesis regulator and observer algebraic method on class dynamic objects with monotone nonlinear static characteristic. Prototype - an algebraic method for the control synthesis for the main circuit and the contour of the observer is designed for linear control objects [1]. A significant advantage of the algebraic method is a the absence of operation of finding the roots of the characteristic equations that allows calculating the regulator settings online. A new approach for monotone nonlinear objects allows you to apply algebraic method. The task is a very difficult and known solution are complex and applicable for particular cases. In Fig. 1 is represented by the structure of the system and a list of new challenges that are being addressed in this paper.

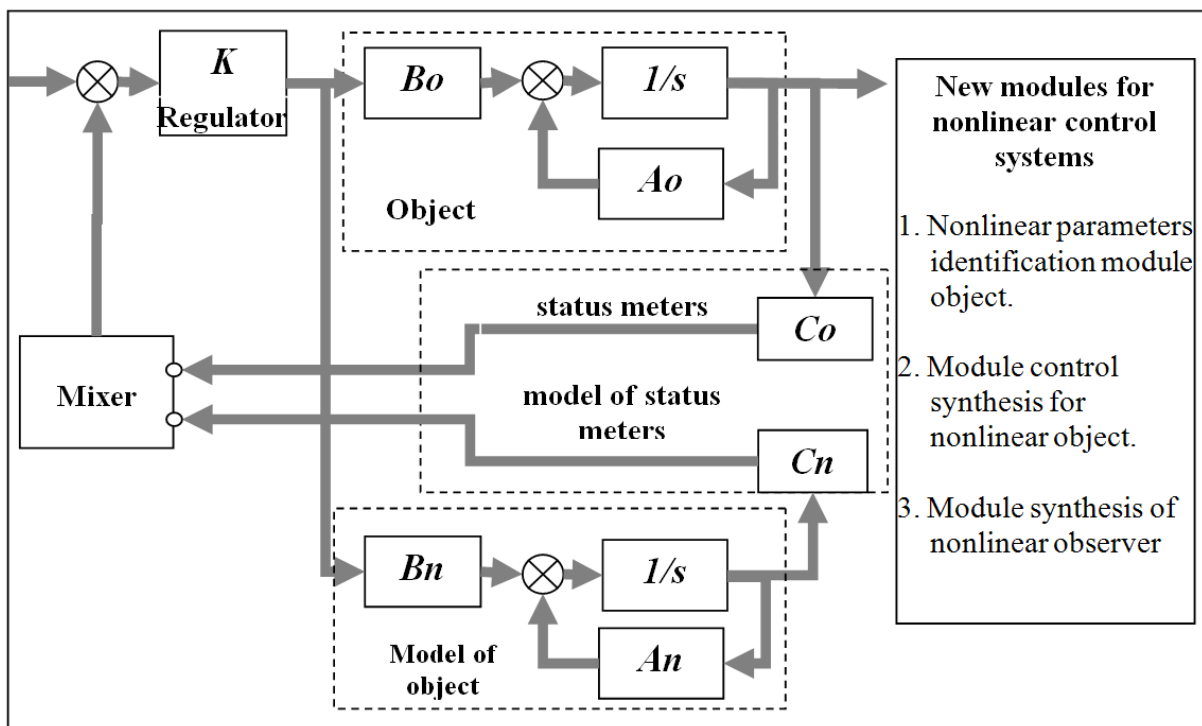

Fig. 1. The structure of nonlinear control system with an observer

Mathematical model of the system implemented in the package Wednesday for modeling and consists of the respective responsibilities of the user:

- object  $Xo^{(k+1)} = Fd(Xo^{(k)}, U^{(k)}, Vp, T)$ ;
- vector measurement vector object state  $Y^{(k)} = C \cdot X^{(k)}$ ;
- object model  $Xn^{(k+1)} = Fd(Xn^{(k)}, U^{(k)}, Vpn, Ld^{(k)}, T)$ ;
- model of measurement vector object state  $Yn^{(k)} = C \cdot Xn^{(k)}$ ;
- regulator of observer's circuit  $Ld^{(k)} = Ls(\Delta Y^{(k)}, C, Vpn^{(k)}, T)$ ;
- regulator of main circuit  $U^{(k)} = Ks(Xm^{(k)}, Vpn^{(k)}, T)$ ;
- mixer of data measures and their assessments by the observer  $Xm^{(k)} = mix(Y^{(k)}, X^{(k)})$ .

The simulation results have confirmed the efficiency and correctness of control system.

### References

1. Borovska, T. N. Modeling and Optimization of Automatic Control / T. N. Borovska, A. S. Vasyura, V. A. Severilov. – Vinnytsia: VNTU, 2009. – 132 c. – ISBN 978-966-641-319-5.