

**R. Obertyuh<sup>1</sup>**  
**A. Slabkyi<sup>1</sup>**  
**O. Polishchuk<sup>1</sup>**  
**O. Hanpanturova<sup>2</sup>**

## HYDROPULSE SMALL-SIZED VIBRATORS BASED ON SLOTTED SPRINGS

<sup>1</sup>Vinnitsia National Technical University

<sup>2</sup>National Technical University of Ukraine «Igor Sikorsky Kyiv Polytechnic Institute»

*The article presents constructions and descriptions of the principles of operation of single-stage pressure pulse generators which are the main elements of the hydropulse drive used to generate vibrations of actuators in vibrating and vibratory shock machines for various purposes. Namely the pressure pulse generator with a solid body the pressure pulse generator with a floating seat and the pressure pulse generator with valve sealing degrees which were developed on the basis of Vinnitsia National Technical University. In the considered devices have the slotted spring as an elastic element which is executed as a separate detail or as a constructive element of other details which are a part of the device is used. The use of such elastic elements allows to ensure the speed of the devices and accordingly to increase the frequency characteristics of their operating modes. It is established that hydropulse vibrators - hydraulic cylinders based on cut or ring springs have the smallest dimensions with significant vibration force parameters. The text of the article highlights the main conditions for stable operation of these pressure pulse generators indicates and analyzes the mathematical dependences between the operating parameters of devices and the size of their structural elements offers the necessary correlation between structural dimensions of working surfaces of actuators and features of their positional parameters. The offered mathematical dependences can be used both for optimization of work of the designs of devices considered in article and at designing of new generators of pressure pulses with the hydropulse drive of various function. The shortcomings of individual designs of pressure pulse generators which may be related to the ways of sealing the working chambers of devices or options for interaction of structural elements of the device are identified and considered.*

**Key words:** pressure, hydropulse drive, hydraulics, vibrations, working liquid, energy carrier, valve, hydraulic cylinder, open spring, rigidity, elasticity.

### Problem statement

Vibration technology equipment with hydropulse drive (HPD) has proven advantages over vibration (VM) and vibration shock (VSM) machines equipped with other types of drives [1-3]. HPD and devices VM and VSM based on it are constantly evolving in particular through the efforts of the HPD Scientific School of Vinnitsia National Technical University (VNTU).

Over the last decade VNTU has created a range of new hydropulse devices and pressure pulse generators (PPG) based on springy elements of high rigidity in particular such as slotted (SS) or annular (AS) springs [4-6]. Using of SS or AS that are combined or part of HPD and PPG power resilience or distribution units allowed to create small-sized high-performance devices for vibrocutting (vibro-sharpening, vibro-drilling, etc.) and surface deformation hardening of parts, as well as single-stage PPG parametric type of increased throughput [7-9].

In order to expand the technical and technological capabilities of devices VM and VSM based on HPD principles of construction of hydropulse devices equipped or built into the distribution elements of their PPG SS can be used to design small enough powerful hydropulse vibrators - hydraulic cylinders (HPV-HC) the power elements of which plungers or pistons combined with the distribution elements of the parametric single-stage PPG.

The field of application of HPV-HC can be varied from the main part of HPD VM and VSM to the use of HPV-HC as a separate vibrating equipment, for example, in the construction industry.

### Main part

Structurally the simplest HPV - HC is shown in Fig. 1. In the solid housing 1 there is a plunger 2, one end of which (upper in Fig. 1) is designed as a rod in contact (affects) with the object of vibration processing (impact in Fig. 1 is not shown) and at the other end (lower in Fig. 1) formed the distribution elements of the sealing stages of parametric single-stage PPG the first with chamfer (valve) sealing with an average diameter  $d_1$  chamfer and the second spool diameter  $d_2$  and a positive overlap  $h_p$ .

The second pool stage of sealing PPG with a diameter of  $d_2$  acts as a power element (piston of the hydraulic cylinder) HPV-HC. Stage of sealing HPV-HC loaded SS 3 installed in the bore of the housing 1 concentrically (coaxially) with the plunger rod 2. Pre-deformation  $y_{01}$  SS 3 is regulated by a tubular screw 4 which is locked with a nut 5. In order to accurately direct the tubular screw 4 the cylindrical surface of its shank on the running landing is coupled with the surface of the direction SS 3 with a diameter of  $d_2$ . The surface of the through axial hole of the tubular screw 4 is in contact with the surface of the plunger rod 2. Sealing of the tubular screw 4 and the rod of the plunger 2 is carried out by rubber rings of round section (in Fig. 1 not conditionally marked with positions). In order to reduce the requirements for the accuracy of the conjugation of the surfaces of the plunger rod 2 and the axial hole of the tubular screw 4 sealing rings can be installed in the grooves together with split fluoroplastic rings to protect rubber rings from destruction due to compression.

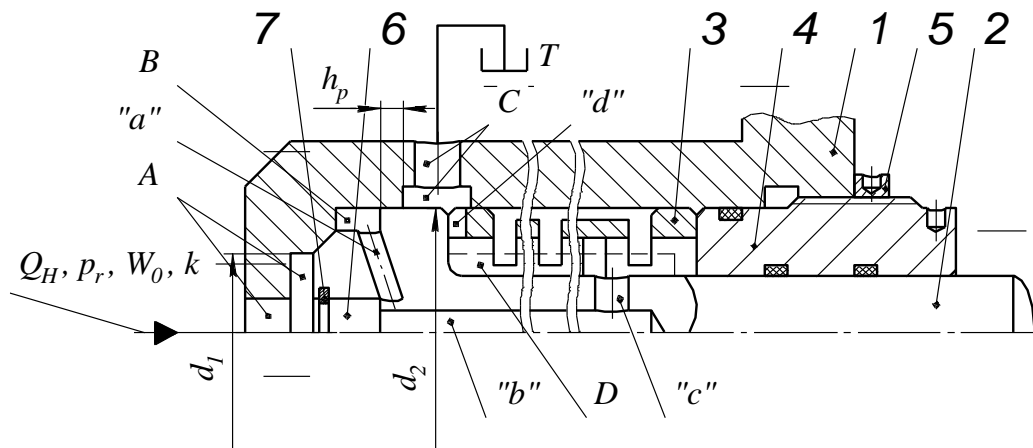

Fig. 1. HPV - HC with a solid body

To ensure the optimal mode of closing PPG HPV - HC at the end of the return stroke of the plunger 2 in the blind central stepped axial hole of the plunger 2 from the first stage of sealing PPG placed inertial valve 6 fixed by a split spring ring 7. The valve 6 has a stepped cylindrical shape to a lesser extent which forms a sealing conical chamfer and its larger cylindrical stage on the running landing mates with the surface of the larger diameter of the central stepped axial hole in the plunger 2. The seat for the valve 6 is designed in the transition from a larger diameter to a smaller (hole "b") central stepped axial hole in the plunger 2.

The working fluid (energy carrier) from the hydraulic pumping station (not shown in Fig. 1) is fed into the pressure cavity A HPV - HC. For reaching the energy pressure in cavity A  $p_A \geq p_{1max}$  (PPG "opening" pressure),

$$p_{1max} \geq (k_{SS} \cdot y_{01} + F_{TR} + m_{max} \cdot g) \cdot A_1^{-1}, \quad (1)$$

(here  $k_{SS}$  – stiffness SS 3;  $F_{TR}$  - the initial force of technological resistance of the object of influence HPV - HC;  $m_{max}$  – maximum inertial mass of the executive link of the technological machine, which is driven into vibration;  $g = 9.8 \text{ m/s}^2$  – acceleration of free fall;  $A_1 = 0.25 \cdot \pi \cdot d_1^2 \approx 0.785 \cdot d_1^2$  – cross-sectional area of the locking element of the first stage of PPG sealing (see Fig. 1)), PPG tightness is broken plunger 2 defeating the initial effort  $F_{0max} = k_{SS} \cdot y_{01} + F_{TR} + m_{max} \cdot g$  begins to move cavities A and B (intermediate cavity PPG) are connected and the energy pressure  $p_B = p_A$  in these cavities due to the small volume of cavity B almost instantly reaches the level of  $p_{1max}$  and acts on the entire cross-sectional area  $A_2 = 0.25 \cdot \pi \cdot d_2^2 \approx 0.785 \cdot d_2^2$  second degree PPG sealing. It should be noted that at the pressure level of the energy carrier  $p_A < p_{1max}$  inertial valve 6 moves up (according to Fig.1) and is fixed on the saddle thus separating the intermediate B from the drain C cavities which are interconnected through oblique holes "a", hole "b", radial hole "c", cavity D placement of SS 3 and transverse grooves "d" in SS 3.

During the action of the energy carrier  $p_{1max}$  on the area  $A_2$  of the plunger 2 the latter moving passes a positive overlap  $h_p$  and opens the second stage of sealing PPG to the value of the negative overlap  $h_n$ . In the first approximation we can take  $h_n \leq h_p$ . Full stroke of the plunger 2  $h = h_p + h_n$  is its working course and essentially the amplitude of vibrations. For relatively small values  $F_{TR}$  i  $m_{max}$  real workflow  $h_p > h$  due to the inertial movement of the plunger 2 in order to prevent delaying the process of closing the PPG HPV-HC it is advisable to limit the stroke  $h_p$  of the plunger 2 by performing on its surface an additional cylindrical stage (Fig. 1 this stage is shown by a dashed line).

After passing the plunger 2 negative overlap  $h_n$  cavities A and C are connected (see Fig. 1) and the flow of energy enters the tank  $T$  hydraulic pumping station of the drive HPV – HC. Energy pressure in cavities A and B decreases to the level of "closing" pressure PPG [3]

$$p_A \leq p_{2max} \leq p_{1max} \cdot d_1^2 \cdot d_2^{-2} + (k_{SS} \cdot h + F_{Tmax} + m_{max} \cdot g) \cdot A_2^{-1}, \quad (2)$$

where  $F_{Tmax}$  – maximum strength of technological resistance of the object of influence HPV – HC. Under the action of force  $F_{max} = k_{SS} \cdot h + F_{Tmax} + m_{max} \cdot g$  plunger 2 starts reverse passes negative overlap  $h_n$  and during its movement in the path of positive overlap  $h_p$  small increase in energy pressure  $p_B > p_C$  (here  $p_C \approx p_{dr} \approx 0$  – energy carrier pressure in the drain cavity  $C$ ) in the intermediate cavity  $B$  causes the opening of the inertial valve 6 which causes a clear fixation of the first degree of sealing PPG on the seat. Then the cycle is repeated.

Usually  $m_{max}$  consists of masses of a moving vibrating table VM (or VSM), device with the object of technological influence, moving link of HPV – HC (in this case the plunger 2) and others connected to the vibrating table, moving links of VM (or VSM). The power of weight  $G_{max} = m_{max} \cdot g$  is advisable to take into account the vertical location of the plunger 2 and the value of  $m_{max}$  mainly affects the level of its inertial displacement.

The main disadvantage of this design HPV - HC is the possible shock interaction of the first stage of sealing PPG at the end of the return stroke of the plunger 2 when landing its sealing element on the saddle with a medium diameter chamfer  $d_1$  which can reduce the life of the vibrator and cause a high level of noise during its operation.

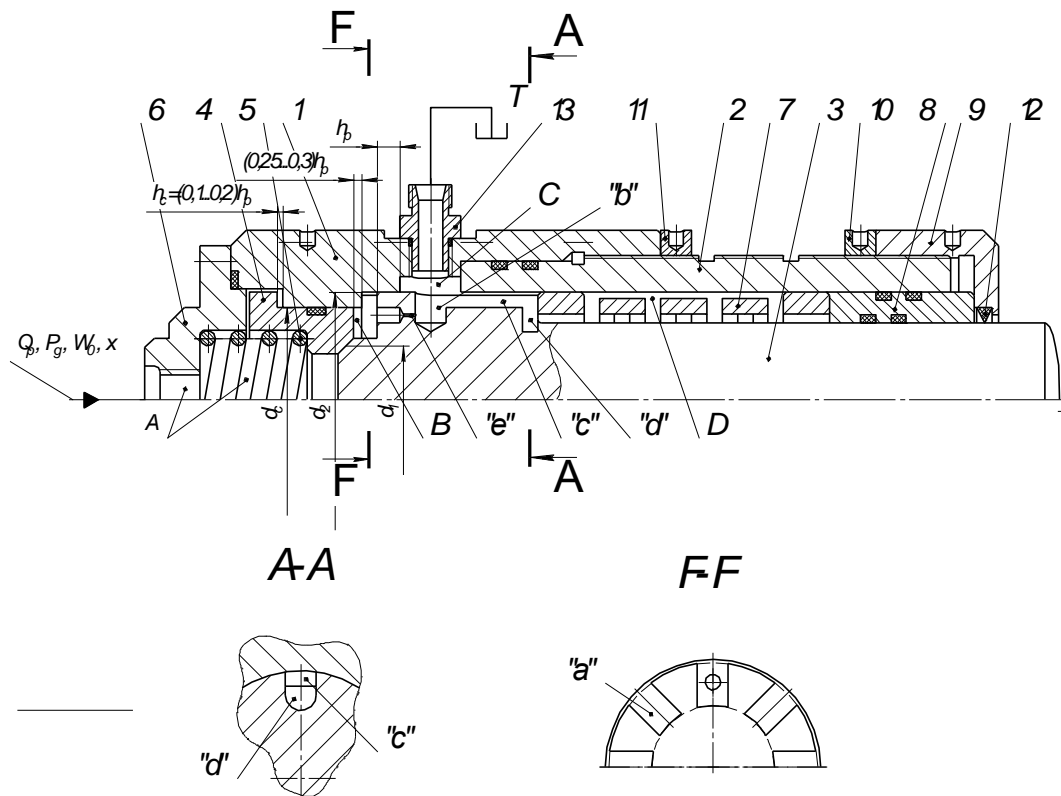

Fig. 2. HPV - HC with floating PPG saddle

These shortcomings are less in HPV - HC the structural scheme of which is shown in Fig. 2. The housing of the vibrator consists of two parts - cylinder 1 and sleeve 2, connected by cutting on the outer surface of the sleeve 2 and the inner surface of the shaft of the cylinder 1, which is essentially the housing of PPG HPV - HC. Plunger 3 is structurally similar to plunger 2 (see Fig. 1) on the left end of which (Fig. 2) formed PPG sealing elements: of the first degree - chamfered with a medium diameter  $d_1$ ; the second is a spool with a diameter of  $d_2$  which simultaneously acts as a power piston of the vibrator.

Spool stage of sealing PPG with step bore of cylinder 1 with diameter "c" in the initial position forms a positive overlap  $h_p$ . At the end of the spool stage of sealing PPG made 8 radial grooves "a" with depth  $h_g = h_p$  and outer diameter  $d_g < d_2$  (for sample  $d_g = d_2 - 3 \text{ mm}$ ). The end part of the plunger 3 in its initial position rests on the bottom of the bore of the cylinder 1 with a diameter  $d_2$ .

The chamfered part of the first stage of PPG sealing is in contact with the floating saddle 4 of the cylindrical shape. Saddle 4 is mated to the running landing with a through bore with a diameter  $d_c$  in cylinder 1. The contact surface of the saddle 4 with the bore of the cylinder 1, in order to increase the tightness, additionally sealed with a rubber ring of circular cross-section with two split fluoroplastic rings (in Fig. 2 not marked positions). The seat 4 to the chamfer of the first stage of PPG sealing is pressed by a twisted spring 5 located in the inner bores of the seat 4 and the cover 6 of the energy supply to the pressure cavity A HPV – HC. At the left end (Fig. 2) of the saddle 4 made a cylindrical protrusion (collar) with a diameter  $d_p > d_c$ . Between the inner end of which and the bottom of the bore in the cylinder 1 in the initial position of the saddle 4 formed a gap  $h_c = (0,1...0,2) h_p$  (see Fig. 2) which is slightly smaller than the gap  $(0,25...0,3)h_p$  between the left (according to Fig. 2) end of the saddle 4 and the end of the second spool stage of PPG sealing in the initial position.

SS 7 is placed in the through central bore of the sleeve 2 coaxially with the rod of the plunger 3. Preliminary deformation  $x_{01}$  SS 7 adjusted through the sleeve 8 by a cap nut 9, which is counted by a nut 10. The bushing 8 is sealed in the sleeve 2 and on the rod of the plunger 3 rubber rings of round cross section (in Fig. 2 are not marked with positions). The threaded connection of the cylinder 1 and the sleeve 2 is counted with a nut 11. The rod of the plunger 3 from external contamination is protected by dirt-pan 12 located in the bore of the cap nut 9.

The principle of operation of this HPV - HC is similar to the principle of operation of the vibrator presented on Fig. 1, but there are some features. During the increase of the energy pressure in the pressure cavity A to the level

$$p_A = p_{10} \geq (k_{SS} \cdot x_{01} + F_{TR} + m_{\max} \cdot g - k_{SS} \cdot x_{02}) \cdot A_0^{-1}, \quad (3)$$

(here  $k_{SS}$  - rigidity SS 7;  $F_{TR}$  - the initial strength of the technological resistance of the object of influence HPV-HC;  $m_{\max}$  - maximum inertial mass of the executive link of VM (or VSM);  $g = 9.8$  m/s<sup>2</sup> (power  $G_{\max} = m_{\max} \cdot g$  should be considered for the vertical position of the vibrator);  $A_0 = 0.25 \cdot \pi \cdot d_c^2 \approx 0.785 \cdot d_c^2$  - the cross-sectional area of the saddle 4 in diameter  $d_c$ ,  $k_{SS} \cdot x_{02}$  - respectively the rigidity and pre-deformation of the twisted spring 5) the saddle 4 together with the plunger 3 moves in the path of the gap  $h_c$  to the stop of the saddle 4 with its collar at the end of the bore in the cylinder 1 (see Fig. 2) and short-term (almost instantaneous) stop the movement of the plunger 3. The opening of the first stage of sealing PPG (leakage) will occur with the next increase in energy pressure in cavity A to the level

$$p_{1\max} \geq [k_{SS}(x_{01} + h_c) + F_{T0} + m_{\max} \cdot g] \cdot A_1^{-1}, \quad (4)$$

where  $A_1 = 0.25 \cdot \pi \cdot d_1^2 \approx 0.785 \cdot d_1^2$  - the cross-sectional area of the locking element of the first stage of PPG sealing (see Fig. 2). Next the operating cycle of the considered HPV-HC is carried out similarly to the cycle of the previously described vibrator (see Fig. 1).

The intermediate cavity B of this vibrator includes the volume of the grooves "a", and the drain cavity C is connected through the fitting 13 to the tank T of hydraulic pumping station (conditionally not shown in Fig. 2). Cavity D placement SS 7 through the grooves "d", "c" and the blind hole "b" in the plunger 3 is freely connected to the drain cavity C.

The reverse mode of the plunger 3 begins with a decrease in the cavities A and B of the energy pressure to the level  $p_{2\max}$  "closing" of PPG [3] which is calculated by formula (2). At the end of the return stroke of the plunger 3 due to the springy installation of the seat 4 is soft braking of the plunger 3, which significantly reduces its impact interaction with the end (bottom) of the step bore with a diameter  $d_2$  in the cylinder 1. The optimal mode of completion of the return stroke of the plunger 3 is regulated by a throttle hole "e" with a diameter  $d_{th}$ . Instead of the hole "e" the throttle of "landing" of the plunger 3 can be formed due to the gap in the conjugate cylinder 1 and the plunger 3 in diameter  $d_2$  or coot on the spool surface of the plunger 3.

Preliminary deformation of the twisted spring 5  $x_{02} = \text{const}$  is installed during installation (assembly) of the vibrator. Since  $A_0 > A_1$  then it follows from the comparison of dependences (3) and (4) that  $p_{1\max} \approx p_{10} \cdot A_0 \cdot A_1^{-1}$  and  $p_{1\max} > p_{10}$ . This confirms the instantaneous stop of the plunger 3 at the end of its movement during a straight distance  $h_c$ .

Spool second stage PPG sealing (see Fig. 1 and Fig. 2) due to the presence of a positive overlap  $h_p$  reduces the frequency of vibrations due to the time spent on the passage of this overlap, and for the same reason does not allow to obtain the amplitudes  $h_a$  of vibrations less than the stroke  $h = h_p + h_n$  of actuators (plungers 2 and 3) vibrators. For some vibration technologies for example vibropressing of products from ultra-dispersed

powder materials [10] high frequency  $\nu$  (HC) and small amplitude  $h_a = (0,1...0,4) \cdot 10^{-3}m$  of vibrations are crucial.

To some extent, this problem can be solved with HPV-HC, the structural diagram of which is shown in Fig. 3. The first and second stages of PPG sealing in this vibrator are valve (chamfered) which allows to limit the working stroke of the actuator of the vibrator  $h_p \approx h_n$  ( $h_n$  - negative overlap of sealing stages PPG) and increase the frequency of vibrations.

HPV-HC consists of a saddle housing 1 PPG connected to the sleeve 2 placement SS 3 by means of flanges 4 and 5, half rings 6, coupling bolts (runners) 7, nuts 8 and spring washers 9. On the left end of the plunger 10 (according to Fig. 3) made a valve type (chamfer) locking element of the first stage of sealing PPG vibrator which is ground to a wide chamfer of medium diameter  $d_1$  is in contact with the first chamfer of the saddle body 1. The second stage of sealing PPG is formed by means of a bushing-valve 11 which is directed to the exact running fit for example  $\varnothing d_1 H7/g6$  in diameter  $d_1$  of the cylindrical part of the locking element of the sleeve-valve 11 of the vibrator. At the left end of the bushing-valve 11 is made of a wide chamfer which on the average diameter  $d_2$  is in contact with the second chamfer of the seat body 1. Contact pressure  $p_c$  which is required for sealing in the initial position of the bushing-valve 11 on the second facet of the seat housing 1 is created by a twisted spring 12 which presses the bushing-valve 11 to the seat through the stepped sleeve 13 and the split spring ring 14:

$$p_c = 4k_{12} \cdot x_{02} / \pi \cdot d_2^2 \approx 1.274k_{12} \cdot x_{02} \cdot d_2^{-2}, \quad (5)$$

where  $k_{12}$ ,  $x_{02}$  - rigidity and preliminary deformation of the twisted spring 12 ( $x_{02} = \text{const}$  - because this deformation is created during the assembly of the vibrator).

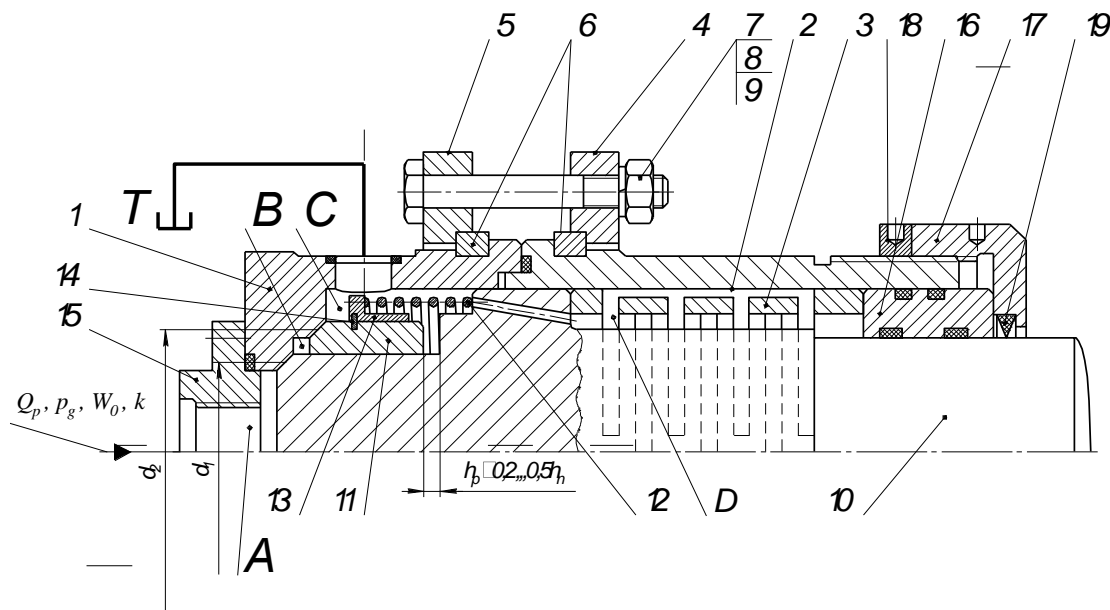

Fig. 3. HPV-HC with valves of PPG sealing

The opening of PPG of this HPV-HC as in those considered in Fig. 1 and fig. 2 vibrators begins when the pressure level "opening" is reached in the pressure cavity A  $p_{I\max}$  calculated by the formula identical to (1) all values in which have the same meaning as in dependences (1) and (4). During the connection of cavities A and B and almost instantaneous equalization of the energy pressure in them (due to the small volume of cavity B) at the level  $p_{I\max}$  the bushing-valve 11 overcoming the resistance of the twisted spring 12 moves rapidly in the path of the gap  $h_c = (0,2...0,5)h_n$  and its right (Fig. 3) flat end rests on the end of the intermediate protrusion (see Fig. 3) of the plunger 10 and then moves with it to the full opening on the working stroke  $h_p \geq h_n$  PPG of vibrator. Due to the opening of the PPG the pressure head A and the drain cavity C are connected. The drain cavity C through the hole "b" and the angular drain nipple 15 is connected to the tank B of the hydraulic pumping station (Fig. 3 is not shown).

Cavity D of placement SS 3 is freely connected through oblique holes "a" with the drain cavity C. Developed length and high accuracy of the guide surface ( $\varnothing d_1 H7/g6$ ) of the bushing-valve 11 virtually eliminate energy losses due to the gap in the coupling of the bushing-valve 11 and the cylindrical part of the locking element of the first stage of sealing PPG HPV-HC during the direct stroke of the plunger 10.

Energy pressure level  $p_{1\max}$  is adjusted through the sleeve 16 by the cap nut 17 which is counted by a nut 18. The rod of the plunger 10 from external contamination is protected by a dirt remover 19.

The return stroke of the plunger 10 begins with a decrease of the energy pressure in the cavity A to the level (pressure "closing" PPG)

$$p_A \leq p_{2\max} \leq p_{1\max} \cdot d_1^2 \cdot d_2^{-2} + \left[ k_{SS} \cdot h_p + F_{T\max} + m_{\max} \cdot g + k_{12}(x_{02} + h_c) \right] \cdot A_2^{-1}, \quad (6)$$

where  $A_2 = 0.25 \cdot \pi \cdot d_2^2 \approx 0.785 \cdot d_2^2$ . Other values in formula (6) have the same values as in (2).

After reversing  $h_p$  the locking elements of the first and second stages of sealing the PPG vibrator are fixed in the initial position and the operating cycle is repeated.

According to the known dependence [3] growth time  $t_i$  of energy carrier pressure in the pressure cavities of the considered HPV - HC (see Fig. 1 - Fig. 3):

$$t_i \approx \Delta p \cdot W_0 \cdot (Q_p \cdot k)^{-1}, \quad (7)$$

where  $\Delta p = p_{1\max} - p_{2\max}$ ;  $W_0$  - the initial volume of the pressure cavity A;  $Q_p$  - supply of the hydraulic pump of the hydraulic pumping station;  $k$  - isothermal modulus of elasticity of the energy carrier. Time  $t_i$  is one of the main components that determines the frequency of the pressure pulses in the cavity A which is equal to the vibration frequency  $\nu_T \equiv \nu$  [1-4]:

$$T_p = \nu^{-1} = K_{CP} t_i, \quad (8)$$

where  $T_p$  - period of oscillations of pressure pulses;  $K_{CP}$  - cyclic pressure pulse coefficient which is determined by the time components of the pulse including the duration of the front  $t_i$  and back  $t_d$  pulse fronts are decisive ( $t_i > t_d$ ) [7]. Time  $t_d$  depends on the level of conditional passage of PPG and the switching speed of the generator, which is virtually unadjustable and time  $t_i$  (see (8)) can be changed by affecting  $\Delta p$  (due to regulation  $p_{1\max}$ ) and  $Q_p$  for example by diverting part of this energy carrier flow through the flow regulator into the tank [1-3]. Changing of  $\Delta p$  mainly affects the level of vibration amplitude and useful force on the rod HPV-HC.

Execution in the last of the considered designs of HPV-HC of the first and second stages of sealing of PPG as valve (chamfered see fig. 3) besides the noted advantages allows to increase cross section PPG of this vibrator due to boundary increase in rigidity SS 3 (short spring) provided ensuring its strength.

## Conclusions

According to the results of the study on the development of small hydropulse vibrators based on open-air springs, the following conclusions can be drawn:

1. Based on the analysis of basic and structural schemes of vibrators with different types of drives, namely: mechanical, electrical, pneumatic and hydraulic, it is established that hydropulse vibrators - hydraulic cylinders (HPV-HC) based on SS or AS have the smallest dimensions with significant vibration power parameters.
2. HPV-HC can be used as the main part of GPD VM and VSM, in which the functions of PPG and hydraulic motor (hydraulic cylinder) are combined in one design, and as independent hydraulic devices.
3. Minimization of the dimensions of HPV-HC is achieved by using short SS (or AS), the stiffness of which is determined by the allowable stresses in the elements of the springs occurring in the cross sections of SS (or AS) at their maximum possible loads, and reducing the stroke of the GPP HPV-HC power unit, by eliminating spool sealing (positive overlap  $h_n$ ) at both stages of PPG sealing (changes in the area of shut-off elements) by applying bevel (valve) sealing of these stages, allows you to build HPV-HC with a wide range of amplitude and vibration frequency.

## REFERENCES

- [1] Іскович-Лотоцький Р. Д. Процеси та машини вібраційних і віброударних технологій : монографія / Іскович-Лотоцький Р. Д., Обертюх Р. Р., Архипчук М. Р. Севостьянов І. В. – Вінниця : УНІВЕРСУМ – Вінниця 2006. – 291 с.
- [2] Іскович-Лотоцький Р. Д. Використання гідроімпульсного привода в обладнанні переробних виробництв : монографія / Іскович-Лотоцький Р. Д., Обертюх Р. Р., Поліщук О. В. – Вінниця : VNTU, 2008. – 116 с.
- [3] Іскович-Лотоцький Р. Д. Генератори імпульсів тиску для керування гідроімпульсними приводами вібраційних та віброударних технологічних машин : монографія / Іскович-Лотоцький Р. Д., Обертюх Р. Р., Архипчук М. Р. – Вінниця : УНІВЕРСУМ – Вінниця, 2008. – 171 с.
- [4] Обертюх Р. Р. Пристрої для віброточіння на базі гідроімпульсного привода : монографія / Р. Р. Обертюх, А. В. Слабкий. – Вінниця : VNTU, 2015. – 164 с.
- [5] Обертюх Р. Р. Віброударний пристрій з гідроімпульсним приводом підвищеної швидкодії та ефективності для деформаційного зміцнення поверхонь деталей машин / Обертюх Р. Р., Слабкий А. В., Марущак М. В. // Вісник машинобудування та транспорту, м. Вінниця № 1, 2017. – С. 63 – 71.
- [6] Обертюх Р. Р. Пристрої для вібраційного різання та деформаційного зміцнення з пружними елементами високої

жорсткості / Обертюх Р. Р., Слабкий А. В. // Матеріали (тези) XVI Міжнародної науково-технічної конференції «ВІБРАЦІЇ В ТЕХНІЦІ ТА ТЕХНОЛОГІЯХ» (Вінниця, листопад 2017 р.). – С. 68 – 71.

[7] Obertyuh R. R. Method of design calculation of a hydropulse device for strain hardening of materials / Obertyuh R. R., Andriy V. Slabkiy, Mykhailo V. Marushchak, Oleksandr V. Kobylanskiy, Waldemar Wojcik, Gulzada Yerkeldessova, Yerbol Turgyzbekov // Przeglad elektrotechniczny Vol 2019, № 4, 65-73.

[8] Обертюх Р. Р. Параметричні однокаскадні генератори імпульсів тиску підвищеної пропускну здатності / Обертюх Р. Р., Слабкий А.В., Андрухов С.Р., Кудраш В.О. // Вісник машинобудування та транспорту – №1, 2019. – С. 40 – 48.

[9] Пат. 141848 У, Україна, F15B21/00, / (Україна). Однокаскадний генератор імпульсів тиску підвищеної пропускну здатності / Обертюх Р. Р., Слабкий А.В., Поліщук О.В., Кудраш О.В. Заявл. 07.11.2019; – Опубл. 27.04.2020, Бюл. №8/2020, 27.04.2020р.

[10] Раковский В. С. Порошковая металлургия жаропрочных сплавов и тугоплавких материалов / В. С. Раковский, А. Д. Силаев, В. И. Ходкин и др. – М : Металлургия, 1984. – 184 с.

**Obertyuh Roman** – Ph. D. (Eng), Associate Professor, Professor of department of industrial engineering, e-mail: [obertyuh557@gmail.com](mailto:obertyuh557@gmail.com)

**Slabkiy Andrii** – Ph. D. (Eng), Associate Professor, Associate Professor of department of industrial engineering, e-mail: [slabkiyandrey@gmail.com](mailto:slabkiyandrey@gmail.com)

**Polishchuk Olexandr** – Ph. D. (Eng), Associate Professor, Associate Professor of Department of Life Safety, e-mail: [A\\_V\\_Polishchuk@ukr.net](mailto:A_V_Polishchuk@ukr.net)

Vinnitsia National Technical University, Vinnitsia

**Hanpanturova Oksana** – Ph. D. (Eng), Associate Professor, Associate Professor at Department of Fluid Mechanics and Mechatronics, e-mail: [ganpanturova@ukr.net](mailto:ganpanturova@ukr.net)

National Technical University of Ukraine “Igor Sikorsky Kyiv Polytechnic Institute”, Kyiv

**Р. Р. Обертюх<sup>1</sup>**  
**А. В. Слабкий<sup>1</sup>**  
**О. В. Поліщук<sup>1</sup>**  
**О. С. Ганпанцурова<sup>2</sup>**

## Гідроімпульсні малогабаритні вібратори на базі прорізних пружин

<sup>1</sup>Вінницький національний технічний університет

<sup>2</sup>Національний технічний університет України «Київський політехнічний інститут імені Ігоря Сікорського»

В статті наведені конструкції та описи принципів роботи однокаскадних генераторів імпульсів тиску, що є основними елементами гідроімпульсного приводу який використовується для генерування вібрацій виконавчих органів у вібраційних та віброударних машинах різного призначення. А саме генератора імпульсів тиску із суцільним корпусом, генератора імпульсів тиску із плаваючим сідлом та генератора імпульсів тиску із клапанними ступенями герметизації, що були розроблені на базі Вінницького національного технічного університету. В розглянутих пристроях в якості пружного елемента використовується прорізна пружина, що виконана як окрема деталь або як конструктивний елемент інших деталей, які входять до складу пристрою. Використання таких пружних елементів дозволяє забезпечити швидкодію пристроїв та, відповідно, підвищити частотні характеристики їх робочих режимів. Встановлено, що гідроімпульсні вібратори – гідроциліндри на базі прорізних чи кільцевих пружин мають найменші габарити за значних вібраційних силових параметрів. В тексті статті висвітлено основні умови стабільної роботи наведених генераторів імпульсів тиску, вказано та проаналізовано математичні залежності між робочими параметрами пристроїв та розмірами їх конструктивних елементів, запропоновано необхідні співвідношення між конструктивними розмірами робочих поверхонь виконавчих елементів та особливості налаштування їх позиційних параметрів. Запропоновані математичні залежності можуть бути використані як для оптимізації роботи розглянутих в статті конструкцій пристроїв, так і під час проектування нових генераторів імпульсів тиску з гідроімпульсним приводом різного призначення. Виявлені та розглянуті недоліки окремих конструкцій генераторів імпульсів тиску, що можуть бути пов'язані із шляхами герметизації робочих камер пристроїв або варіантами взаємодії конструктивних елементів пристрою та запропоновано конструктивні рішення для усунення або мінімізації їх впливу на якість роботи генераторів імпульсів тиску.

**Ключові слова:** тиск, гідроімпульсний привод, гідравліка, вібрації, робоча рідина, енергоносіє, клапан, гідроциліндр, прорізна пружина, жорсткість, пружність.

**Обертюх Роман Романович** – канд. техн. наук, доцент, професор кафедри галузевого машинобудування, e-mail: [obertyuh557@gmail.com](mailto:obertyuh557@gmail.com)

**Слабкий Андрій Валентинович** – канд. техн. наук, доцент, доцент кафедри галузевого машинобудування, e-mail: [slabkiyandrey@gmail.com](mailto:slabkiyandrey@gmail.com)

**Поліщук Олександр Васильович** – канд. техн. наук, доцент, доцент кафедри безпеки життєдіяльності та педагогіки безпеки, e-mail: [A\\_V\\_Polishchuk@ukr.net](mailto:A_V_Polishchuk@ukr.net)

**Ганпанцурова Оксана Сергіївна** – канд. техн. наук, доцент, доцент кафедри прикладної гідроаеромеханіки і механотроніки, e-mail: [ganpanturova@ukr.net](mailto:ganpanturova@ukr.net)