

ПРИЛАДИ І СИСТЕМИ БІОМЕДИЧНИХ ТЕХНОЛОГІЙ

УДК 621.317: 621.37:612.84

LOW-INTENSITY SIGNAL MODULATION OF THE MICROWAVE
PHYSIOTHERAPY EQUIPMENT¹⁾Yanenko O., ¹⁾Peregudov S., ¹⁾Shevchenko K., ²⁾Kychak V.¹⁾National Technical University of Ukraine "Igor Sikorsky Kyiv Polytechnic Institute",
Kyiv, Ukraine²⁾Vinnitsia National Technical University, Vinnitsia, UkraineE-mail: op291@meta.ua

The article describes the features of the amplitude and frequency modulation of the output signals of millimeter range generators for microwave therapy. A review of the appearance of possible biological and medical effects using modulated signals is carried out. The use of highly sensitive radar-type equipment made it possible to study the absorption capacity of a person in the mm-wave range from an external source.

The authors's results of experimental studies are described, this are showed that at some frequencies, an increased absorption of the power of the irradiating signal is recorded. These frequencies are referred to as "absorption resonances". The original schemes of monochromatic and noise signal generators developed by the authors are presented, and the principle of their operation is described. The article shows the possibility of generating low-intensity signals and ensuring the generator range operation using the second harmonic of the monochromatic signal and the selective properties of the EHF nodes. The technical parameters and characteristics of the developed devices are revealed. The application areas of the developed devices in practical medicine are out-lined. With the help of the control unit, a low-frequency signal as a saw-like or triangular voltage is generated and is supplied to the varactor converter. Under the influence of the modulation signal, the varactor capacitance changes, and, therefore, the frequency of the EHF generator. The operation of a combined radiation measurement system with a modulated noise-like output spectrum and the patient feedback is described.

The article demonstrates the broad practical possibilities for using microprocessor technology for automation and control of the operation mode selection process, for the formation and change of the microwave signal modulation parameters. The conducted studies reveal the process of interaction of low-intensity microwave radiation with the human body and can be used in technologies of millimeter therapy. The article describes the service functions of the developed equipment, which contribute to its more effective use in microwave therapy technologies.

Keywords: millimeter therapy; low-intensity signals; microwave generators; signal modulation.

Introduction

Two types of modulation are typically used in medical devices for microwave (millimeter) therapy – amplitude and frequency modulation. Amplitude modulation is carried out by low-frequency pulses F_{mod} up to 100 Hz, using an electrically guided attenuator on *p-i-n* diodes. The shape of the modulation pulses can be different – rectangular (meander), triangular, saw-like, etc. Modulation with rectangular pulses of both monochromatic, and millimeter range noise signals is used more often in practice. The use of modulation low frequency is argued by the existence of biological rhythms (frequencies) in the organism, the convergence of which can raise treatment effectiveness.

The examination of the influence of modulated signals of the low, high, and ultrahigh frequencies and their combinations on the brain tissue, conducted in [1] allowed to reveal some features, which are as follows:

- low-frequency modulation of EHF signals (amplitude-harmonic, or pulse modulation) leads to the appearance of clear biological effects;
- the frequency range of the brain tissue maximal sensitivity varies between the frequency window interval of 6...20 Hz;
- the biological influence is observed in certain energy windows and weakens with the increase of the radiating field level by two orders;
- the impact of the modulated EHF signal with a modulation frequency of 6...16 Hz guarantees the maximal release of the biological ion objects $^{45}\text{Ca}^{2+}$ from the brain tissue. Using the frequency less than 6 Hz and more than 16 Hz led to the decrease of ions release;
- biological influence of the weak fields is explained by cooperative processes, which are based on imbalanced resonant distant interactions of the biological macromolecules.

No less interesting are the effects of the electromagnetic EHF fields influence, including ones modulated by a low frequency, which were found during the experimental radiation of the human and animal acupuncture points with the aforementioned signals [1]:

- organism reflex response to a local microwave influence is aimed at normalization of natural or artificially-created organism disorders, which is typical for the organism response to the influence of different factors on the acupuncture points;
- at the low and middle intensity of the microwaves a reflex response is observed while influencing with a modulated EHF signal;
- a biologically active frequency band of a pulse microwave modulation varies between 0,1...100 Hz with optimums at 6...8 Hz for humans, and 1 Hz for animals;
- in the mode of continuous generation, a reflex response occurs at the high microwave intensity, which is accompanied by an increase of a tissue temperature level.

Thus, we can assume that a low-frequency modulation allows to reduce the level of EHF signal while keeping the treatment effectiveness, and a combined low-intensity signal guarantees bio-informational impact.

The features of the microwave signal modulation

The typical implementation scheme of the EHF signal amplitude modulation is shown in Fig. 1, *a*.

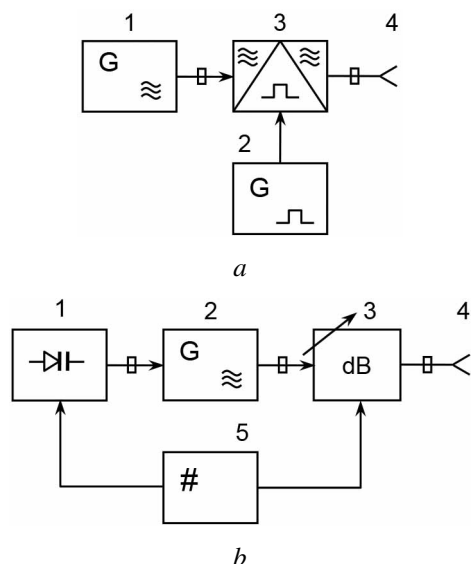

Fig. 1. The modulation implementation scheme: amplitude modulation (*a*); frequency modulation (*b*)

A block diagram shows:

- 1 – mm-length generator;
- 2 – low-frequency generator of the modulation signal;
- 3 – amplitude modulator (attenuator) on a *p-i-n* diode;
- 4 – output antenna.

Low-frequency pulses F_{mod} from the generator (2) are given to a modulator input (3) and periodically ($\frac{1}{2} T_F$) reduce (module) the amplitude of the EHF generator (1) output signal. The modulation frequency is selected by the generator (2) according to objective and subjective criteria of the treatment process or according to a final assessment of the treatment effectiveness [2, 3].

Amplitude modulation is used both in monochromatic signal devices, for example, “Elektronika-KVCH-011” (“Электроника-КВЧ-011”), “RAMED-Expert” (“РАМЕД-Эксперт”), and in noise signal generators “Stella-1” (“Стелла-1”), “Artsakh-04M” (“Арцах-04М”). Modulation frequency can be fixed — 9 Hz, for example in “Stella-1” (“Стелла-1”), or can vary between 0,1...250 Hz, for example in “Artsakh-04M” (“Арцах-04М”). A device “Elektronika-KVCH-011” (“Электроника-КВЧ-011”) has rectangular pulse modulation modes with a frequency of $F_{\text{mod}} 2...90$ Hz [2].

A frequency modulation mode is widely used in the devices for microwave resonance therapy. This mode is often introduced in devices with a monochromatic signal to create an effect of a pseudo-noise signal. Such mode is used in devices “ARIA-SC” ($\Delta F = 20$ and $\Delta F = 200$ МГц), “AMT-Kovert-04” (“АМТ-Коверт-04”) and devices of the series “Yav” (“Явь”) [2, 4].

As a rule, a frequency modulation of the microwave signals is implemented according to the scheme shown in Fig. 1*b*.

The block diagram shows:

- 1 – varactor converter;
- 2 – mm-range generator;
- 3 – output attenuator;
- 4 – output antenna;
- 5 – control unit.

The control voltage is formed as a saw-like (triangular) or stepped voltage, which is applied to the varactors of the high-frequency generator. The formation of such voltage in computerized devices is carried out using digital-to-analog converters and can have different shapes and different frequency modulation indices.

With the help of the control unit, a low-frequency signal as a saw-like or triangular voltage is generated and is supplied to the varactor converter. Under the influence of the modulation signal, the varactor capacitance changes, and, therefore, the frequency of the EHF generator (2). The limits of the frequency change are determined by the characteristics of the varactor converter.

The most modern devices for millimeter therapy include the microprocessor device “ARIA-SC” (Ukraine) and “AMT-Kovert-04” (“АМТ-Коверт-04”) (Russia), which allow to provide different modulation modes and to receive complex modulated signals as the output.

The capabilities of these devices in terms of automation, service functions, and modulation modes significantly outpaces the requests of doctors in terms of their objective usage and evaluation of the proposed modes in the treatment process. Therefore, dozens of different modulation combination modes still require approbation and field testing with specific patients and diseases in hospitals and dispensaries with the development of recommendations for their practical usage in new technologies of the practical medicine.

A device for the millimeter therapy with modulation of output monochromatic signals

The device, provided in Fig 2, is developed by the team of authors [4] to provide technologies for low-intensity millimeter therapy.

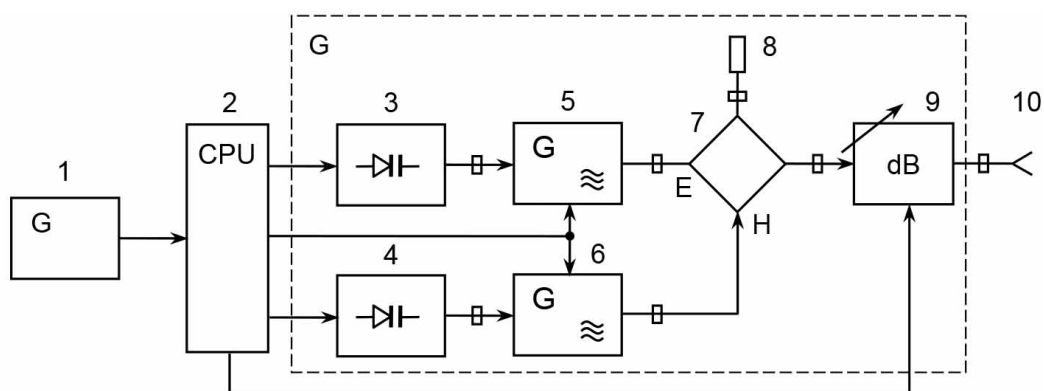

Fig. 2. Simplified block scheme of the automated generator of monochromatic signals "ARIA-SC"

This is achieved by allocating a waveguide system and a double waveguide adapter 7 of a low-intensity voltage of the second harmonic signal of the first or second generator

$$u_1(t) = U_1 \cos 2\omega t = k_1 k_2 U_1 \cos 4\pi(f_1 \div f_2)t, \quad (1)$$

or

$$u_2(t) = U_2 \cos 2\omega t = k_1 k_2 U_2 \cos 4\pi(f_2 \div f_3)t, \quad (2)$$

where: k_1 is a coefficient of signal transmission by the waveguide system and double adapter 7; k_2 is a coefficient of the output attenuator 9 reduction.

Besides that, the double waveguide adapter 7 provides a junction between the generators, by connecting their outputs to the inputs E and H of the adapter. Such construction of the generator block, the usage of the second harmonic, and the block thermostating provide the high stability of an output signal, on both the frequency and the output power. The microprocessor unit 2 through digital-to-analog converters provides the control of the operating modes of generators 5 and 6 and attenuator 9, setting the frequency and the level of the signal output power, type, and parameters of the modulation, session time, etc.

Fig. 3 shows the appearance of the device set "ARIA-SC". The device set includes the power supply unit (on the right), the control unit with digital indicators (in the center) for setting the output frequency,

A simplified block scheme of this device ("ARIA-SC") includes power supply 1, microprocessor control unit 2 (micro ECM), and generator unit G.

The generator unit consists of two generators of microwave monochromatic signals 5 and 6, which operate in the frequency range $(f_1 \div f_2)$ and $(f_2 \div f_3)$. The choice of the operating frequency is provided by the microprocessor unit 2, and the control is carried out by changing the parameters of the varactors 3 and 4. This provides a continuous output operating frequency range of the device.

The peculiarity of the device is that its output range is twice as wide as the frequency ranges of microwave generators.

power, and time of the procedure, and the generator unit placed on a support.

The analyzed possibilities of "ARIA-SC" automated control of initial parameters and modes of modulation expand the scope of the device application in medical practice and increase the efficiency of treatment.



Fig. 3. Automated generator of monochromatic signals "ARIA-SC"

The automated device of monochromatic signals "ARIA-SC" provides high technical parameters and opportunities including:

- operating frequency range of 53-63 GHz, with an installation error of ± 40 MHz;
- frequency readjustment in increments of 10 MHz after 30 or 1 sec;
- automatic frequency readjustment with a period of 0.1 sec in the range of ± 10 MHz and ± 100 MHz, close to the set frequency value;
- automatic frequency readjustment with a period of 5-10 seconds in the range of 53-58 GHz for the generator G1 and in the range 58-63 GHz for the generator G2.

A combined system for millimeter therapy with modulated noise-like low-intensity signal

Another application in millimeter resonance therapy has an impact on bioactive points by continuous electromagnetic radiation of the noise-like spectrum of the mm range.

As an acting factor, it uses the spectrum components of a broadband signal having the nature of white noise with a uniform spectral density in the entire range of radiation frequencies. In this case, the patient's body itself absorbs the oscillation energy of those frequencies that coincide with its own resonant (therapeutic) frequencies. However, the continuity of the emission of a noise-like signal limits its spectrum that reduces the body reflex response.

In microwave resonance therapy (MRT), the patient's selected biologically active points (BAPs) are exposed with both noise signals and pulses of noise-like electromagnetic radiation of non-thermal intensity with a spectrum in the millimeter wavelength range that follow with a low frequency of biorhythms of the patient's body. To increase the effectiveness of this therapy, electromagnetic radiation is used with a spectrum having the nature of flicker noise in the frequency range from the left border of the millimeter region to the right border of its visible region. Amplitude modulation of microwave radiation is carried out by a low-frequency signal in the range from 0,1 Hz to 100 Hz and is affected by modulated radiation with an average value of the noise power spectral density not exceeding 10^{-18} W/Hz \cdot cm².

The choice of a specific modulation frequency and the average spectral density is carried out according to the subjective feelings of the patient, which does not allow optimizing objectively the parameters of electromagnetic radiation and reducing the time of treatment sessions.

We developed RS, which in the process of patient treating provides objective information about his state of health according to the level of his own electromagnetic radiation in the millimeter range [5]. That allows to set the modulation frequency, stimulating an increase in the level of intrinsic electromagnetic radiation and to adjust the level of external radiation depending on the emissivity of the patient.

This circuit algorithm of the RS operation is constructed by receiving the patient's own electromag-

netic radiation of BAPs in pauses between the irradiating pulses using, for example, a broadband directional coupler connected at the output of the irradiating channel. Processing of received and part of the emitted pulses of electromagnetic radiation can be performed in one receiving radiometric channel consisting of an EHF mixer, an intermediate frequency amplifier, a quadratic detector, a synchronous detector and a low-pass filter, which is connected to the output of a broadband directional coupler.

The goal is to obtain the maximum value of the received object's own electromagnetic radiation by changing the frequency of the audio power generator and regulation of the repetition rate of the irradiating pulses.

The audio power generator simultaneously controls its voltage with an amplitude modulator and a synchronous detector. An increase in the intensity of irradiating pulses to the level of each patient's own radiation and determining the exposure time until a steady-state value of the increased intensity of the patient's own electromagnetic radiation is reached increases the effectiveness of the treatment and reduces the time of the procedure.

Fig. 4 presents a functional diagram of a broadband irradiation MRT system, which contains a mm-wave (EHF) noise generator 1, the output of which is connected in series to an adjustable attenuator 2, a valve 3, an amplitude modulator 4, a broadband directional coupler 5 and a broadband antenna 6.

The output of the broadband directional coupler 5 is connected in series to an EHF mixer 7 with an EHF heterodyne of monochromatic oscillations 8, an intermediate frequency amplifier 9, a quadratic detector 10, a low frequency power amplifier 11, a synchronous detector 12, a low-pass filter 13, and an indicator 14. The audio power generator 15 is connected to the control inputs of the amplitude modulator 4 and the synchronous detector 12. The position 16 indicates the patient's body.

The broadband noise signal of the millimeter-wave generator 1 through the adjustable attenuator 2 and the valve 3 is fed to the amplitude modulator 4, which is designed on pin-diodes and operates by the principle of signal reflection from a closed modulator. When the modulator is open, the noise signal through the directional coupler 5 enters the broadband antenna 6 and is emitted towards the patient. The intensity of electromagnetic radiation is pre-set to minimum using an adjustable attenuator 2 (at the level of the patient's minimum possible radiation).

Part of the emitted signal through a broadband directional coupler 5 is fed to the input of the EHF mixer 7, and the signal from the EHF local oscillator 8 comes to its second input.

As a result of the signal mixing, subtractive intermediate frequency oscillations are generated, amplified by the intermediate frequency amplifier 9. The wide passband of amplifier 9 allows the transfer of a

significant part of the spectrum of the emitted signal to an intermediate frequency.

A signal amplified at an intermediate frequency is detected by a quadratic detector 10.

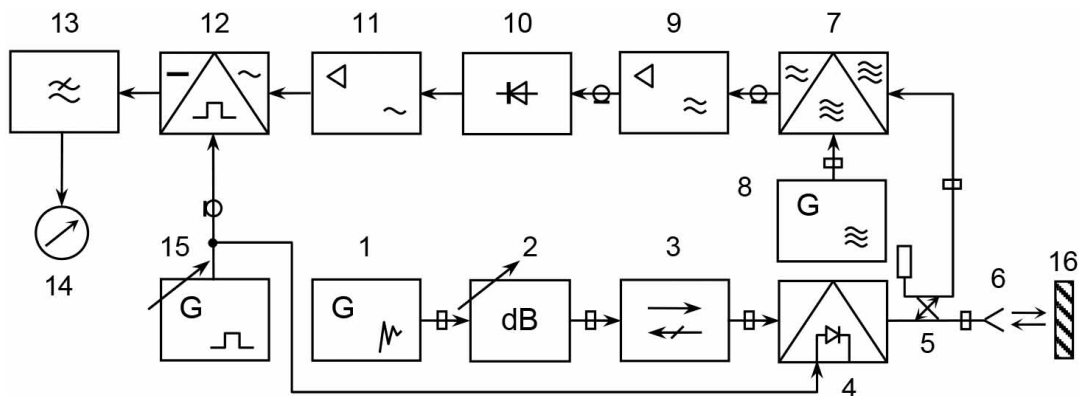

Fig. 4. Block scheme of RS for optimization of the exposure parameters by the patient's own radiation

The patient's own millimeter radiation is received by the broadband antenna 6 and then through the open modulator 4 it enters the valve 3, in which it is absorbed. Received radiation does not enter the directional coupler 5.

The rectangular voltage of the low-frequency generator 15 controls the amplitude modulator 4. When the amplitude modulator 4 is closed, the noise signal of the generator 1 is reflected from the modulator and absorbed in the valve 3. The noise signal received by the broadband antenna 6 from the BAP of the patient is reflected from the closed modulator 4 and through the directional coupler 5 enters the input of the EHF mixer 7.

The dispersion of the noise signal received by the broadband antenna is determined by the expression

$$\bar{U}_1^2 = S_1, \quad (3)$$

where: S_1 – is the sensitivity of the antenna; T_E is the effective temperature of the irradiated BAP on patient's skin.

If the gain coefficient of the directional coupler 5 is designated K_1 , then the dispersion of the input signal of the EHF mixer 7, taking into account its own noise, has the form:

$$\bar{U}_{21}^2 = K_1 \bar{U}_1^2 + \bar{U}_3^2, \quad (4)$$

where \bar{U}_3^2 – is the dispersion of the intrinsic noise of the EHF mixer 7 reduced to its input, taking into account the noise of the heterodyne 8 and amplifier 9.

With the modulator U_1 open, the dispersion of the input signal of the EHF mixer 7 will be:

$$\bar{U}_{22}^2 = K_1 K_2 \bar{U}_0^2 + \bar{U}_3^2, \quad (5)$$

where K_2 – is the gain of the attenuator A1; \bar{U}_0^2 is the dispersion (power) of the noise signal of the generator 1.

Thus, as a result of switching the modulator 4 with a low frequency, electromagnetic radiation pulses impact on the patient being irradiated with a repetition

rate set by the generator 15 and pulse duty cycle that equals 2. At the same time, part of the energy of these pulses also goes to the input of the EHF mixer 7. In the pauses between the irradiating pulses, electromagnetic energy pulses with the same frequency from the patient's BAP with a temperature TE comes up at the input of the EHF mixer 7. So after combining these pulses at the input of the EHF mixer 7, at its output an EHF signal is formed modulated in amplitude with a modulation depth:

$$m = \frac{K_1 (K_2 \bar{U}_0^2 - \bar{U}_1^2)}{K_1 (K_2 \bar{U}_0^2 + \bar{U}_1^2) + 2\bar{U}_3^2}. \quad (6)$$

Given that the power of the intrinsic noise of the EHF mixer is much higher than the power of millimeter radiation during resonant therapy ($\bar{U}_3^2 \gg K\bar{U}_0^2$), we obtain:

$$m = \frac{K_1 (K_2 \bar{U}_0^2 - \bar{U}_1^2)}{2\bar{U}_3^2} \ll 1. \quad (7)$$

Pulses of the modulated signal transferred to the intermediate frequency are alternately detected by the quadratic detector 10, forming video pulses with amplitudes at the output:

$$U_4 = S_1 K_3 S_2 (K_1 \bar{U}_1^2 + \bar{U}_3^2), \quad (8)$$

$$U_5 = S_1 K_3 S_2 (K_1 K_2 \bar{U}_0^2 + \bar{U}_3^2), \quad (9)$$

where S_1 – is the steepness of the conversion of the mixer 7; K_3 – is the gain of the amplifier 9 of intermediate frequency; S_2 – is the steepness of the transformation of the quadratic detector 10.

The low frequency power amplifier 11 amplifies the variable component of the sequence of video pulses with amplitude:

$$U_6 = K_4 \frac{U_4 - U_5}{2} = K_1 S_1 K_3 S_2 K_4 \frac{\bar{U}_1^2 - K_2 \bar{U}_0^2}{2}, \quad (10)$$

where, K_4 – is the gain of the low frequency power amplifier 11.

The amplified alternating voltage is rectified by a synchronous detector 12, which is controlled by the low-frequency voltage of the generator 15. The rectified voltage is smoothed by the low-pass filter 13 and fixed by the indicator 14. It is possible to provide the maximum indexes on indicator 14 by changing the pulse repetition rate of electromagnetic energy pulses using the generator 15. That means that when $K_2 \bar{U}_0^2 = \text{const}$ the difference in the intensities of the radiated and received energy increases:

$$\Delta U = U_1^2 - K_2 U_0^2 > 0. \quad (11)$$

That indicates an increase in the intensity of the patient's own radiation. It means the activation of energy resources of the irradiated biological object.

Then, by adjusting the gain of the attenuator 2, the 14 indicator reads comes to zero when

$$K_2 \bar{U}_0^2 = \bar{U}_1^2. \quad (12)$$

From here, the gain coefficient of the attenuator 2 is

$$K_2 = \frac{\bar{U}_1^2}{\bar{U}_0^2}. \quad (13)$$

Conditions (12) and (13) mean that the intensities of the millimeter effect and the intrinsic millimeter radiation of the object are equal, so it allows us to choose the optimal MRT conditions.

We can see from the condition (12) that its implementation is not affected by the instability and inconsistency of the parameters of the units of the measuring pathway of the circuit (K_1, S_1, K_3, S_2, K_4). Thus, using the considered method, we can optimize the repetition rate and intensity of millimeter-wave pulses and thereby increase the effectiveness of treatment and shorten its time.

The sequence of the RS operation is as follows. First, the attenuator 2 provides the maximum attenuation ($K_2 \approx 0$). In this case, the patient is practically not irradiated with anything, and the antenna 6 receives only its own millimeter radiation from the BAP. The modulation depth of the EHF signal (7) is set to maximum, and the power amplifier 11 amplifies a relatively large alternating voltage with amplitude

$$U'_6 = 0,5 K_1 S_1 K_3 S_2 K_4 \bar{U}_1^2. \quad (14)$$

This voltage is rectified by a synchronous detector 12 and is measured by indicator 14.

Then, the attenuation of the attenuator 2 is reduced ($K_2 > 0$), and the process of irradiating the patient with millimeter radiation begins. The radiation intensity increases to obtain a zero reading of the indicator 14. This means a preliminary equalization of the radiated and received electromagnetic energy.

After reaching zero values, the frequency of the generator 15 changes, obtaining the maximum values of the indicator 14, which means an increase in the intensity of the body's own radiation under the influ-

ence of stimulating pulsed radiation. Then, the irradiation intensity of the attenuator 2 is increased again until the indicator 14 reaches zero, i.e. until the equality of the irradiated and increased received energies is established, and so on.

The frequency tuning of the generator 15 and attenuator 2 is repeated 3-4 times during the MRT process to obtain optimal millimeter-wave radiation parameters. The cessation of changes in the indicator 14 indicates the object saturation with electromagnetic energy, after which the MRT session ends. The procedure repeats in the next treatment session.

The treatment process is considered complete when a stable and sufficiently high level of intrinsic millimeter radiation (approximately 10-12 W/cm²) is observed during regular MRI sessions [3]

The considered RS can be used for human and animal diagnostics by the level of their own electromagnetic radiation with the noise generator 1 turned off. Studies have shown that the spectral density of the intrinsic radiation of a healthy person in the millimeter range is $10^{-22} \dots 10^{-21}$ W/Hz·cm² [6, 7]. A decrease in the level of intrinsic radiation of less than 10^{-22} W/Hz·cm² may indicate serious disturbances in the human body.

The use of highly sensitive radar-type equipment (presented above) made it possible to study the absorption capacity of a person in the mm-wave range from an external source. The results of experimental studies described in [8] showed that at some frequencies, an increased absorption of the power of the irradiating signal is recorded. These frequencies are referred to as “absorption resonances”. Experimentally, resonant absorption was observed at individual frequencies in the 53-37 GHz range, as well as at a higher frequency 53-78 GHz. The dynamic range of absorption recorded in the experiment was $K_{\max} = 10 \lg(P_{\max}/P_{\min}) \approx 20$ dB (100 times). It should also be noted that, in comparison with a person's own radiation level, there is a “non-resonant” absorption threshold of 4-6 dB, which is maintained throughout the entire mm-frequency range.

At the same time, many medical devices use modulation of both monochromatic and noise-like low-intensity mm-band signals. To study the effect of amplitude modulation of such signals on the absorption capacity of the human skin surface, a highly sensitive mm-range radiometric system and a generator of low-intensity noise-like signals were used. The functional diagram of the installation is shown in Fig. 5.

The output signal of the noise generator G through the absorbing attenuator W2, the circulator W3 entered the input of the antenna A and through it irradiated the human skin surface S. The reflected signal, which passed through the same circulator and the precision attenuator W1, was recorded by the RS radiometric system. The substitution method was used to determine the absorption level. In this case, the excess intensity of the received signal was recorded

above the level of thermal noise of the measuring equipment.

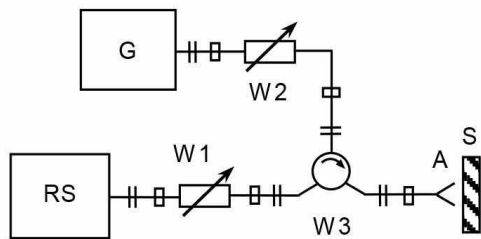

Fig. 5. Functional diagram of the measurement of the absorption coefficient for low power levels of the mm-range

The intensity of the irradiated signal was regulated in the range from $5 \cdot 10^{-22}$ to $3 \cdot 10^{-22}$ W/Hz \cdot cm² above the level of thermal noise. The amplitude modulation frequency of the noise generator G was adjusted in the range from 1 Hz to 100 kHz. As shown by the results of measurements, the power reflection coefficient Γ_p in the indicated range of intensities of the irradiating signal is 0.17...0.18, i.e. at weak signals, its intensity and frequency of amplitude modulation have practically no effect on the absorption properties of the skin surface.

Conclusions

1. Comparison of the power levels, that are emitted and absorbed by human skin, shows that the human body is essentially in the mode of “informational” perception of external irradiation, reacts to weak microwave signals that are equal or by 1-2 orders higher than its radiation.

2. The use of the considered devices with amplitude or frequency modulation of output signals in clinical practice allows use of low-intensity signal levels and expands the list of diseases, the treatment of which is associated with the use of microwave therapy.

3. Besides, this reduces the treatment time by optimizing the exposure parameters and their relationship with the level of intrinsic radiation of a biological object (human, animal, or plant).

4. The conducted studies reveal the process of interaction of low-intensity microwave radiation with the human body and can be used in technologies of millimeter therapy.

УДК 621.317: 621.37:612.84

¹⁾О. Яненко, ¹⁾С. Перегудов, ¹⁾К. Шевченко, ²⁾В. Кичак

¹⁾ Національний технічний університет України «Київський політехнічний інститут імені Ігоря Сікорського», Київ, Україна

²⁾ Вінницький національний технічний університет, Вінниця, Україна

МОДУЛЯЦІЯ НИЗЬКОІНТЕНСИВНИХ СИГНАЛІВ В МІКРОХВИЛЬОВІЙ АПАРАТУРІ ДЛЯ ФІЗІОТЕРАПІЇ

References

- [1] W.R Adey, “Frequency and Power Windowing in Tissue Interactions with Weak Electromagnetic Fields”, *Proc. of IEEE*, vol. 68, no. 1, pp. 140-147, 1980.
- [2] С. П. Ситько, Ю. А. Скрипник, и А. Ф. Яненко, Аппаратурное обеспечение современных технологий квантовой медицины. Киев, Украина: ФАДА ЛТД, 1999.
- [3] O. P. Yanenko, S. M. Peregudov, I. V. Fedotova, O. D. Golovchanska, “Equipment and technologies of low intensity millimeter therapy”, *Visnyk NTUU “KPI” Seriya: Radiotekhnika. Radioaparotobuduvannya*, no. 59, pp. 103-110, 2014. doi: 10.20535/RADAR.2014.59.103-110
- [4] V. Y. Stepanov, A. F. Ponomarenko, V. P. Palamarchuk, S. P. Sitko, O. P. Yanenko, *Device for microwave therapy*. Patent UA № 32614, MKI A61N5/02, bul. № 3 (15.08.2000), <https://base.uipv.org/searchINV/search.php?action=viewdetails&IdClaim=20461>
- [5] S. P. Sitko, Yu. O. Skrypnyk, O. P. Yanenko, *Method and device for resonance therapy employing the waves of millimeter range*. Patent UA № 53664, MKI A61N5/02, bul. № 2 (17.02.2003), <https://base.uipv.org/searchINV/search.php?action=viewdetails&IdClaim=96>
- [6] Ю. А. Скрипник, А. Ф. Яненко, Манойлов В.Ф. и др. Микроволновая радиометрия физических и биологических объектов. Житомир, Украина: Волинь, 2003.
- [7] O. Yanenko, “Low-intensive microwave signals in biology and medicine”, *Journal of Human Physiology*, vol. 1, no. 1, pp. 29-41, 2019. Doi: 10.30564/jhp.v1i1.1453
- [8] Yu. A. Skrypnyk, A. F. Yanenko, “Razvitiye predstavleniy ob izluchayushchey i pogloshchayushchey sposobnosti bioobyektov v diapazone sverkhvysokikh chastot [Development of ideas about the emitting and absorbing capacity of biological objects in the ultrahigh frequency range]”, *Measuring and computing devices in technological processes*, no. 2, pp. 135-138, 1999.

У статті описані особливості амплітудно-частотної модуляції вихідних сигналів генераторів міліметрового діапазону для мікрохвильової терапії. Здійснено огляд появи можливих біологічних та медичних ефектів за допомогою модульованих сигналів. Використання високочутливого обладнання радіолокаційного типу дозволило вивчити здатність людини до поглинання в діапазоні мм-хвиль від зовнішнього джерела. Описано результати експериментальних досліджень авторів, це показало, що на деяких частотах реєструється підвищене поглинання потужності опромінюючого сигналу. Ці частоти називаються "резонансами поглинання". Представлено оригінальні схеми монохроматичних та шумових генераторів сигналів, розроблені авторами, та описано принцип їх роботи.

У статті показано можливість формування сигналів низької інтенсивності та забезпечення роботи діапазону генератора з використанням другої гармоніки монохроматичного сигналу та селективні властивості КВЧ-вузлів. Розкрито технічні параметри та характеристики розроблених пристроїв. Області застосування розроблених пристроїв у практичній медицині окреслені. За допомогою блоку управління генерується низькочастотний сигнал у вигляді пилкоподібної або трикутної напруги, який подається на перетворювач варактора. Під впливом сигналу модуляції змінюється ємність варактора і, отже, частота КВЧ генератора. Описано роботу комбінованої системи вимірювання випромінювання з модульованим шумоподібним вихідним спектром та відгуками пацієнта. У статті продемонстровано широкі практичні можливості використання мікропроцесорної технології для автоматизації та управління процесом вибору режиму роботи, для формування та зміни параметрів модуляції мікрохвильового сигналу.

Проведені дослідження розкривають процес взаємодії низькоінтенсивного мікрохвильового випромінювання з тілом людини і можуть бути використані в технологіях міліметрової терапії. У статті описані сервісні функції розробленого обладнання, які сприяють його більш ефективному використанню в технологіях мікрохвильової терапії

Ключові слова: міліметрова терапія; сигнали низької інтенсивності; мікрохвильові генератори; модуляція сигналу.

¹⁾А. Яненко, ¹⁾С. Перегудов, ¹⁾К. Шевченко, ²⁾В. Кичак

¹⁾Национальный технический университет Украины «Киевский политехнический институт имени Игоря Сикорского», Киев, Украина

²⁾Винницкий национальный технический университет, Винница, Украина

МОДУЛЯЦИЯ НИЗКОИНТЕНСИВНЫХ СИГНАЛОВ В МИКРОВОЛНОВОЙ АПАРАТУРЕ ДЛЯ ФИЗИОТЕРАПИИ

В статье описаны особенности амплитудной и частотной модуляции выходных сигналов генераторов миллиметрового диапазона для микроволновой терапии. Проведен анализ появления возможных биологических и медицинских эффектов, возникающих под действием модулированных СВЧ сигналов. Представлены оригинальные схемы монохроматических и шумовых генераторов сигналов, разработанные авторами, и описан принцип их работы. В статье показана возможность формирования сигналов низкой интенсивности и обеспечения работы диапазона генератора с использованием второй гармоника монохроматического сигнала и рассмотрены селективные свойства КВЧ-узлов. Так, с помощью блока управления генерируется низкочастотный сигнал в виде пилообразного или треугольного напряжения, который подается на преобразователь варактора. Под влиянием сигнала модуляции меняется емкость варактора и, следовательно, частота КВЧ генератора.

Рассмотрена работа комбинированной системы измерения излучения с модулированным выходным шумоподобным спектром и реакция пациента на такие сигналы. Представлены технические параметры и характеристики разработанных устройств и определены сферы их применения в медицине.

В статье продемонстрировано широкие практические возможности использования микропроцессорной техники для автоматизации и управления процессом выбора режима работы и изменения параметров модуляции микроволнового сигнала. Описаны сервисные функции разработанного оборудования, способствующие более эффективному его использованию в технологиях микроволновой терапии.

Ключевые слова: миллиметровая терапия; сигналы низкой интенсивности; микроволновые генераторы; модуляция сигнала.

Надійшла до редакції
13 лютого 2021 року

Рецензовано
3 березня 2021 року