

Abstract

A structural and functional organization of scheme to control the amount of oxygen used in the medical facility. Implementation of the proposed system will optimize the use of oxygen and provide its accurate records.

Keywords: medical institution; oxygen; calculation of gas; microprocessor system.

40 15 1,0 1,2 0,01³ 20³ (

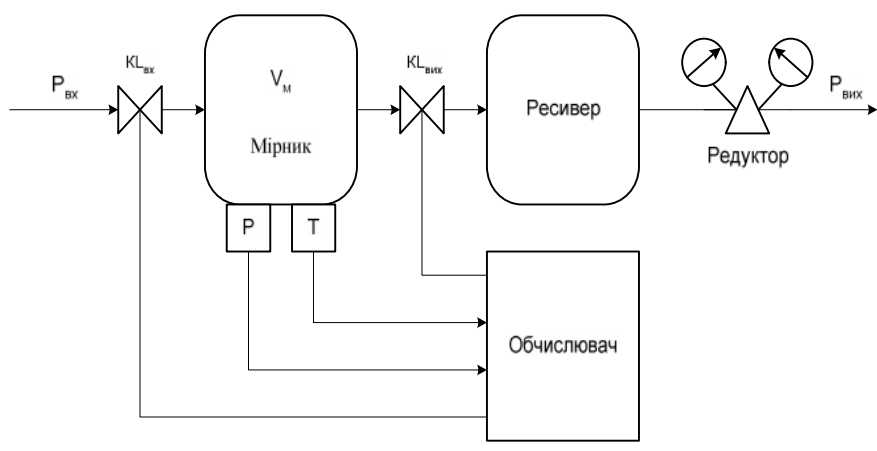

. 1.

