

STUDY OF THE ELECTROMAGNETIC IMPACT OF THE OVERHEAD TRANSMISSION LINES OF 330 KV ON ECOLOGICAL SYSTEMS

Veronika Cherkashina¹, Svitlana Litvinchuk², Vladyslav Lesko³, Svetlana Kravets⁴, Volodymyr Netrebskiy³, Olena Sikorska³, Orken Mamyrbayev⁵, Baglan Imanbek⁵

¹Kharkiv National Technical University "Kharkiv Polytechnic Institute", Kharkiv, Ukraine, ²Mykolayiv National Agrarian University, Mykolayiv, Ukraine

³Vinnitsia National Technical University, Vinnitsia, Ukraine, ⁴Vinnitsia National Agrarian University, Vinnitsia, Ukraine, ⁵Al Farabi Kazakh National University, Institute of Information and Computer Technologies, Almaty, Kazakhstan

Abstract. The analysis of factors and approaches to the conditioning of the electromagnetic impact of 330 kV overhead transmission lines on ecological systems has been carried out. The analysis performed enabled to reveal that the world experience, recording the introduction of the transmission lines of the carrying capacity and reduced environmental impact, including the compact and controlled self-compensating lines, is expedient to take into consideration in the process of the object design, as compared with the transmission line of the conventional construction, operated in Ukraine. The technique of electromagnetic field of the 330 kV overhead transmission lines calculation is improved for the ecological systems and to clarify the width of the sanitary protection zone. Unlike other technique, the given one takes into account the line clearance and the sag of, also this technique is universal as it enables to calculate and analyze the variation of the electromagnetic field of the overhead transmission lines of different construction not only on the line route, but also at a distance from it.

Keywords: overhead transmission line, construction, electromagnetic field, ecologic system, sanitary protection zone

BADANIE ODDZIAŁYWANIA ELEKTROMAGNETYCZNEGO NAWIETRZNYCH LINII PRZESYŁOWYCH 330 KV NA SYSTEMY EKOLOGICZNE

Streszczenie. Przeprowadzono analizę czynników i podejść do uwarunkowań oddziaływania elektromagnetycznego napowietrznych linii przesyłowych 330 kV na systemy ekologiczne. Analiza pozwoliła stwierdzić, że doświadczenia światowe, odnotowujące wprowadzenie linii przesyłowych o większej nośności i mniejszym oddziaływaniu na środowisko, w tym linii kompaktowych i sterowanych samokompensujących, są celowe do uwzględnienia w procesie projektowania obiektu, w porównaniu z linią przesyłową o konstrukcji konwencjonalnej, eksploatowaną na Ukrainie. Technika obliczania pola elektromagnetycznego napowietrznych linii przesyłowych 330 kV została udoskonalona pod kątem systemów ekologicznych oraz w celu uściślenia szerokości strefy ochrony sanitarnej. W odróżnieniu od innych technik, ta uwzględnia przeswit i zwis linii, a także jest uniwersalna, gdyż umożliwia obliczanie i analizę zmienności pola elektromagnetycznego napowietrznych linii przesyłowych o różnej konstrukcji nie tylko na trasie linii, ale także w pewnej odległości od niej.

Słowa kluczowe: napowietrzna linia przesyłowa, budowa, pole elektromagnetyczne, system ekologiczny, strefa ochrony sanitarnej

Introduction

Rates of commissioning of objects of electric power systems of Ukraine reached their peak values in the 60-70s of the last century. Nowadays with the same rate electric engineering objects overstep their 50-year limit. In the process of operation, the conditions of electric power systems changed, these changes are characterized by an increase of the transmitted power density both in normal modes and in emergency modes, necessity of the compact realization of the electric energy objects due to considerable rise in the value land, increased requirements concerning the reliability, controllability and automation, as well as a more rigid ecological policy.

Increase of the compactness and ecological safety of the electric energy objects in the requirement of the present day, the necessity to apply new approaches for the assessment of the priority decisions.

Right of ways under overhead transmission lines with the account of their considerable length can reach considerable size. For electrical – of 35 – 750 kV the area of the disposed territories as a result of the overhead transmission lines passage is 21,179.55 km [5].

This problem is extremely actual for the territories with the developing infrastructure, where the value of land increases exponentially. To reduce the disposal of territory under the overhead transmission lines and decrease the ecological impact so-called non-conventional line find wide application along with the overhead transmission lines of the conventional construction: compact overhead lines (COL); controllable self-compensated overhead lines (CSCOL); overhead lines with circuits of different voltage classes (combined overhead lines); overhead lines with insulated conductors (OLIC) [1].

1. Aim of the paper

Analyze factors and approaches, regulating electromagnetic impact of the overhead lines on the ecological systems. Improve the technique of the electromagnetic field strength – fir the determination of their impact on ecological systems and to – the width of the sanitary-protection zone, depending on the construction of the lines.

2. Main materials of the research

Analysis of factors and approaches to the normalization of the electromagnetic impact of the overhead transmission lines on the ecological systems. Relatively the impact of the AC overhead transmission lines on the ecological systems, the criteria of the harmful impact assessment are established, principles of regulation and protection measures. Numerous international organizations, such as the World Health Organization (WHO), the International Electrotechnical Commission (IEC), the European Committee for Electrotechnical Standardization (CENELEC), the Commission of the European Union (CEU), National Commissions, deal with problems of the normalization of electromagnetic field influencing the staff and population.

Main factor of the overhead transmission lines of 330 kV, determining the width of the sanitary-protection zone and influencing the ecological systems in electromagnetic field (EMF), characterized by the electromagnetic field strength. All the manifestations of the negative impact on the ecological systems may be divided into groups [1, 7, 10, 14]:

1. Impact of the electromagnetic field on the living organisms.
2. Impact of the harmonic noise on communication lines.
3. Interaction of overhead lines with engineering communications.
4. Acoustic impact of overhead lines on the environment.
5. Interaction of overhead lines with the natural landscape.

Normalization of the factors of AC overhead lines impact, their coordination with the results of numerous and sometimes contradictory medical research is extremely complex task, especially taking into simultaneous and interconnected impact of several factors. The importance of the consideration of EMF impact on the ecological systems all over the world is caused by the necessity of the objective assessment of the real danger for human health. Such an approach is determined also by the economic reasons as the observance of the sanitary norms and provision of the normalized width of the sanitary-protection zone for overhead lines (OHL) is connected with the considerable expenditures.

By its frequency characteristic electromagnetic field (EMF) of the overhead lines (OHL) is referred to the low-frequency range. As a rule, the staff maintaining the overhead installations is exposed by the short-term impact of the strong EMF. The population main remain in the zone of the weak fields of the industrial frequency, for instance, living near an overhead lines.

Nowadays the attention of the biophysicists and medical scientists is drawn not only to the study of the effects of short-term impact of the strong fields, but to the determination of the long-term consequences impact of weak low-frequency EMF, up to the super weak ones with the intensity of approximately 0.1 A/m (0.12 μ Tl), comparable with the intensity of low-frequency earth geomagnetic field.

It is known that the intensity of EMF near 330 kV overhead lines and higher may reach the boundary of the individual field susceptibility, when a person by indirect indication (hair stirring, pin sensation between the body and clothing) can determine the field. Approximately 5% of people feel the presence of EMF, starting from the intensity of 7 kV/m, and 60% do not feel the field with the intensity of up to 20 kV/m. Intensity of the EMF of 5 kV/m, acceptable by the standard, determined by biological impact be acceptable, taking into account the possible unfavorable. Action of the electrical charges in the process of the human contact with surrounding objects. By the results of the research the intensity of the EMF, when 80% of people do not feel pain sensations at the discharges, equals 5.2 kV/m [6, 8, 10, 11].

Negative impact of EMF of the industrial frequency was disclosed as a result of the examination of the staff, servicing energy objects, experiments on the laboratory animals and study volunteers, carried out since the 60s of the last century, further in the studies of numerous researchers. International recognition of the biological activity of EMF required the residence time regulation. As a result, in the USSR state standard GOST 12.1.002-84 was elaborated and approved. For the staff of the unrelated organizations and the local population the following norms were established: 20 kV/m for the in accessions location; 15 kV/m for unpopulated areas. Besides, admissible intensity 0.5 kV/m is normalized this allows the stay of a person in the electrical field for 24 hours a day.

International recommendations are based on the revealing of the negative impact on the organism, manifested directly at the moment or immediately after impact to EMF, and do not take into account possible long-term exposure to the impact of weak EMF [4, 7, 12, 13, 15].

As a result of numerous researches, carried out in recent decades the biological activity of weak low-frequency fields was revealed. This result turned but to be unexpected, because as a rule, the intensity of the bioeffects increases in proportionally the intensity of the acting factor. Swedish, Finnish, American, Canadian, French researchers identified carcinogenic effect up weak EMF.

Simultaneously, there appeared studies, denying these observations. Nowadays, approximately 30% of the studies prove that weak EMF of the industrial frequency can increase

the number of a cancer related disease, 30% of studies claim the opposite and in 40% of cases scientists neither agree nor disagree, considering that epidemiological studies must be well-planned taking into account the variety of the factors of the environment and professional activity [4, 7, 15].

In 1996, World Health Organization (WHO) initiated the International EMF Project. The aim of the given project is to collection, analysis, generalization and coordination of the results of all the investigations, carried out in this field. In 2001 WHO issued information message, recommending to keep to the "precautionary principle" regarding the impact of low-intensity EMF and by all available means limiting the impact of EMF on human. In 1998, the International Committee ICNIRP, one of the participants in the WHO Project, released the document, regulating the permissible levels of EMF for the population.

All developed countries realize their programs to studying the impact of electromagnetic radiation on human and environment. For instance, Austria, Germany, Czech Republic, Australia, Spain, Italy and other counties, follow the recommendations suggested by ICNIRP, recording the regulation of EMF [4, 7, 12–15].

In general case, the parameter which determines the degree of EMF impact on a human is the density of the current induced in the body. In greater part of the International Standards non-dangerous for the organism density of current 10 mA/m² is considered as the initial value for establishing of the admissible levels of EMF parameters. Equivalent intensity of EMF, corresponding to this density, can then be decreased, applying the factor of margin for the conditions of the industrial impact and for the population. Reference level, obtained in such a way is fixed as normalized levels [7].

Such an approach to the normalization of the factors is often used abroad. In Ukraine and in some other countries, as the parameter, determining admissible levels of field intensity, maximum admissible current, flowing across the human body in case of the contact in the zone of EMF impact with the isolated machine or other large insulated object is considered. Environmental legislation functioning in Ukraine, defines principles, rules and ecological system. So-called sanitary regulation, regulating maximum permissible levels of the electric field intensity, formed by A.C. electric transmission installation of the industrial frequency [14].

Staying of the people, not electrical engineering staff, in the zone of EMF impact nowadays in Ukraine is regulated by the intensity of EMF, which is on the territory of the residential area –1 kV/m. But it should be noted that such level of EMF intensity is on the boundary of sanitary-protection zone of the overhead lines, limits of which on the both sides from the projection of the outer conductors on the earth are: 20 m – for 330 kV overhead lines and 40 m – for 750 kV overhead lines and for the overhead lines bellow 330 kV sanitary-protection zones are not established [10, 14].

As the organization of the boundaries of sanitary protection zone of the overhead lines is connected not only with considerable economic expenses, but also with the exclusion of land. This circumstance caused the necessity to perform the additional calculations of EMF impact factor in the points, remote from the conductors of the line and indicate the boundaries of the sanitary-protection zone. As in Ukraine conventional overhead lines are used, then all normative documents correspond to certain construction realization. Taking into consideration the world experience, regarding the introduction of the transmission lines of enhanced carrying capacity and decreased ecological impact, to which compact and controlled self-compensating overhead lines, are referred to, it is expedient to consider them and compare with the conventional overhead lines.

3. Method

Formation of the technique of EMF intensity calculation for the determination of 330 kV overhead lines impact on the ecological systems and adjustment of the width of sanitary-protection zone, depending on the construction of the lines.

From the point of view of determination of EMF impact on the ecological systems, that is determined by the value of EMF intensity, the problem is reduced to finding the potential of the conducting body placed in the field of the overhead line (Fig. 1).

For the determination the EMF intensity of 330 kV overhead lines of various construction (Fig. 1), the following initial data are used: U – the voltage of the overhead lines (OHL), kV; H – dimensions of the conductors of overhead lines, m; H_w – dimensions of the steel wires of the overhead lines, m; S_w – distance from the axis of the overhead line to the steel wire, m; S_z – distance between phase circuits, m; S_f – distance between phases, m; a – the distance between the conductors in a phase, m; n – the number of conductors in a phase; r_{cond} – radius of the overhead line wire, m; r_w – radius of the steel wire, m; L – horizontal distance from the axis of the outer conductor of the overhead line to the calculated point, m (towards the middle phase with the sing “-”); h – coordinates of the preset point, m; Δh – differentiation step, m.

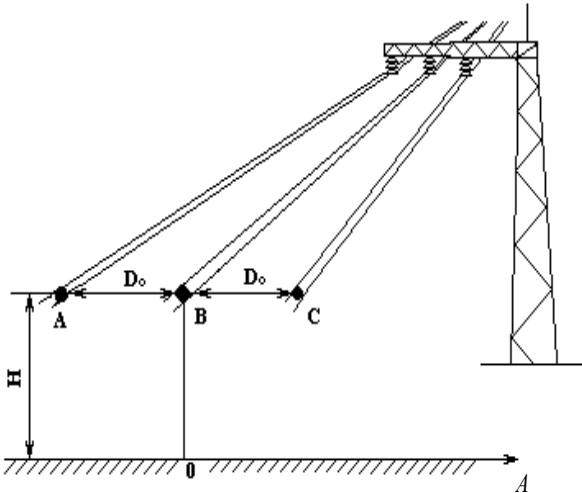

Fig. 1. Schematic representation of the overhead line for the determination of EMF intensity

Calculation of the field parameters is possible to perform using Maxwell equation for the system "conductors – steel wires – earth" [2, 3, 9]:

$$U_{ij} = \sum_{n=1}^n \alpha_{ij} \cdot q_{ij} \quad (1)$$

where U – phase voltage of the overhead line conductors; α_{ij} – are potential coefficients; q_{ij} – are charges of conductors per unit length.

Potential coefficients α_{ij} are determined from the following relations:

Proper potential coefficients $i = j$

$$\alpha_{ii} = \frac{1}{2\pi\epsilon} \ln \frac{H_{ii}}{r_{ii}} \quad (2)$$

where H_{ii} – is the distance between the i^{th} conductor and its mirror reflection; r_{ii} – is equivalent radius of the conduction or steel wire.

Mutual potential coefficients $i \neq j$

$$\alpha_{ij} = \frac{1}{2\pi\epsilon} \ln \frac{H_{ij}}{r_{ij}} \quad (3)$$

where H_{ij} – is the distance between i^{th} conductor and mirror reflection of the j^{th} conductor; r_{ij} – is the distance between i^{th} and j^{th} conductors.

Using the system of equations (1) the potential coefficients of the impact object α_{jA} are identified

$$\alpha_{jA} = \frac{1}{2\pi\epsilon} \ln \frac{H_{jA}}{r_{ji}} + L \quad (4)$$

where H_{jA} – is the distance between the j^{th} conductor and object; r_{ji} – is the distance between i^{th} and j^{th} conductors; L – is the distance to the object.

Using the second group of Maxwell equations for the determination of the charges on the conductor's capacitive coefficients β are formed:

$$q_{ij} = \sum_{n=1}^n \beta_{ij} \cdot U_{ij} \quad (5)$$

However, it should be noted that the given technique does not require the calculation of the charge on the conductors and the system of equations (4) is used only for the formation of the capacitance coefficients β , which are determined by the formula:

$$\beta_{ij} = (-1)^{i+j} \Delta_{ij} / \Delta \quad (6)$$

where Δ – is the matrix determinant, composed of the coefficients α of the Maxwell equations system (1); Δ_{ij} – is the algebraic complement of the i^{th} and j^{th} elements.

In the process of improvement of the given model the symmetry of the three-phase system of voltages $\dot{U}_1, \dot{U}_2, \dot{U}_3$ was taken into account:

$$\begin{aligned} \dot{U}_1 &= U \\ \dot{U}_2 &= U \cdot a \\ \dot{U}_3 &= U \cdot a^2 \end{aligned} \quad (7)$$

where a and a^2 are complex operators of voltage vector rotation, $a = -0.5 + j0.86$; $a^2 = -0.5 - j0.86$

Potential \dot{U}_A in the present point is determined using (1 – 7):

$$\begin{aligned} \dot{U}_A &= U \sum [\beta_{ij} - 0.5(\beta_{ij} + \beta_{ij}) \alpha_{jA}] + \\ &+ U \sum j0.86 [(\beta_{ij} - \beta_{ij}) \alpha_{jA}] \end{aligned} \quad (8)$$

Having denoted the active and reactive parts of \dot{U}_A by \dot{U}_{Aa} and \dot{U}_{Ap} correspondingly for the module \dot{U}_A we will write down the equation:

$$U_A = \sqrt{U_{Aa}^2 + U_{Ap}^2} \quad (9)$$

While determining the field strength at point A, we will change its vertical component. Having determined the potential at point U_A in point A at height h and \dot{U}_A in the point A' at the $h - \Delta h$ the field strength is determined by expression:

$$E_A = \frac{U_A - U_{A'}}{\Delta h} \quad (10)$$

The obtained value E_A corresponds to the vertical component of the average strength of the electric field in the region of the human head of a person of 1.8 m of height.

4. Results and discussion

Improved technique of calculation unlike other techniques, takes into account the dimension of the line and the sag of the conductor as well it is universal because it enables to calculate and analyze the change of EMF of 330 kV overhead lines of different constructions.

Application of modern technical facilities enables to solve the given task with extreme accuracy. The developed technique was used to compose the block-diagram for automatic calculation of the zone of electromagnetic impact of 330 kV overhead lines on the ecological systems (Fig. 2).

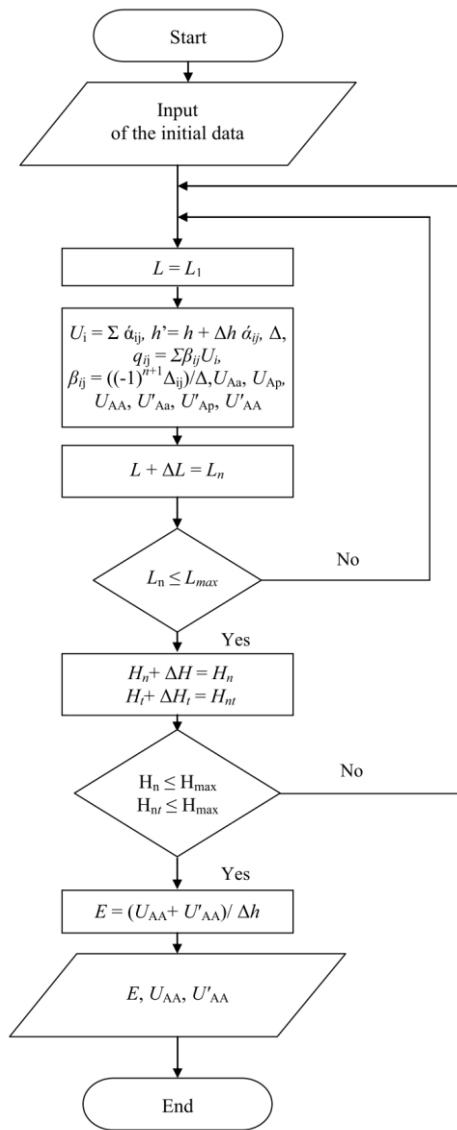

Fig. 2. Block-diagram for automated calculation of the zone of electromagnetic impact of the overhead transmission lines on the ecological systems

Modification of the EMF strength of the overhead lines of 330 kV depends on the dimension and construction of the lines, this is proved by the results of the calculations, performed according to the improved technique (1–10), using block-diagram (Fig. 2) by means of the programming platform the PowerCalc (Copyright Inprise Corporation) and presented in tables 1–3, and figure 3–5.

Fig. 6 presents the generalized graphical representation of the span of the 330 kV overhead transmission line.

Proceeding from the above-mentioned, it follows that the improvement of the construction of 330 kV overhead transmission lines not only increases their carrying capacity, but also limits the strength of EMF near the overhead transmission line, that leads to the decrease of the eliminated areas for overhead transmission lines. Thus, in the process of overhead transmission lines design, routes of which pass near the residential areas or other places where people remain for a long time (play grounds, gardens) it is expedient to include in the pre-project assessment of the variants the analysis of electromagnetic situation near the route of the overhead transmission line, in particular, consider the strength value of EMF not only on the route of the line, but also at a distance of more than 20 m from the projection of the outer conductor, because with the distance from the overhead transmission line, the strength decreases slower, than at small distances, that is why, the given fact requires more accurate calculation [16, 17].

Table 1. Modification of the EMF strength for 330 kV overhead transmission lines of the conventional construction

Dimension H, m	Distance, m	E, kV/m	Distance, m	E, kV/m	Distance, m	E, kV/m
10	20	0.997	20	0.997	28	0.466
12	20	1.21	23	0.922	32	0.445
14	20	1.41	25	0.936	34	0.486
16	20	1.58	27	0.941	36	0.493
20	20	1.78	30	0.976	44	0.462
24	20	1.84	33	0.962	48	0.485
26	20	1.83	34	0.965	50	0.489

Table 2. Modification of the EMF strength compact for 330 kV overhead transmission lines

Dimension H, m	Distance, m	E, kV/m	Distance, m	E, kV/m	Distance, m	E, kV/m
10	20	1.13	22	0.938	30	0.468
12	20	1.34	22	0.938	33	0.467
14	20	1.51	26	0.926	35	0.491
16	20	1.65	27	0.982	38	0.482
20	20	1.81	30	0.983	43	0.483
24	20	1.83	32	0.996	47	0.472
26	20	1.81	33	0.988	49	0.491

Table 3. Modification of EMF strength value for the controlled self-compensating 330 kV overhead transmission lines

Dimension H, m	Distance, m	E, kV/m	Distance, m	E, kV/m	Distance, m	E, kV/m
10	20	0.549	16	0.846	22	0.450
12	20	0.644	16	0.957	24	0.494
14	20	0.725	18	0.864	26	0.445
16	20	0.892	18	0.927	28	0.439
20	20	0.868	18	0.984	30	0.471
26	20	0.870	18	0.952	32	0.496

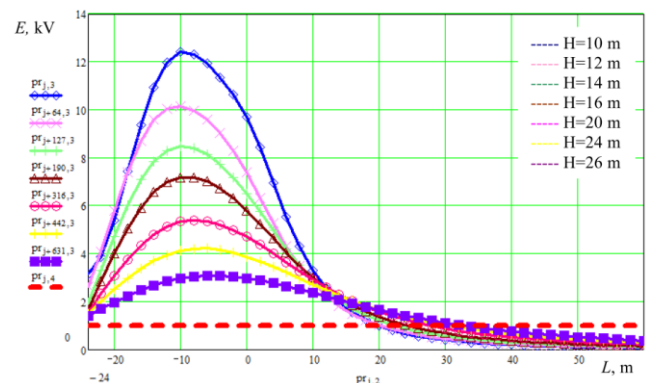

Fig. 3. Dependence of EMF strength modification on the dimension of 330 kV overhead transmission line of the conventional construction

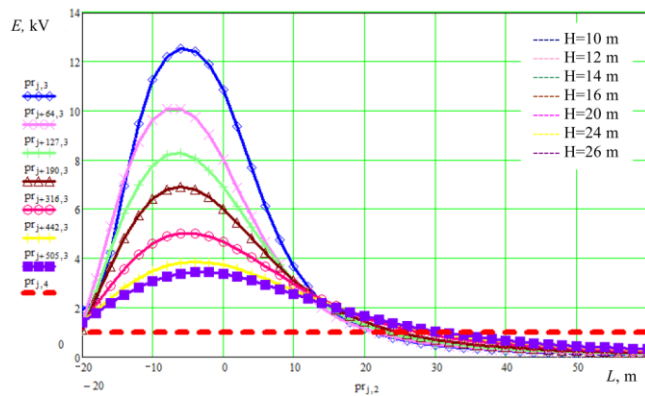

Fig. 4. Dependence of EMF strength modification of the dimension of compact 330 kV overhead transmission line

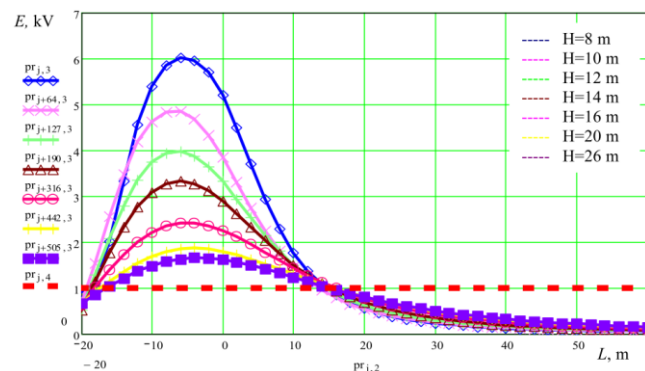

Fig. 5. Dependence of EMF strength modification on the dimension of CSOTL 330 kV

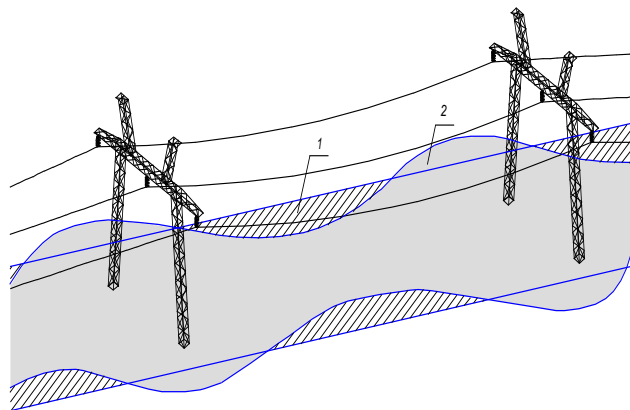

Fig. 6. Generalized graphical presentation of the span of 330 kV overhead transmission line: 1 – territory, normalized for the overhead transmission line, with the account of sanitary-protection zone; 2 – the territory, calculated for the overhead transmission line, with the account of sanitary protection-zone

For the realization of these tasks the following engineering solutions can be used:

- decrease of the interphase distances at a result of carrying out measures, aimed at reduction of the calculated overvoltage ratio;
- transition from the conventional to compact and self-compensating transmission lines of the increased carrying capacity and reduced ecological impact;
- usage of the vegetation arrays to provide the ecological safety of the lines.

5. Conclusions

1. Analysis of the factors and approaches of the normalization of the electromagnetic impact of the overhead transmission lines of 330 kV on ecological systems enables to determine that the world experience regarding the implementation of the overhead transmission lines of the increased carrying capacity and decreased ecological impact, which compact and controlled self-compensating overhead lines are referred, it is expedient to take into account in the process of the object design as compared with the lines of the conventional construction, operated in Ukraine.

2. Technique of the 330 kV the electromagnetic field strength for the determination of their impact on the ecological systems and specification of the sanitary-protection zone width is improved. Unlike other techniques, the given technique takes into account the dimension of the line and sag of the conductor, it is universal because it enables to calculate and analyze of the electromagnetic field of the 330 kV overhead transmission lines of different constructions. Realization of the given technique in the package of programs APM of the designer of the overhead transmission lines will enable determine with greater efficient the main direction in the process of the object design, taking into account electromagnetic situation not only on the route of the line, but also at the distance from it.

References

- [1] Cherkashina V. V., Cheremisin M. M.: Establishment of a priority projecting line in the minds of the day. Proceedings of Controlled power transmission lines 2007–2017, 9, 2017, 50–91.
- [2] Cherkashina V. V., Cheremisin M. M.: In accordance with the method of assessing the tension of electric fields of power transmission lines. Proc. 5th Inter. Sc. and Pract. Conf. Problems and prospects for the development of energy, electrical technology and automation in the agro-industrial complex, 2019, 31–32.
- [3] D'yakov A. F. (ed.): Super- and Ultrahigh Voltage Electrical Networks of the Russian Unified Energy System. Theoretical and Practical Base. STC Energoprogress, Moscow 2012.
- [4] Directive 2013/35/EU. Electromagnetic fields: Social innovation “EaSI” (2014–2020).
- [5] Energy strategy of Ukraine for the period up to 2035 r. “Safety, energy efficiency, competitiveness”. Ordering from September 18, 2017. No. 605-r. <http://www.ukrenergo.energy.gov.ua>
- [6] Hatibovic A.: Advanced Application of the Catenary and the Parabola for Mathematical Modeling of the Conductor and Sag Curves in the Span of an Overhead Line (doctoral thesis). Óbuda University, Budapest 2019.
- [7] International Commission on Non-Ionizing Radiation Protection (ICNIRP): Guidelines for limiting exposure to electromagnetic fields (100 kHz to 300 GHz). Health Physics 118(5), 2020, 483–524.
- [8] Ivanov I. E.: Assessment of the influence of various factors on the values of resistances and conductivities of a high-voltage overhead power line. Bulletin of ISUE 3, 2017, 30–39.
- [9] Morozov Yu. A., Yakobson B. G.: A simplified method for calculating the electric field strength under the wires of high-voltage power lines. Sci. slave. Institute of Labor Protection All-Union Central Council of Trade Unions 103, 1976, 21–23.
- [10] Rules for the regulation of electrical installations. Industry, Kharkiv 2017.
- [11] Singhal A: Volt/var control with high solar PV penetration in distribution systems and its impact on the transmission grid (Theses and Dissertations). Iowa State University, Ames 2019.
- [12] Stam R.: Comparison of international policies on electromagnetic fields. National Institute for Public Health and the Environment, Bilthoven 2018.
- [13] Stam R.: National precautionary policies on magnetic fields from power lines in Belgium, France, Germany, the Netherlands and the United Kingdom. National Institute for Public Health and the Environment, Bilthoven 2018.
- [14] State sanitary norms and rules of protection of the population from the effects of electromagnetic radiation with changes were registered by the Ministry of Justice of Ukraine on May 16, 625/30493, 2017.
- [15] Statement and further consultation: Proposed measures to require compliance with international guidelines for limiting exposure to electromagnetic fields (EMF). Ofcom, 2020.
- [16] Vasilevskiy O. M., Kulakov P. I., Dudatiev I. A. et al.: Vibration diagnostic system for evaluation of state interconnected electrical motors mechanical parameters. Proc. of SPIE 10445, 2017, 104456C.
- [17] Vasilevskiy O., Didych V., Kravchenko A. et al.: Method of evaluating the level of confidence based on metrological risks for determining the coverage factor in the concept of uncertainty. Proc. of SPIE 10808, 2018, 108082C.

D.Sc. Eng. Veronika Cherkashina

e-mail: veronika2473@gmail.com

Doctor of Science (Engineering), associate professor, Department of Electric Power Transmission, Kharkiv National Technical University "Kharkiv Polytechnic Institute", Kyrypchova str., 2, 61002, Kharkiv, Ukraine.



<http://orcid.org/0000-0002-5639-9722>

Ph.D. Svitlana Litvinchuk

e-mail: svtlanalitvinchk@ukr.net

Ph.D. in pedagogy, associate professor of the Department of Methodology of Vocational Training, Faculty of Engineering and Energy, Mykolaiv National Agrarian University. Author of more than 50 publications, including five textbooks and more than 30 scientific articles in professional journals, 7 of them in scientometric databases Web of Science, Google Scholar, Index Copernicus International.



<http://orcid.org/0000-0002-9885-7234>

Ph.D. Vladyslav Lesko

e-mail: leskovlad@ukr.net

Ph.D., associate professor, Department of Power Plants and Systems, Vinnytsia National Technical University, Khmelnytsky highway, 95, 21000, Vinnytsia, Ukraine.



<http://orcid.org/0000-0002-5477-7080>

M.Sc. Svetlana Kravets

e-mail: swkravec2017@gmail.com

M.Sc., research assistant, Department of Technological Processes and Equipment for Processing and Food Industries, Vinnytsia National Agrarian University.



<http://orcid.org/0000-0001-8628-8479>

Ph.D. Volodymyr Netrebskiy

e-mail: netrebskiy@ukr.net

Ph.D., associate professor, Department of Power Plants and Systems, Vinnytsia National Technical University, Khmelnytsky highway, 95, 21000, Vinnytsia, Ukraine



<http://orcid.org/0000-0003-2855-1253>

Ph.D. Olena Sikorska

e-mail: olenasikorska@ukr.net

Ph.D., Department of Power Plants and Systems, Vinnytsia National Technical University, Khmelnytsky highway, 95, 21000, Vinnytsia, Ukraine



<http://orcid.org/0000-0001-7341-9724>

Ph.D. Orken Mamyrbayev

e-mail: morkenj@mail.ru

Deputy Deputy General Director in science and head of the Laboratory of computer engineering of intelligent systems at the Institute of Information and Computational Technologies of the Kazakh National Technical University named after K. I. Satbayev and associate professor in 2019 at the Institute of Information and Computational Technologies. Main research field: machine learning, deep learning, and speech technologies.



<http://orcid.org/0000-0001-8318-3794>

Ph.D. Baglan Imanbek

e-mail: imanbek.baglan18.06@gmail.com

Ph.D., associate professor, Department of AI&BigData, AI Farabi Kazakh National University, Almaty, Kazakhstan.



<http://orcid.org/0000-0001-7249-380X>