

ISSN 2307-5732

DOI 10.31891/2307-5732

НАУКОВИЙ ЖУРНАЛ

1.2024

ВІСНИК

**Хмельницького
національного
університету**

Технічні науки

Technical sciences

SCIENTIFIC JOURNAL

HERALD OF KHMELNYTSKYI NATIONAL UNIVERSITY

2024, Issue 1, Volume 331

Хмельницький

KRASILENKO VLADIMIR

Vinnytsia National Agrarian University

<https://orcid.org/0000-0001-6528-3150>e-mail: krasvg@i.ua**KYCHAK VASYL**

Vinnytsia National Technical University

<https://orcid.org/0000-0001-7013-3261>e-mail: ymkychak@gmail.com**NIKOLSKY ALEXANDR**

Vinnytsia National Technical University

<https://orcid.org/0000-0002-0098-0606>e-mail: fortuna888@i.ua**LAZAREV ALEXANDER**

Vinnytsia National Technical University

<https://orcid.org/0000-0003-1176-5650>e-mail: alexander.lazarev.vntu@gmail.com**NIKITOVYCH DIANA**

Vinnytsia National Technical University

<https://orcid.org/0000-0002-8907-1221>e-mail: diananikitovych@gmail.com

USING MATHCAD AND LABVIEW FOR MODELING ALGORITHMS FOR DETECTION, LOCALIZATION AND TRACKING OF MOVING OBJECTS IN VIDEO STREAMS

In this work, algorithms for detection, localization and tracking of moving objects in a stream of video frames are proposed and modeled. The proposed algorithms and system are based on the use of subtraction operations as well as some other types of operations on sets of adjacent frames. The algorithms are additionally based on non-linear normalized equivalence models that use spatial equivalence functions as descriptors and measures of proximity of the template and the current video frame fragment. The simulation results of the proposed algorithms in Mathcad and LabView are presented. The use of the proposed method, equivalence models and equivalence functions from the processed difference video frames gives good results of recognition and tracking of moving objects. Experiments with a simulation model in Mathcad showed that to improve the quality of tracking systems for moving objects, in conditions when they fall behind obstacles, the best option is to use non-linear spatial equivalence functions instead of mutual correlation spatial functions when processing halftone images of video frames, to compare fragments of the difference current frame shifted along the frame with a reference difference fragment representing the object of attention. The proposed tracking method was implemented in the Labview project, which enabled effective simulation. A number of various experiments with a video file, carried out and presented in the work, showed that the method of forming a video stream from difference video frames, taking into account frame delays depending on the speed of movement of objects, gives better results compared to the method without the formation of difference frames. The proposed system based on the difference frame method combines the tracking process with the process of improved fragment recognition, expands functional capabilities, reduces computational complexity, and allows more accurate determination of the coordinates of the target pointer that moves and follows this object.

Keywords: simulation, video stream, pattern recognition, object detecting, tracking, nonlinear equivalence model, subtraction of frames, space-invariant recognition, Mathcad, Labview.

КРАСИЛЕНКО ВОЛОДИМИР

Вінницький національний аграрний університет

КИЧАК ВАСИЛЬ**НИКОЛЬСЬКИЙ ОЛЕКСАНДР****ЛАЗАРЄВ ОЛЕКСАНДР****НІКІТОВИЧ ДІАНА**

Вінницький національний технічний університет

ВИКОРИСТАННЯ MATHCAD І LABVIEW ДЛЯ МОДЕЛЮВАННЯ АЛГОРИТМІВ ВИЯВЛЕННЯ, ЛОКАЛІЗАЦІЇ ТА ВІДСТЕЖЕННЯ РУХОМИХ ОБ'ЄКТІВ У ВІДЕОПОТОКАХ

У даній роботі запропоновано та змодельовані алгоритми виявлення, локалізації та відстеження рухомих об'єктів у потоці відеокадрів. Запропоновані алгоритми та система базуються на використанні операцій віднімання, а також деяких інших видів операцій над наборами суміжних кадрів. Алгоритми додатково базуються на нелінійних нормалізованих моделях еквівалентності, які використовують функції просторової еквівалентності як дескриптори та міри близькості шаблону та поточного фрагмента відеокадру. Наведено результати моделювання запропонованих алгоритмів у Mathcad та LabView. Використання запропонованого методу, моделей еквівалентності та функцій еквівалентності з оброблених різницевих відеокадрів дає хороші результати розпізнавання та відстеження рухомих об'єктів. Експерименти з імітаційною моделлю в Mathcad показали, що для підвищення якості систем стеження за рухомими об'єктами, в умовах їх відставання від перешкод, найкращим варіантом є використання нелінійних просторових функцій еквівалентності замість взаємних кореляційних просторових функцій при обробці напівтонових зображень відеокадрів, щоб порівняти фрагменти різницевого поточного кадру, зміщеного вздовж кадру, з опорним різницевим фрагментом, що представляє об'єкт уваги. Запропонований метод стеження було реалізовано в проекті Labview, що дозволило проводити ефективне моделювання. Ряд

різноманітних експериментів з відеофайлом, проведених і представлених в роботі, показав, що метод формування відеопотоку з різницевих відеокадрів з урахуванням затримок кадрів в залежності від швидкості руху об'єктів дає кращі результати в порівнянні з до методу без формування різницевих кадрів. Запропонована система на основі методу різницевих кадрів посприє процес стеження з процесом покращеного розпізнавання фрагментів, розширює функціональні можливості, знижує обчислювальну складність і дозволяє точніше визначати координати цільового вказівника, який рухається та слідує за цим об'єктом.

Ключові слова: Моделювання, відеопотік, розпізнавання шаблонів, виявлення об'єктів, відстеження, модель нелінійної еквівалентності, віднімання кадрів, розпізнавання космічного інваріанту.

Introduction

The rapid growth of applications and popularity of many new tools of artificial intelligence, especially such as ChatGPT, neuro-fuzzy decision support information systems, state-of-the-art architectural models and concepts of convolutional neural networks, theories of deep machine learning, have opened almost unlimited prospects for the use of these technologies and tools [1-13]. Increasing productivity, optimizing resources and ensuring sustainable development due to the use of advanced intelligent information technologies, neural associative memory [6-13] and artificial intelligence (AI) [14-19], NN-models [9-11], devices [14-18], can have a significant impact on increasing the efficiency and profitability of information management, both in the production of dual-use products. These modern technologies make it possible to carry out constant monitoring and diagnosis of the environment, agricultural land, forest, water resources and other geographical or territorial objects, to determine indicators and characteristics of the health of individual zones of the plant and animal world and their individual representatives, to quickly collect with the help of drones and sensors systems, IoT devices, large amounts of data and perform their intellectual analysis, forecast yields, weather changes, take into account various weather risks and market trends, help make optimal and weighted decisions based on an expanded set of quantitative and qualitative criteria assessments. To design and create improved biometric systems, identification systems, extreme-correlation guidance systems, neuro-cyber-machine vision and other practical applications, it is necessary to solve the problems of effective recognition of objects in images and scenes, in video frames, as well as the problems of detecting, localizing and identifying moving objects. Tracking of moving objects (English Object Tracking) [19], is a process of determining the movement and localization of objects in real time based on sequential images or a video stream. This technique is used in a wide range of applications, including object tracking in video surveillance, self-driving cars, augmented reality, and medical imaging. Tracking of moving objects can be implemented using various methods, such as the method of principal components, object extraction algorithms, as well as the use of neural networks and computer vision [20-29]. There are many known methods and means for solving these problems [30-32]. But the basis of most known methods and algorithms is the comparison of two different images of the same object or its fragment, or two images, one of which is a template or its transformed image, and the second image is one of a set of images belonging to different objects or classes, and only some of them belong to the class represented by this pattern. The discriminant measure of the mutual alignment of the template and the current, coordinately shifted, fragment of the analyzed image is often a mutual two-dimensional correlation function. In work [32] it was shown that when there is a strong correlation of noisy images of objects from different classes, in order to increase accuracy and other measures, probabilistic indicators, it is desirable to use image matching methods based on mutual two-dimensional equivalence spatial functions, nonlinear transformations and adaptive-correlation weighting. At the same time, there is an acute problem of recognizing not only static, but also moving objects, and problem of their tracking, that is, the problem of tracking is relevant.

In addition, in real systems, the need for recognition arises in such unfavorable situations when a moving object is blocked by obstacles, which deteriorates the quality and accuracy of recognition characteristics, since the size of the area of coincidence between the compared template and the fragment used for recognition is reduced. Therefore, the purpose of this work is to perform a series of model experiments in the Mathcad and other model environments necessary to test improved methods and algorithms for detecting and tracking moving objects with sufficient probability and accuracy.

Model Experiments in Mathcad

To check the accuracy of determining the coordinates of the desired image, especially when recognizing moving objects, in our modeling we used splitting the processed video file into separate frames and their subsequent intra-frame and inter-frame processing. In addition, we carried out a mutual comparison of the two groups of methods used by us for detecting objects in the current frame using the corresponding template. One group of methods included processing the current image frame and a reference template image in order to search for a fragment similar to it in the frame. The second group included the formation of frames equal to the mutual differences of frames adjacent in time, and their further processing in order to detect objects of attention by comparing and combining the template and the fragment most similar to it in the difference frame. In addition, for both groups of methods, the first approach was to search for equivalence functions between the object of attention selected for study and the current fragments of the frame image by processing halftone images. The second approach differed from the first in that the resulting equivalence function is calculated by weighing all eight equivalence functions from the corresponding bit-slice representations of the template and fragment being compared. And the latter are obtained from raster images processed in each frame by pixel-by-pixel analog-to-digital conversion. In both cases, equivalently adaptive nonlinear weighting is additionally used, which enhances the discrimination of the measure used and allows for better identification of extrema (peaks) of two-dimensional spatial functions. Experiments have shown that the best of these options is available by combining equivalent differences comparing the current frame with the selected position from these fragment differences representing objects of attention.

Figure 1 shows a Mathcad window with a processed difference video frame, a template, formulas for calculating spatial nonlinear equivalence functions and their appearance. In Figure 2 shows the simulation results. For both groups, the second method of processing a sequential-slice combination gives the best results, and for moving objects that disappear when they move behind obstacles, recognition of the second group is based on the formation of current frame images of inter-frame difference images (see Figure 2, second image from the right in top row).

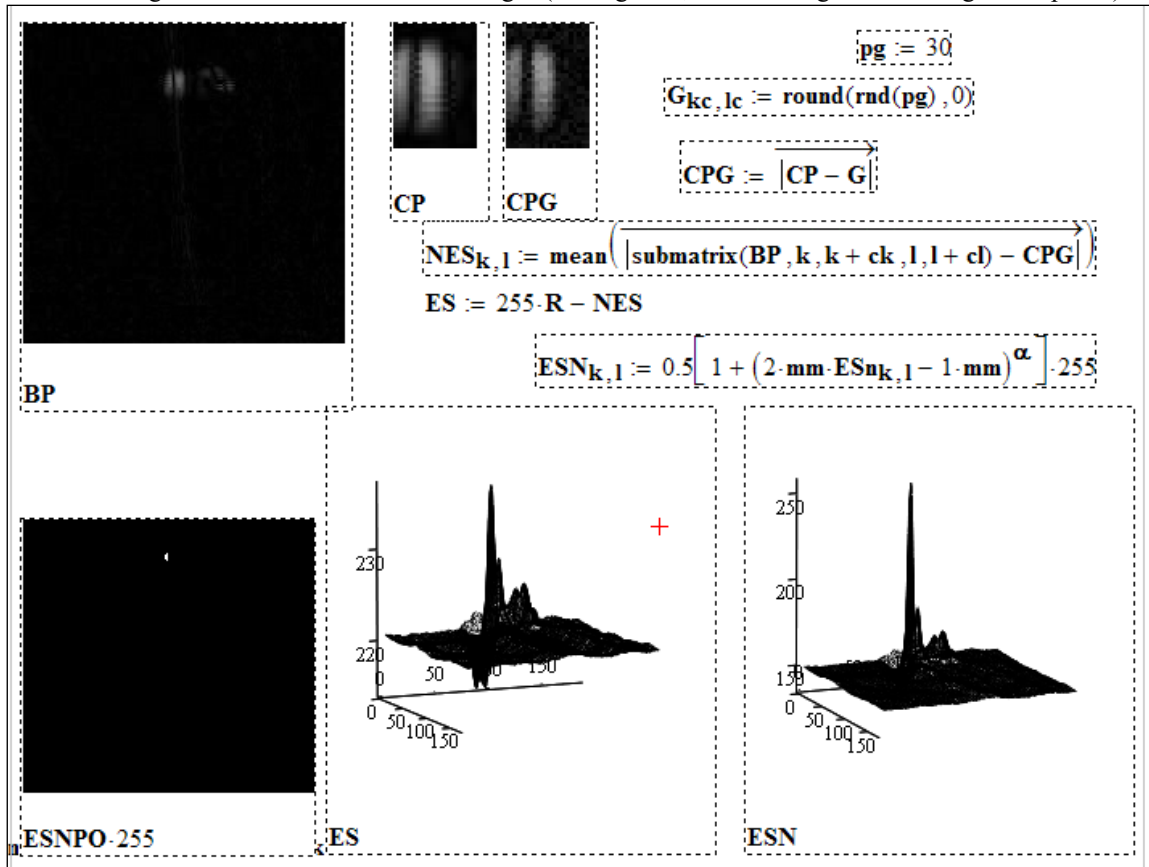

Fig. 1. Mathcad window with processed difference video frame, template, and formulas for calculating spatial nonlinear equivalence functions

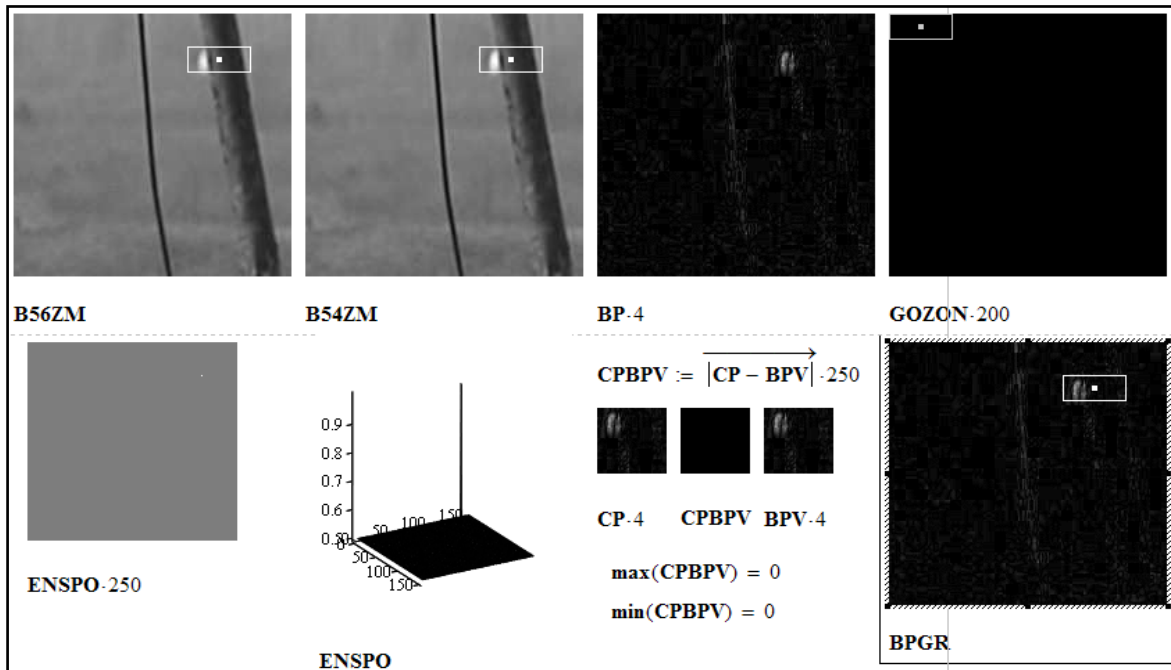

Fig. 2. Model experiments in Mathcad showing adequate detection and labeling of a moving object partially occluded by an obstacle

Experimental Research of Tracking Algorithm of Moving Objects in Labview

Usually tracking algorithms consist of such successive steps: selection and allocation of descriptors, their comparison and classification. At the comparison, a frame fragment, the descriptor of which is the most similar to the descriptor of the tracked object, is searched. When the corresponding fragment is found, then the found object is

classified. When analyzing moving objects, recorded by digital video camera using tracking algorithms, a large number of frames must be processed in the images stream. Counting the number of selected objects in each frame and grouping and clustering by different parameters, including shape, speed, location, etc., are important subtasks. And although each of these subtasks has its own specific image processing algorithms, there is an urgent need to adapt these subtasks to changing specific conditions and to ensure the possibility of their repeated repetition. And this is possible by creating a flexible, easily customizable, unified integrated tool environment.

There are well-established approaches to recognition of very noisy and correlated single objects [33-41] and sets of multiple objects [34, 38, 39], including moving ones [40], with simultaneous division into clusters [34-36, 41]. However, they are all very diverse and poorly integrated into single, flexible and configurable, and adaptive system or program. Therefore, when choosing a tool for research, we settled on Labview as the most powerful hardware system-design platform and development environment created in the graphical programming language «G» company National Instruments (USA).

The NI Vision base module contains a set of optimized functions for working with color, black and white or binary images, including linear, non-linear and morphological filtering of different types and with different structural elements or filter sizes, histogrammed and affine geometric transformations, pattern matching and current fragments, measurement of image parameters of objects after their pre-processing, etc. A large set of functions of this package allows you to use it as an integrated and very convenient environment for comprehensively solving tasks such as recognition and tracking of moving objects in video streams. The NI IMAQ video camera driver software is compatible with all National Instruments software, including NI DAQ. This allows for easy integration image processing for any National Instruments product. The main feature of NI IMAQ is its extensive library special functions. Convenient and functional addition to NI Vision that greatly improves the user experience is the NI Vision Assistant. This makes it easy to create your own routines image capture, filtering, processing, analysis and editing and visualization, changing the setting parameters used for these procedures. These routines can be imported into Labview. Visualization and ease of use are the main advantages of this approach.

Therefore, we chose the Labview environment to automate the search for improved recognition-tracking algorithms and to support moving objects and to develop and verify the proposed trackers. And new pre-processing algorithms that can improve the quality of real-time tracking, location and monitoring of a moving object or several objects, including those partially covered by obstacles, are the result of the proposed research and modeling. New methods of preprocessing, descriptors and image comparison criteria will be presented in the paper.

Experiments conducted to test software implementations in the LabView environment of trackers on real video files are given and analyzed. Harnessing the power of Labview and its basic applications and modules makes it relatively quickly design the required system of recognition and support, to quickly change the behavior, structure and model of the system or process, write, read and analyze video file (AVI) frames, which significantly simplifies the process of verification of developed systems-specific features and statistics. At the same time for in-depth mathematical formalism and describe some of the important stage process, for example, such as the construction of two-dimensional functions of criteria we use Mathcad, which as the results of our previous studies, there is a powerful tool. We have developed a number of possible projects detection and tracking of moving objects (DTMO). Taking into account the limitations, below is one of the possible project options developed by us in the LabView environment for the detection and tracking of moving objects. It is shown in Figure 3 and displays the general block diagram of the project. And fragments and nodes of the basic design of the project, which are also shown in Figure 3, can be better examined and analyzed by specialists when the scale is increased.

With the help of the Vision Acquisition node implemented in the system, the system reads AVI-files to generate both the original video stream and the video stream of difference frames with the possibility of setting different delay times (in frames) between the processed frames. This convenient input and change of the required delay time facilitates the modeling process in order to investigate and determine the optimal frame delay time for different situations and different types of moving objects. And this, as experiments show, is important for moving objects, taking into account the relative sizes (in pixels) of the images of these objects in the directions and speeds of their movement. The template formation node from the selected frame and the comparison of the node template with selected fragments of the current frame are performed using a well-known standard method. But, as will be shown below, such nodes also need to be improved in order to increase their efficiency and improve the quality and criteria of pattern comparison. And one of the options for such improvement is the use of two-dimensional equivalence spatial functions, nonlinear transformations and adaptive-correlation weighting [32, 34-37, 41].

Results of the first experiment in support of a moving car for scenes with overlapping objects obstacles is shown in Figure 4a, (shows one of the frames from which was isolated and formed template, see Figure 4b). Some frames with special red markers (frames) and labels are shown in Figure 4c. This model experiment uses the frames of the original file without preprocessing, the RGB image frame size was 281×126 , the resolution of the 8-bit patterns was 44×24 , and the "Grayscale" mode was used to compare with the current frame pattern, for which the special type of converters and corresponding image formats. The quality of tracking of moving objects by the developed project, and at the same time, essentially, its simulation model, and the quality of continuous tracking of objects with their location markers on video frames was evaluated by the relative share of the number of frames with available markers to the total number of frames in the analyzed video streams during the experiments. The video stream for this analysis was recorded as the video output of the project and was recorded using the Vision Acquisition program, which transformed one of the video streams studied and shown below in this work into a set of 256 frames. The number of

frames in which the moving object (MO) was captured and had a marker frame was determined to be 135. Therefore, the proportion of frames in which the object was not specified was $(135-88) / 135$, which corresponds to approximately 35%. And this is in the case when there are no relatively large barriers, i.e. large immovable objects in the scene, behind which the accompanying moving object disappears.

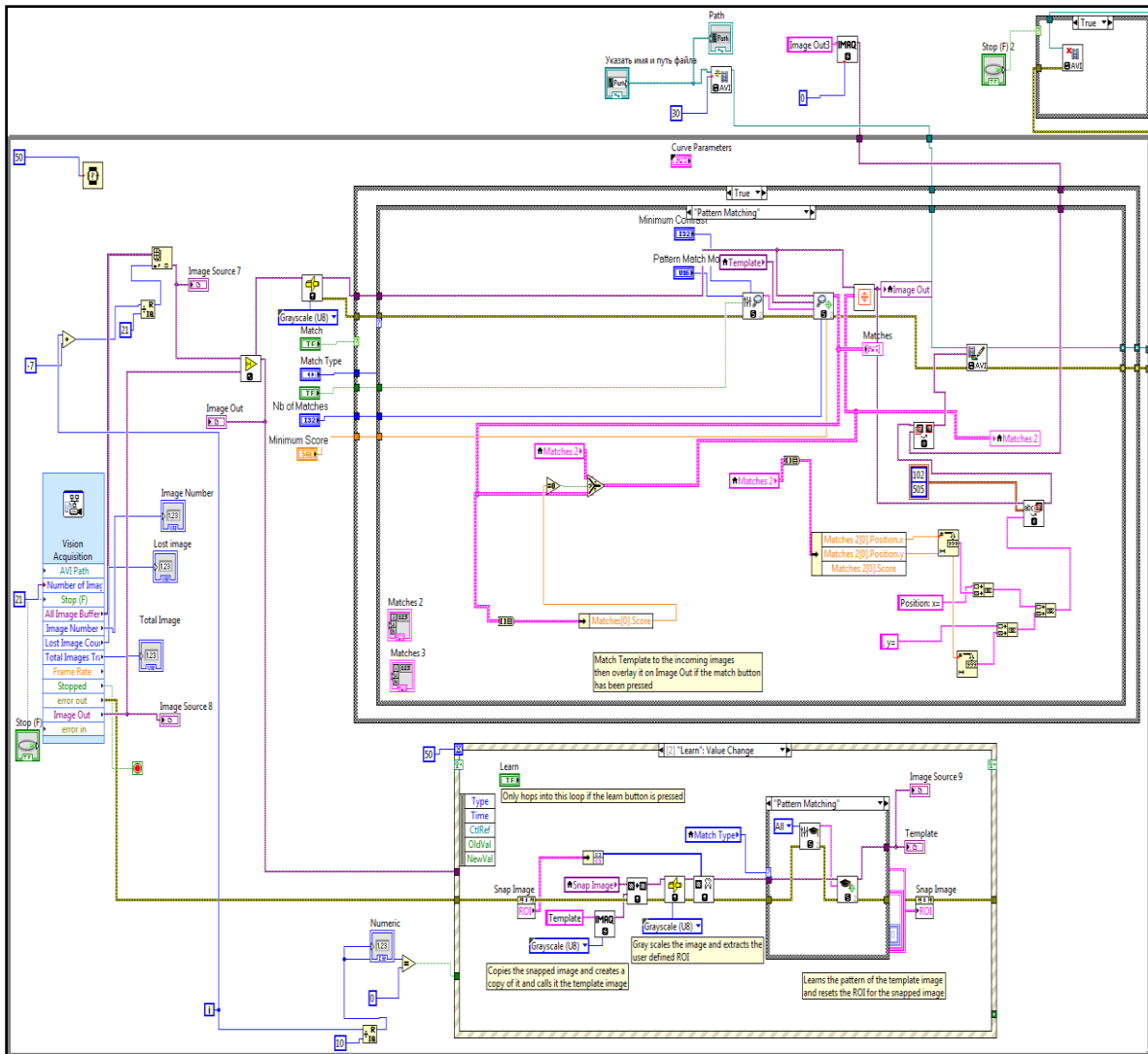

Fig. 3. Block diagram of the project

In this regard, we conducted a second experiment in which watched from the source to the video has been formed from the difference inter-frame video images. Number of frames for which delayed video stream varied between 3 to 7 and more. Figure 5 shows the results of simulation where the difference frames formed by delaying them in frame 7 as an absolute difference of pixel intensities. The experiment showed that the percentage of frames without reference to the moving object, i.e. with the loss of support, depends on the delay time for the inter-frame subtraction, the size of the object, since the difference pattern increases with the delay, the speed of movement relative to the frame rate and shooting conditions, and also on the specific nature scenes.

For example, the camera shake when shooting hand-forms on the difference frames the contours of objects (trees, poles, etc.). In addition, the quality of the support and influence the choice of the template when a template can be selected only some (front, rear) part of the total difference pattern 5b. This experiment showed that for the most optimal video there is a delay of 7 shots, but winning over the first experiment, as there is practically no maintenance. Therefore, an additional check, we tried to work with a video file of larger dimensions (416×125 8bit image) and other shooting conditions. The results for this case are shown in Figure 6. The experiment with the file showed that the quality of support has improved and the proportion of lost bindings decreased to 15% (268 frames in all, 228 with the correct reference, 40 frames in the search mode or a loss of moving object). Thus this and similar experiments, we show that the use of inter-frame subtraction positively affect the quality and support to at least two or three times, but for special occasions, reduces the proportion of errors. Fourth, our experiment was to check the quality of the project in which we used a dynamic pattern and the results of which are shown in Figure 7, where a) - maintenance mode is shown in the processing of the original video frame, and b) - in the processing mode to accompany the video frame difference shown. This experiment showed that such an approach has its advantages and disadvantages, but significant gain compared with the previous experiment does not (error rate was 15%). Further studies are needed.

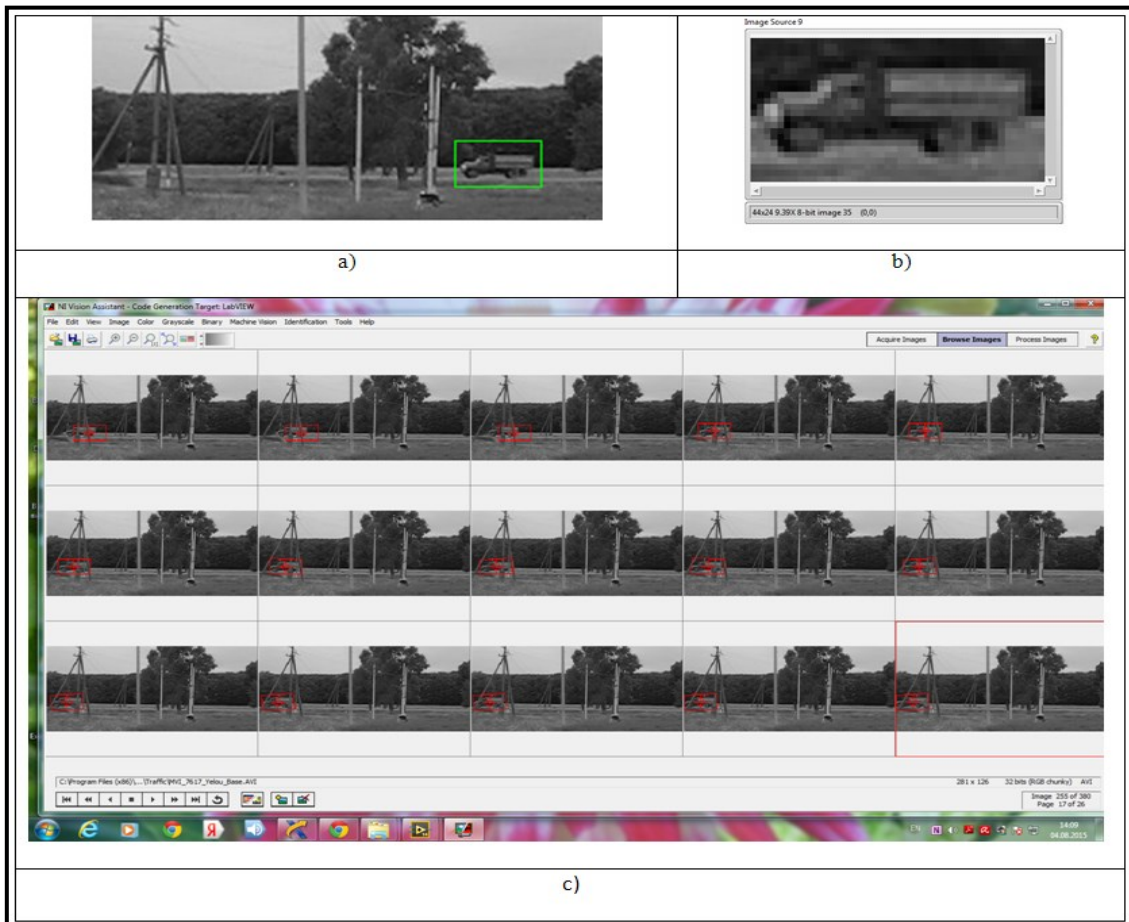

Fig. 4. Modeling results: a) – One of the original frames; b) – Template; c) – Set of frames with markers and pointers of a moving object

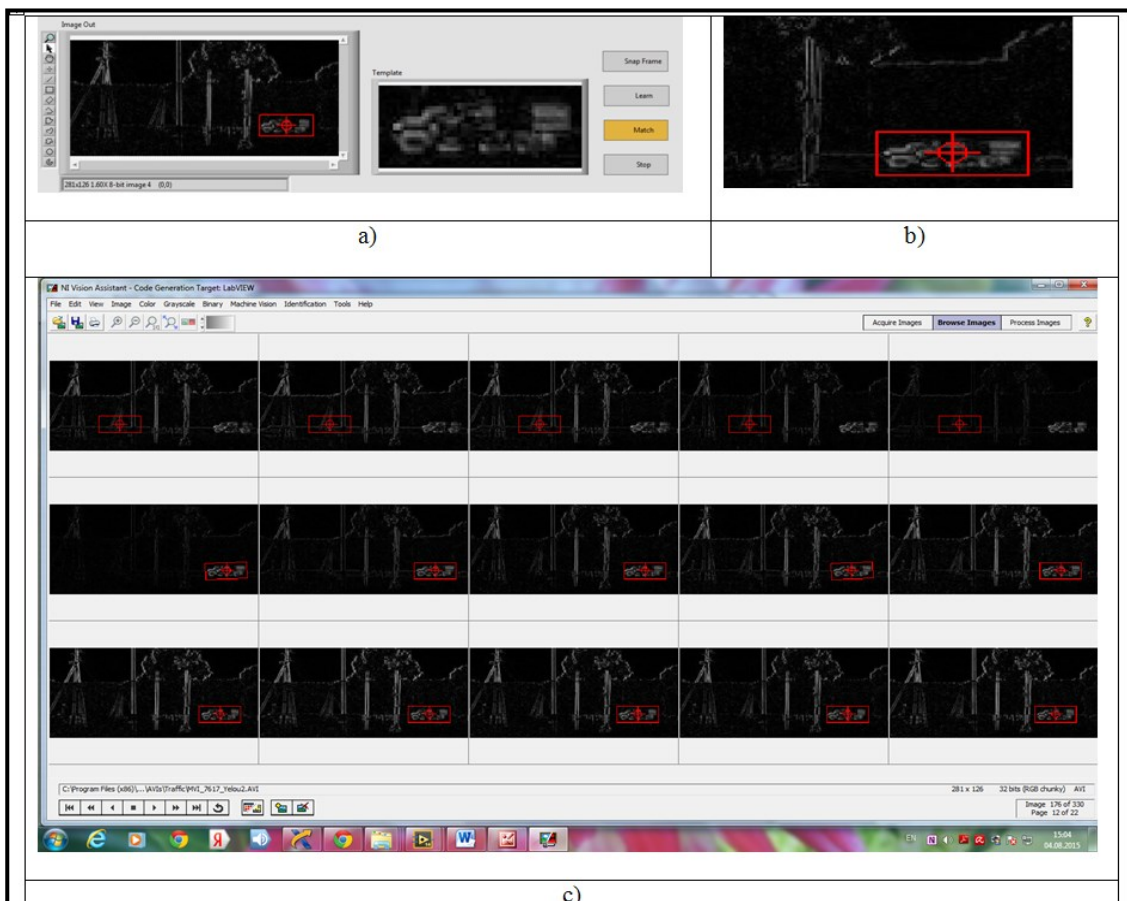

Fig. 5. a) – Difference frame with selected object (left) and a pattern (right); b) – The enlarged area of selected object (difference); c) – Frames with selected object and with loss of the object

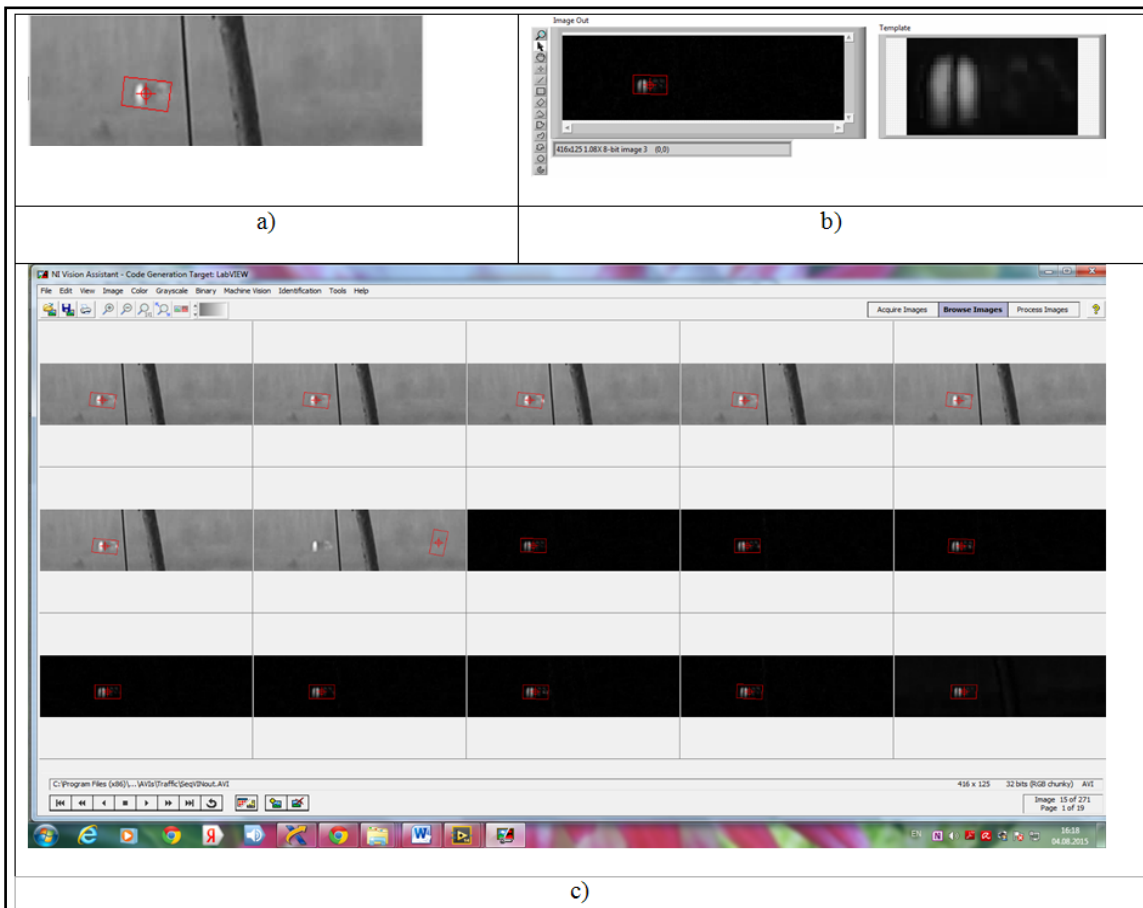

Fig. 6. Modeling results: a) – One of the original frames; b) – One difference from the frame array; c – A set of frames (the original seven and the remaining difference)

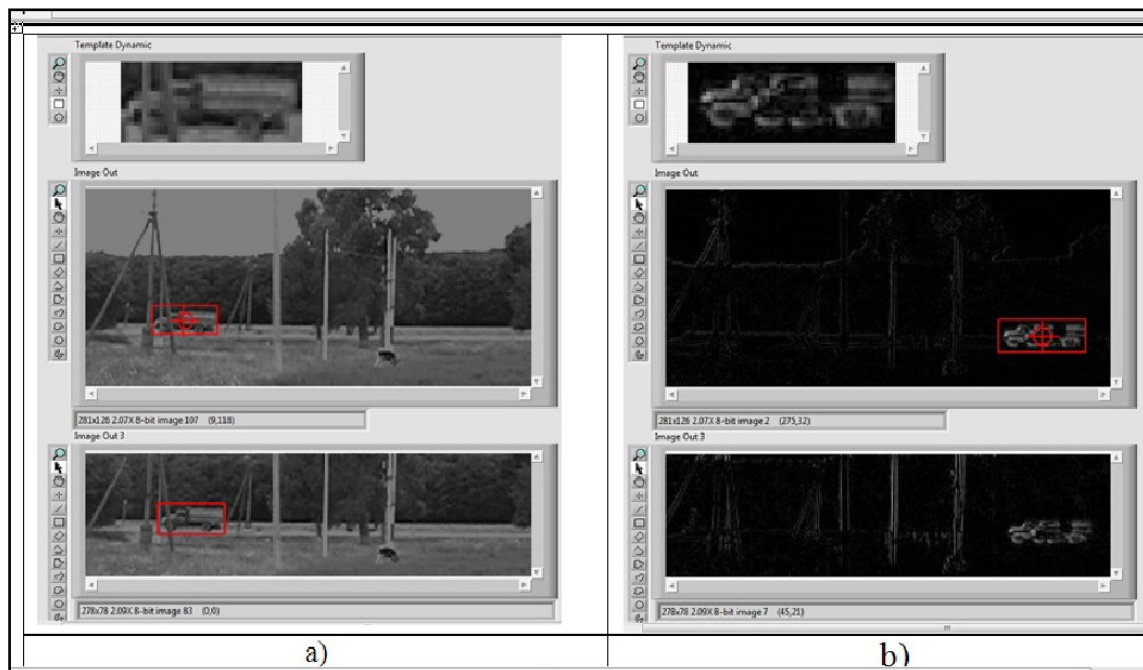

Fig. 7. Modeling results: a) - maintenance mode is shown in the processing of the original video frame and b) - in the processing mode to accompany the video frame difference)

Conclusions

Simulation model experiments in Mathcad showed that in order to improve the quality of tracking systems of moving objects in conditions where they run into obstacles, the best options are the use of non-mutual correlation spatial functions when processing halftone images of video frames, but non-linear spatial equivalence functions, which are used to compare fragments shifted along the frame of the difference current frame with the reference difference fragment representing the object of attention. The proposed tracking method was implemented in Labview, a project

that enabled effective modeling. A number of different experiments with a video file performed and presented in the work showed that the method of forming a video stream from difference video frames, taking into account frame delays depending on the speed of movement of objects, gives better results compared to the method without forming difference frames. In addition, the proposed approach allows you to additionally take into account the peculiarities of the movement of objects and their other characteristics, which also affects the quality of tracking in the event of obstacles. The advantages of using equivalent functions for the comparative analysis of the template and the current fragment in the frame are shown, which consist in more accurate and unambiguous localization of the tracked object in the frame. The difference frame method creates additional opportunities and perspectives because it combines the tracking process with the process of improved recognition of fragments with reduced average dynamic range and computational complexity. Using the characteristic features of the images of the objects themselves and mutual spatial equivalence functions, their extrema, the method allows to more accurately determine the coordinates of the target pointer that moves and follows this object.

References

1. M. Widrich, B. Schäfl, M. Pavlović, H. Ramsauer, L. Gruber, M. Holzleitner, J. Brandstetter, G. K. Sandve, V. Greiff, S. Hochreiter, and G. Klambauer. Modern Hopfield networks and attention for immune repertoire classification. In H. Larochelle, M. Ranzato, R. Hadsell, M. F. Balcan, and H. Lin, editors, *Advances in Neural Information Processing Systems*, volume 33, pages 18832-18845. Curran Associates, Inc., 2020.
2. Yu, Y., Si, X., Hu, C., Zhang, J., 2019. A review of recurrent neural networks: LSTM cells and network architectures. *Neural Comput.* 31, 1235-1270. https://doi.org/10.1162/neco_a_01199.
3. Tait, A. N. Silicon photonic neural networks. PhD thesis, Princeton University, Princeton, 2018.
4. Nahmias, M. A. et al. Photonic multiply-accumulate operations for neural networks. *IEEE J. Sel. Top. Quantum Electron.* 26, 7701518 (2020).
5. P. Seidl, P. Renz, N. Dyubankova, P. Neves, J. Verhoeven, J. K. Wegner, S. Hochreiter, and G. Klambauer. Modern Hopfield networks for few- and zero-shot reaction prediction. *ArXiv*, 2104.03279, 2021.
6. Smith, J., & Johnson, A. (2023). "A Review of Associative Memory Models for Neural Networks." *IEEE Transactions on Neural Networks and Learning Systems*, 34(5), 1234-1246.
7. Zhang, Q., & Li, S. (2021). "Bidirectional Associative Memory for Pattern Recognition in Deep Learning." *IEEE Transactions on Pattern Analysis and Machine Intelligence*, 43(9), 2100-2113.
8. Qun Liu and Supratik Mukhopadhyay. Unsupervised learning using pretrained cnn and associative memory bank. In *2018 International Joint Conference on Neural Networks (IJCNN)*, pp. 01–08. IEEE, 2018.
9. V. G. Krasilenko and A. T. Magas, "Multiport optical associative memory based on matrix-matrix equivalentors," in *Proceedings of SPIE Vol. 3055*, Bellingham, WA, 1997, pp. 137-146.
10. V. G. Krasilenko, A. I. Nikolsky, R. A. Yatskovskaya, and V. I. Yatskovsky, "The concept models and implementations of multiport neural net associative memory for 2D patterns," in *Optical Pattern Recognition XXII*, D. P. Casasent and T.-H. Chao, Eds., *Proceedings of SPIE Vol. 8055*, Bellingham, WA, 2011, p. 80550T.
11. Demircigil M., Heusel J., Lowe M., Uppang S. Vermet F. On a model of associative memory with huge storage capacity. *J. Stat. Phys.* 2017. Vol. 168, N 2. P. 288–299.
12. D. Krotv and J. J. Hopfield. Dense associative memory for pattern recognition. In D. D. Lee, M. Sugiyama, U. V. Luxburg, I. Guyon, and R. Garnett, editors, *Advances in Neural Information Processing Systems*, pages 1172–1180. Curran Associates, Inc., 2016.
13. H. Ramsauer, B. Schäfl, J. Lehner, P. Seidl, M. Widrich, L. Gruber, M. Holzleitner, M. Pavlovic, G. K. Sandve, V. Greiff, D. Kreil, M. Kopp, G. Klambauer, J. Brandstetter, and S. Hochreiter. Hopfield networks is all you need. In *9th International Conference on Learning Representations (ICLR)*, 2021.
14. Li, M., & Wang, Y. (2021). "Associative Memory with Neural Network Architectures for Image Recognition." *IEEE Transactions on Pattern Analysis and Machine Intelligence*, 43(9), 2100-2113.
15. Chen, Z., et al. (2022). "Associative Memory and Pattern Recognition in Neuromorphic Computing." *IEEE Transactions on Cognitive and Developmental Systems*, 14(3), 789-798.
16. Shafiee, A. et al. ISAAC: A convolutional neural network accelerator with in-situ analog arithmetic in crossbars. *ACM SIGARCH Computer Architecture N.* 44, 14–26 (2016).
17. V. G. Krasilenko, A. A. Lazarev, and D. V. Nikitovich, "Design and simulation of optoelectronic neuron equivalentors as hardware accelerators of self-learning equivalent convolutional neural structures (SLECNS)," in *Proc. SPIE 10689, Neuro-inspired Photonic Computing*, 106890C, May 21, 2018, doi: 10.1117/12.2316352.
18. V. G. Krasilenko, A. A. Lazarev, and D. V. Nikitovich, "Design and simulation of array cells for image intensity transformation and coding used in mixed image processors and neural networks," *Proc. SPIE 10751, Optics and Photonics for Information Processing XII*, 1075119 <https://doi.org/10.1117/12.2322655>.
19. Beymer, D., & Konolige, K. (1999). Real-time tracking of multiple people using continuous detection. In *Proceedings of the IEEE Computer Society Conference on Computer Vision and Pattern Recognition* (pp. 214-219).
20. Zhang, Y., & Chan, K. P. (2019). Review of object tracking algorithms. In *Advanced Information and Communication Technology for Sustainable Development* (pp. 375-384). Springer, Singapore.

21. Wang, N., Yeung, D. Y., & Jia, Y. (2013). Understanding and diagnosing visual tracking systems. In *Proceedings of the IEEE International Conference on Computer Vision* (pp. 3101-3108).
22. Cho, M., Choi, J., & Yu, W. (2021). Deep learning-based object tracking: a review. *The Visual Computer*, 1-16.
23. Bhatia, V., Tyagi, V., & Roy, S. (2021). Multi-object tracking using machine learning: A review. *IET Image Processing*, 15(4), 641-656.
24. Chen, Q., Yuan, Y., & Zhang, Y. (2020). Efficient and accurate object tracking: A review. *Signal Processing: Image Communication*, 88, 115991.
25. Zhang, Q., Xu, X., & Wang, J. (2019). A survey on visual object tracking. *Computer Vision and Image Understanding*, 177, 21-52.
26. Li, Z., Wang, X., & Liu, Z. (2019). Deep learning for visual tracking: A comprehensive review. *Neurocomputing*, 356, 1-16.
27. Zheng, M., Wu, Y., & Zhao, J. (2018). Object tracking: A survey. *International Journal of Image and Graphics*, 18(04), 1850013.
28. Liu, B., He, G., & Wang, Y. (2018). A survey of recent advances in visual object tracking. *Frontiers of Information Technology & Electronic Engineering*, 19(12), 1591-1611.
29. Yan, S., Luo, B., & Tian, Q. (2017). Object tracking: a survey. *International Journal of Automation and Computing*, 14(2), 119-138
30. V. G. Krasilenko, A. I. Nikolsky, A. V. Zaitsev, V. M. Voloshin, "Optical pattern recognition algorithms on neural-logic equivalent models and demonstration of their prospects and possible implementations," in *Proceedings of SPIE*, vol. 4387, Bellingham, WA, 2001, pp. 247-260.
31. V. G. Krasilenko, A. I. Nikolsky, and Y. A. Bozniak, "Recognition algorithms of multilevel images of multicharacter identification objects based on nonlinear equivalent metrics and analysis of experimental data," in *Управляющие системы и машины*, vol. 4, 2013, pp. 12-19.
32. V. G. Krasilenko, Y. A. Boznyak, and G. N. Berozov, "Modelling and comparative analysis of correlation and mutual alignment equivalence functions," in *Science and learning process: scientific and methodical*, VSEI Entrepreneurship University "Ukraine", Vinnitsa, 2009, pp. 68-70.
33. V. G. Krasilenko, A. A. Lazarev, S. K. Grabovlyak, and D. V. Nikitovich, "Using a multi-port architecture of neural-net associative memory based on the equivalency paradigm for parallel cluster image analysis and self-learning," in *Proceedings of SPIE*, vol. 8662, Bellingham, WA, 2013, paper 86620S.
34. V. G. Krasilenko, S. K. Grabovlyak, and D. V. Nikitovich, "Experimental research of methods for clustering and selecting image fragments using spatial invariant equivalent models," in *Proceedings of SPIE*, vol. 9286, 2014.
35. V. G. Krasilenko, and D. V. Nikitovich, "Experimental studies of spatially invariant equivalence models of associative and heteroassociative memory of 2D images," in *Information processing systems: a collection of scientific papers*, Ivan Kozhedub Kharkiv Air Force University, Kharkiv, 2014, vol. 4 (120), pp. 113-120.
36. V. G. Krasilenko and D. V. Nikitovich, "Researching of clustering methods for selecting and grouping similar patches using two-dimensional nonlinear space-invariant models and functions of normalized 'equivalence'," in *VII Ukrainian-Polish scientific SPC "Electronics and information technologies" (ELIT-2015)*, Lviv, 2015, pp. 129-134.
37. V. G. Krasilenko, A. I. Nikolsky, and J. A. Flavitskaya "The Structures of Optical Neural Nets Based on New Matrix_Tensor Equivalent Models (MTEMs) and Results of Modeling" ISSN 1060_992X, *Optical Memory and Neural Networks (Information Optics)*, Vol. 19, No. 1, © Allerton Press, Inc., pp. 31-38, 2010.
38. V. G. Krasilenko, A. I. Nikolsky, and Y. A. Bozniak, "Recognition algorithms of multilevel images of multicharacter identification objects based on nonlinear equivalent metrics and analysis of experimental data," in *Sensor Fusion: Architectures, Algorithms, and Applications VI*, B. V. Dasarathy, Ed., *Proceedings of SPIE*, vol. 4731, Bellingham, WA, 2002, pp. 154-163.
39. V. G. Krasilenko, A. A. Lazarev, and S. K. Grabovlyak, "Design and simulation of a multiport neural network heteroassociative memory for optical pattern recognitions," in *Proceedings of SPIE Vol. 8398*, Bellingham, WA, 2012, p. 83980N.
40. V. G. Krasilenko, A. I. Nikolsky, and A. A. Lazarev, "Modeling optical pattern recognition algorithms for object tracking based on nonlinear equivalent models and subtraction of frames," in *MIPPR 2015: Pattern Recognition and Computer Vision*, T. Zhang and J. Liu, Eds., *Proceedings of SPIE*, vol. 9813, Bellingham, WA, 2015, paper 981302.
41. V. G. Krasilenko, A. A. Lazarev, and D. V. Nikitovich, "Modeling and possible implementation of self-learning equivalence-convolutional neural structures for auto-encoding-decoding and clusterization of images," in *Proc. SPIE 10453, Third International Conference on Applications of Optics and Photonics*, 22 August 2017, paper 104532N. doi: 10.1117/12.2276313; <http://dx.doi.org/10.1117/12.2276313>