

ISBN 978-83-66216-32-7

**Sinchuk I.O., Boiko S.M., Gavrilyuk Yu.M.,
Nekrasov A.V., Rykov H.Yu.,
Borisenko O.M., Bilyk A.O., Petulko M.S.,
Ivanchenko L.V., Zhukov O.A.**

SMART INTELLIGENT AUTOMATION OF POWER SYSTEMS

Multi-authored monograph

As amended by DSc. (Engineering), Prof. Sinchuk O.M.

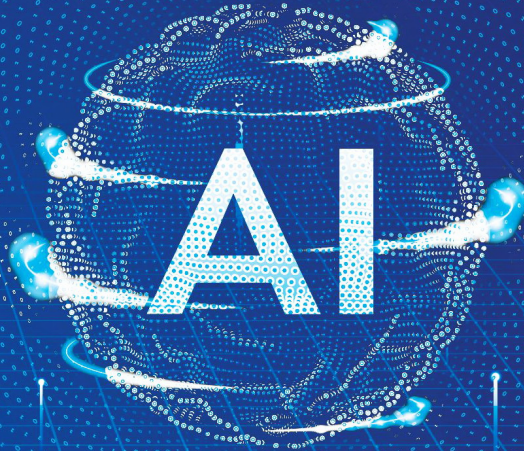

 **iScience**

Warsaw, Poland - 2020

I.O. Sinchuk, S.M. Boiko, Yu.M. Gavrilyuk,
A.V. Nekrasov, H.Yu. Rykov,
O.M. Borisenko, A.O. Bilyk, M.S. Petulko,
L.V. Ivanchenko, O.A. Zhukov

**SMART INTELLIGENT AUTOMATION
OF POWER SYSTEMS**

Multi-authored monograph

**As amended by
DSc. (Engineering),
Prof. Sinchuk O.M.**

Warsaw-2020

UDC 622:621.31

Authors:

Sinchuk I. O., Boiko S. M., Gavrilyuk Yu. M., Nekrasov A. V., Rykov H. Yu., Borisenko O. M., Bilyk A. O., Petulko M. S., Ivanchenko L. V., Zhukov O. A.

Recommended for publication by the Academic Council of the Kryvyi Rih National University of the Ministry of Education and Science of Ukraine
(Minutes #9, June 30)

Reviewers:

O. I. Sablin, DSc. (Engineering), Prof., (Dnipropetrovsk National University of Railway Transport named after Academician V. Lazaryan, Dnipro)

P. G. Pleshkov, PhD (Engineering), Prof., (Kirovohrad National Technical University, Kropyvnytskyi)

Smart intelligent automation of power systems. Multi-authored monograph / I.O. Sinchuk, S.M. Boiko, Yu.M. Gavrilyuk, A.V. Nekrasov, H.Yu. Rykov, O.M. Borisenko, A.O. Bilyk, M.S. Petulko, L.V. Ivanchenko, O.A. Zhukov; Edited by DSc., Prof. O.M. Sinchuk. – Warsaw: iScience Sp. z.o.o. – 2020. – 114 p.

The basic concepts of present-day aspects, prospects and techniques of electric power systems diagnostics are reviewed in the monograph. The paper explores general provisions on electric power equipment diagnostics and tools, procedural and organisational issues of its realization.

Recommended for specialists, post-graduate students and students specialising in 141 – «Power engineering, electrical engineering, electromechanics» and in other related professions.

ISBN 978-83-66216-32-7

© I.O. Sinchuk, S.M. Boiko, Yu.M. Gavrilyuk,
A.V. Nekrasov, H.Yu. Rykov, O.M. Borisenko,
A.O. Bilyk, M.S. Petulko, L.V. Ivanchenko,
O.A. Zhukov, 2020
© iScience Sp. z o. o.



A word to the Reader...

The given monograph is logical extension of "Smart intelligent automation of power systems" by I.O. Sinchuk, S.M. Boiko, Yu. M. Gavrilyuk, A. V. Nekrasov, H. Yu. Rykov, O. M. Borisenko, A.O. Bilyk, M.S. Petulko, L.V. Ivanchenko and O.A. Zhukov.

Another monograph. Honestly, I did not count. There were too many. The authors of this one are mostly my pupils including my colleagues and friends. What is the purpose of writing this book? What is the target audience? We did not consider these issues while working at this paper. We target a wide range of specialists - electricians, mining technologists, students, postgraduates, etc. We also hope to be satisfied by the work done and would be glad if someone finds this work useful.

People may either praise it or criticize. In any case we hope our readers to appreciate our efforts.

The main thing is it is worth reading.

O. Sinchuk

TABLE OF CONTENTS

LIST OF ABBREVIATIONS	6
INTRODUCTION	7
CHAPTER 1 GENERAL ISSUES ON INTRODUCING NON-CONVENTIONAL AND RENEWABLE SOURCES OF ELECTRIC ENERGY	9
1.1 Review of methods of renewable energy introduction and further development in the world and Ukraine	9
1.2 Features and trends of modern power industry development ...	17
1.3 Diagnostics in the life cycle of electrical equipment components	20
1.4 Characteristic of the electrical equipment components’ diagnostic methods	23
1.5 Defect symptoms and their detection methods	25
1.6 Defect location algorithm	27
1.7 Diagnostic parameters forecasting	31
List of references for chapter 1	44
CHAPTER 2 COMPUTER SECURITY AND PROTECTION INFORMATION	46
2.1 Security services and mechanisms of its violations	48
2.2 Development of information technologies.....	54
2.3 Systems of artificial intelligence	56
List of references for chapter 2	60
CHAPTER 3 NORMS, REQUIREMENTS AND LABOUR PROTECTION USING COMPUTER TECHNIQUE	62
3.1 Generals of labour protection using computer technique	62
3.2 Lights of general lighting	66
3.3 Dangers in working with computer	70
List of references for chapter 3	74
CHAPTER 4 METHODS OF CHOOSING SCHEME SOLUTIONS FOR INTRODUCING NON-CONVENTIONAL AND RENEWABLE ENERGY SOURCES AT IRON ORE MINING ENTERPRISES	76
4.1 Methods of assessing the potential of non-conventional and renewable electric energy sources while introducing them at iron ore mining enterprises.....	76
4.2 Assessment of the wind potential at iron ore open pit dumps ..	79
4.3 Assessment of solar photoenergy potential at open pit dumps of iron ore mining enterprises	82

4.4 Peculiarities of scheme solutions for applying wind power plants at iron ore enterprises	85
4.5 Peculiarities of scheme solutions while applying solar power plants at iron ore mining enterprises	88
4.6 Peculiarities of scheme solutions while introducing Micro Grid at iron ore mining enterprises	90
List of references for chapter 4	91
CHAPTER 5 RESEARCH OF AVIONICS RADIO COMMUNICATION CHANNELS	96
5.1 Problem analysis and research problem	97
5.2 Model element developing of the channel radio	100
5.3 Development of the mathematical model of the radio channel.	103
5.4 Development of a model of software functions for conversion of received signals of the receiver	106
List of references for chapter 5	110

LIST OF ABRIVIATIONS

NERC	National Electricity Regulatory Commission
NEURC	National Energy and Utilities Regulatory Commission
KZRK	Kryvyi Rih Iron Ore Works
SHP	Skip hoist plant
CSP	Crushing and sizing plant
RCPCMD	Regional compressor plant of central mine drainage
TD-M	Thyristor drive-motor
G-M	Generator-motor
FC-SM	Frequency converter-synchronous motor
TDC-M	Thyristor direct current-motor
DCM	DC motor
SM	Synchronous motor
CPCM	Complex power consumption management
TC-M	Thyristor converter-motor

INTRODUCTION

Operational reliability of power supply systems electrical equipment is one of the key factors having a significant impact on economic performances of Ukraine's power supply systems. From this perspective, enhancement of electrical equipment operating procedures in the electric power systems of various levels presents particular interest.

It should be noted that reliability indexes enable evaluating an average object state. This results in obtaining overestimated values in some cases and underestimated values in other cases. Technical diagnostics allows evaluating a state of a particular object.

Electric power units are considered as the diagnosis object; the electric power units refer to the totality of machines, devices, power transmission lines, designed for electric power generation, transformation, transmission, distribution and conversion into other kind of energy. The electric power units comprise: generators, power transformers, autotransformers, reactors, voltage and current transformers, power transmission lines, switchgear, package transformer substations, distribution networks, electric motors, capacitors, automatic control and protection devices, various electric users.

Squirrel-cage induction motors are widely used in electromechanical systems nowadays. They have a number of advantages, namely: high reliability of an induction motor due to the absence of a commutator-and-brush unit; high reliability due to the absence of energized operating contactor devices; minimized maintenance of a converter and a near absence of maintenance required for induction motors; a lean operation of an induction motor due to the absence of starting resistors and individual control; high anti stalling properties due to the rigid speed/torque ratio of an induction motor $M=f(n)$. However, induction motor drives possess the following drawbacks: considerable size and high, as compared to DC systems, cost of electric equipment (generally converting and data equipment). Nevertheless, high initial capital expenditures are compensated in a short time by really low operation cost.

The existing maintenance and preventive control system for electric power units is generally based on periodic scheduled maintenance operations, in other words, it is based on the maintenance upon the completion of the specified operation period. Such a system is not optimal though for high voltage devices that results in unjustified scheduled outages of operable equipment.

It is desirable to know the actual condition of an object; it can be achieved by its control. Completing the tasks of technical diagnostics it is possible to sustain the electric power units' reliability while adopting the

maintenance system, where time and scope of works are defined by the equipment condition. It requires creation of an efficient technical diagnostic system. The implemented diagnostics system keeps electric power units condition within certain limits.

The development of diagnostic support system calls for a study of electric power units operating conditions, identification of their key influencing factors, evaluation of electrical equipment reliability indexes, compiling the mathematical description of the object and obtaining a diagnostic model on its basis, its analysis and selection of diagnostic features, assessment of the selected features probability, selection of diagnostic tools, control points, communication and processing means.

When an electric power unit is designed, it should be adapted for diagnosis and self-healing, while it is manufactured – it should be serviceable, and while in operation - it should assure sustainable operational condition. Diagnostic methods and means are tools to sustain the given reliability.

This multi-authored monograph successively examines the diagnosis methods used for electric power units components, the issues of designing diagnostic systems for electric power units; electrical engineers' familiarization with these subjects will facilitate the decision-making in design and operation of the power supply systems electrical equipment.

CHAPTER 1

GENERAL ISSUES ON INTRODUCING NON-CONVENTIONAL AND RENEWABLE SOURCES OF ELECTRIC ENERGY

1.1 Review of methods of renewable energy introduction and further development in the world and Ukraine

Analytical Note #13 of The Ukrainian Bioenergy Association considers the current state and further development of renewable energy in the world, the European Union and Ukraine. It analyzes energy strategies of the EU in general and those of some EU and the world countries in particular, including Ukraine, focusing on the role of renewable energy sources (RES) in these important directions. Special attention is paid to the countries setting a goal of reaching 50% of renewable energy in the total energy consumption by 2050. It is shown that to achieve the goal it is necessary to not only increase renewable energy capacities, but also reduce total consumption of primary energy by introducing energy-efficient steps [1-3].

In 2012, the International Energy Agency prepared the analysis and three scenarios of our planet's development on the basis of various energy priorities. Scenario *2B8* which implies the average temperature increase by 2° C by 2050 is the most attractive and safest of all. To make this scenario come true, considerable changes should be introduced into the world energy system including double reduction of greenhouse gasses by 2050 compared with 2010. To fulfill Scenario *2DS* the energy intensity of the world economy should be decreased on a constant basis as well as the demand for energy (Fig. 1.1, 1.2). Without such reduction, it is too expensive and even impossible to achieve Scenario *2DS* [3].

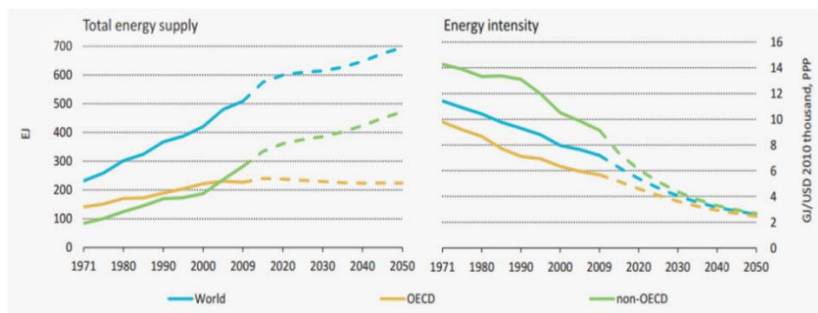

Figure 1.1 – Dynamics of total energy supply and intensity per a GDP unit under Scenario *2DS*

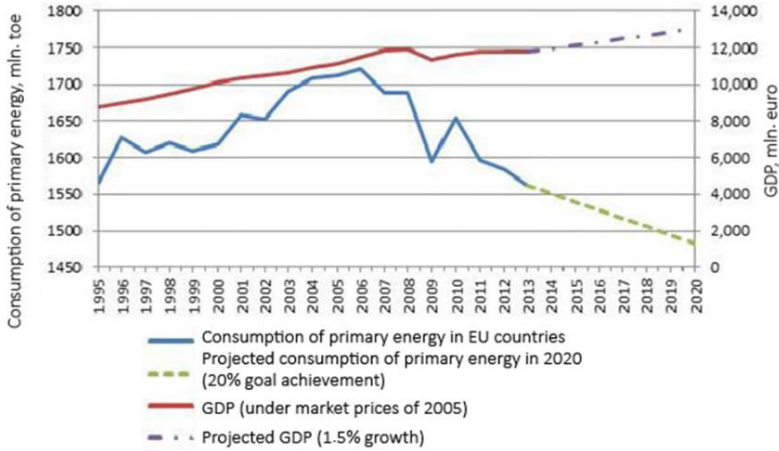

Figure 1.2 – Dynamics of primary energy consumption and GDP in EU-28

At present, renewable energy sources supply about 19% of the world final energy consumption, including conventional biomass – 9%, modern renewable energy sources – above 10% (generation of thermal and electric energy, the transport sector) (Fig. 1.3). In general, conventional and non-conventional biomass covers about 14% of the final energy consumption [1].

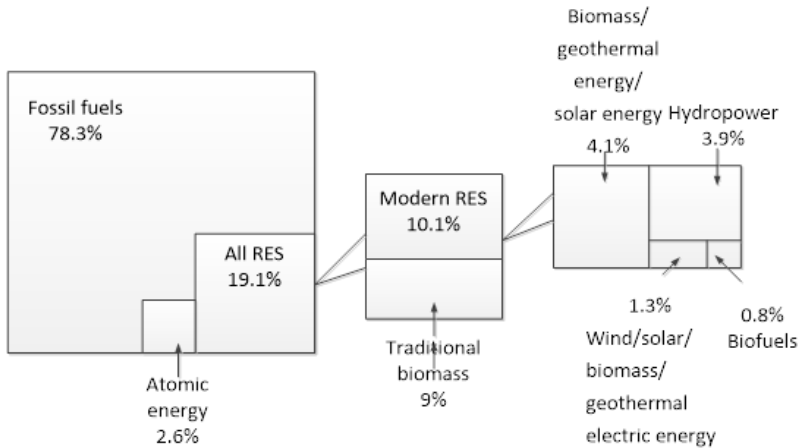

Figure 1.3 – The structure of the world final energy consumption in 2013

Renewable energy sources make up about 22.8% of the total energy production in the world, the major part being hydropower (16.6%). Wind energy and biomass are 3.1% and 1.8% correspondingly (Fig. 1.4) [1].

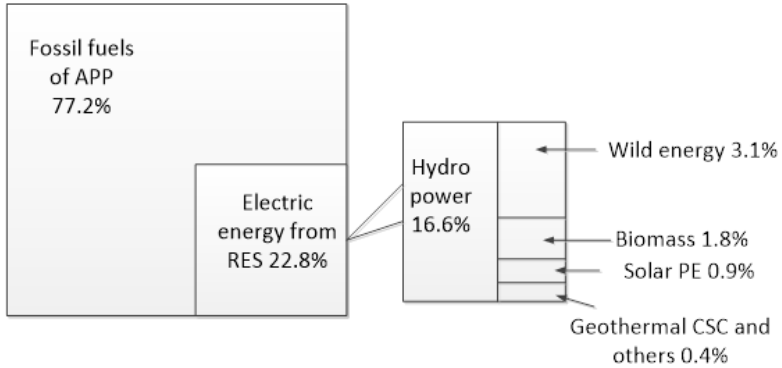

Figure 1.4 – The structure of the world electric energy production in 2014

China, the USA, Germany, Italy, Spain, Japan and India are the major producers of “green” electric energy, which together generate 71.5% of the world total capacity (470GW without hydropower) (Fig. 1.5) [1].

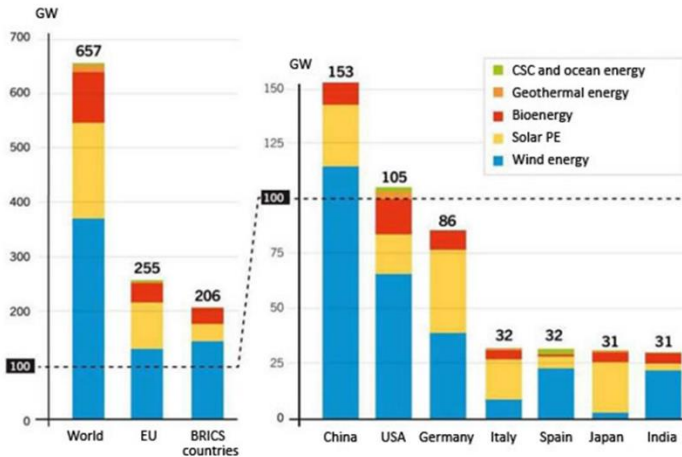

Figure 1.5 – Established electric capacity of the world RES, 2014

The International Renewable Energy Agency (IRENA) worked out the Road Map of doubling the RES fraction in the world energy consumption during 2010-2030 (*REmap2030*) from 18% in 2010 to 36% in 2030. Modern RES are to supersede conventional biomass gradually. As in 2010 conventional biomass made half of 18% of RES, the fraction of modern RES is to triplicate and make up to 30% by 2030 while conventional biomass will account for only 6% (Fig. 1.6) [1].

It is interesting to compare the Road Energy Map *REmap2030* of the IRENA with the forecasting of the World Energy Council (WEC). The WEC developed two scenarios of the world energy development up to 2050 [2]. Scenario 1 (“Jazz”) provides a rather

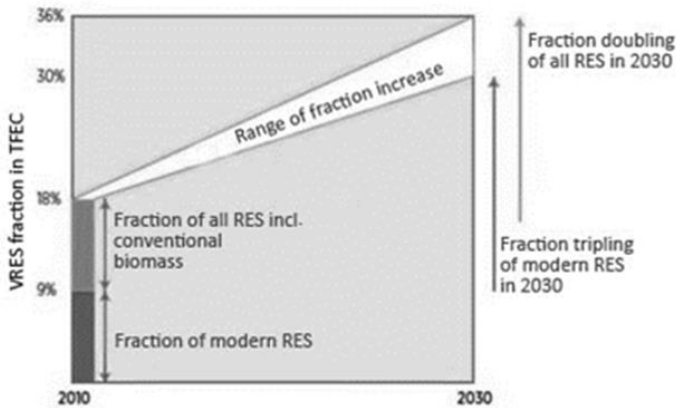

Figure 1.6 – Plans of doubling RES fraction in the total final energy supply of the world according to the *REmap 2030* (IRENA)

slow development of RES making 20% of the total primary energy supply in 2050 and a considerable increase of the total primary energy supply by 38% compared with 2010 (from 546 J/year in 2010 to 879J/year in 2050). This scenario seems to have little chance of working as its objective as for RES has already been achieved. Scenario 2 (“Symphony”) is more probable. It provides predominant development of RES and increase in energy efficiency. Thanks to this, the RES fraction may reach about 30% in the total primary energy supply and make 50% of electric energy production. At the same time, the total energy supply in 2010-20150 will increase by 22% only [3].

In the European Union, the development level of renewable energy is close to the world average indices. RES contribution to the final energy supply accounts for 15% (2013), including biomass (about 9%). The RES fraction in electric energy generation makes 25.4% including about 5% of

biomass. More than 19% of the total thermal energy in the EU is produced from RES, mostly biomass [3].

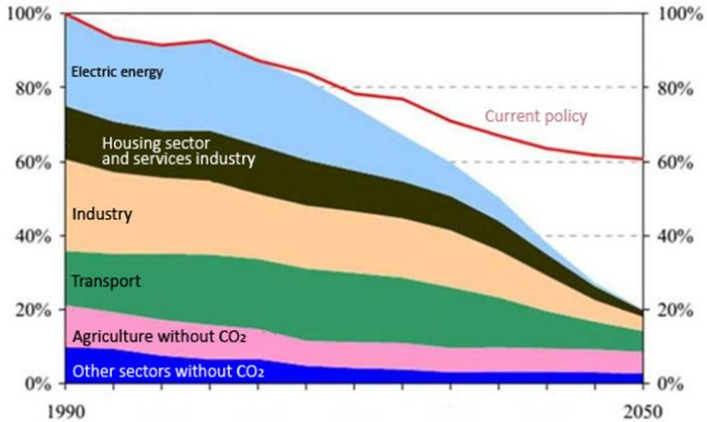

Figure 1.7 – The strategy of reducing greenhouse gas emissions in the EU by 80% by 2050 compared with 1990 according to the EU countries’ obligations

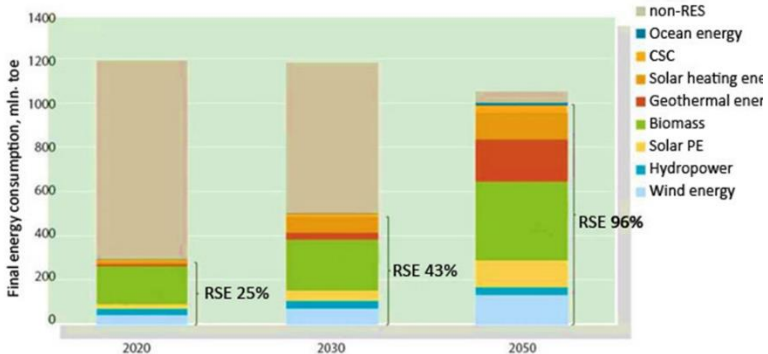

Figure 1.8 – Contribution of RES to the final energy supply in the EU according to “RE-Thinking 2050” (EREC)

In 2011, the EU confirmed its official objective of reducing greenhouse gas emissions (decarbonization) by 80-95% in 2050 compared with those in 1990 in order to follow Climate Change Scenario 2DS (Fig. 1.7) [4]. Considering this, the European Commission developed the *Road Energy Map up to 2050* [9], which analyzed the ways of reducing

greenhouse emissions and enhancing reliability and competitiveness of energy supply systems.

It is worth mentioning that “RES Scenario” complies to the projected prospects of the EU energy development prepared by the European Council with RES (EREC), «IRE-Thinking 2050» [11]. The EREC analysis reveals real possibilities of covering the EU energy needs by almost 100% in 2050 due to RES application (Fig. 1.8) [4].

Table 1.1 provides data on key indices of long-term energy strategies of some world countries [5].

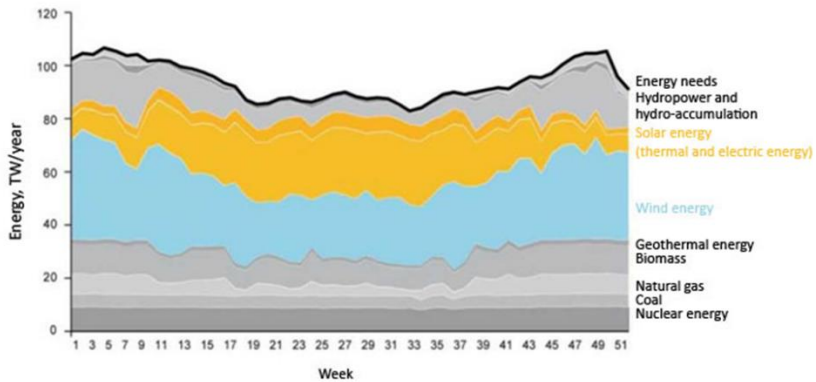

Figure 1.9 – Yearly energy balance, RES fraction of 80%

Constant increase of consumption volumes of energy carriers to meet energy needs make politicians search for new solutions. One of the widely spread solutions in the EU is the idea of a united energy system aimed at leveling the loads and peaks as well as optimal application of various RES in energy generation. In winter periods, more electric energy is produced by wind power plants located in northern EU countries, in summer – by solar power plants located in southern countries. By 2050, it is planned to cover 80% of the total energy production by RES and the main “flow” is expected in directions of “Spain-France” (47GW of the established capacity) and “France-Germany” (20 GW) (Fig. 1.9) [6].

Table 1.1 – RES fraction of in the gross final energy consumption of some world countries according to official data on their energy strategies

Country	2014	2020	2030	2040	2050
Austria	30%	34% 16% ⁴⁾ (1990) 17% ⁵⁾ (2005)			
Denmark	25% 20% ⁵⁾ (2005)	33%	55%	68%	100%
Wales	12,4% (in 2013) 27% ⁴⁾ (1990) 9% ⁵⁾ (2008)	18% 40% ⁴⁾ (1990) 20% ⁵⁾ (2008)	30% 55% ⁴⁾ (1990) 30% ⁵⁾	45% 70% ⁴⁾ (1990) 40% ⁵⁾ (2008)	60% 80% ⁴⁾ (1990) 50% ⁵⁾ (2008)
Sweden	52,1% (in 2013)	50% 40% ⁴⁾ (1990) 20% ⁵⁾ (2008)	100% ³⁾		100% ⁴⁾
Switzerland	17,5% (in 2010)	45% 16% ⁵⁾		56% (in 2035) 45% ⁵⁾ (in 2035)	60%
India	13% ¹⁾ (in 2015)		40% ²⁾ 33-35% ⁴⁾		
China	13% (in 2010)			55% ¹⁾	
USA	20%	30%	40%	70%	100% (in 2015)
Costa-Rika	95-99% 100% ¹⁾ (in 2015)	100% ⁴⁾ (in 2021)			
Island	99%				
Saudi Arabia	1% (in 2015)			100%	

Notes: the year of comparison or index achievement is in brackets

1) In electric energy generation 2) Fraction of energy generating capacities per RES 3) In the transport sector 4) Reduction of greenhouse gas emissions.

5) Energy efficiency increase

Currently, the Energy Strategy of Ukraine for the period up to 2030 is valid [10], which was adopted by the Cabinet of Ministry of Ukraine on 24 July 2013 and strongly criticized at once. In order to solve this problem, some projects of a new document, the Energy Strategy for the period up to 2035, have been developed.

The basic configuration of the energy security formula includes energy saving and energy efficiency + the country's own energy resources (coal, natural gas, uranium ore, oil, biomass + other renewable energy sources) + import diversification + strategic reserves + integration into the

EU energy space (united and synchronized energy networks) + protection of the critical energy infrastructure [12].

In 2015, the structure of primary energy resource consumption is characterized by a great fraction of natural gas (36.1%, 31 mln toe) in the total primary energy supply. Atomic energy accounts for 27.9% (24 mln toe), coal – 20.8% (18 mln toe), oil products – 9.4% (8 mln toe), biomass – 4.3% (4 mln toe), hydropower plants – 0.9% (1 mln toe) and wind/solar power plants – 0.6% (1 mln toe). The total fraction of all RES is 5.8%. Optimization of the structure of the total primary energy supply aimed at decreasing the gas fraction is one of the government's permanent tasks in reforming the energy sector [3, 12].

In 2015, Ukraine established the energy generation capacity of 54.8GW including 3.2GW at the uncontrolled territories of the east and south of Ukraine. These capacities comprise 24.5 GW of thermal power plants (TPP), 6.5 GW of combined heat and power plants (CHPP), 13.8GW of nuclear power plants (NPP), 5.9GW of hydropower plants (HPP)/pumped storage plants (PSP), 0.4 GW of solar power plants (SPP) and 0.5 GW of wind power plants (WPP) [3, 13].

These capacities are mostly worn out as 50% of them are more than 40 years old. Thus, capacities supplying about 80% of current production (about 20-25GW) should be withdrawn out of operation in 2025-2040 including 11GW of 50-year-old nuclear power plants if their operation terms are doubled. Among VVER-1000 blocks, the Ukrainian blocks are some of the oldest. Plans of withdrawing them out of operation (of 50 years) may be revised after considering the practices of Nine Mile Point and Oyster Creek Nuclear Generating Stations [14]

The RES fraction in Ukraine's final energy consumption of 2015 was about 5.6% considering all national hydropower plants. This figure is three times less than the average EU-28. At the same time, about 20% of Ukraine's RES energy was produced by hydropower stations, which have been in operation for decades and located mostly on the Dnipro River. Approximately 30% of RES energy was produced from products of biological origin (solid biomass, biogas, biofuel, etc.) [15].

RES application can both enhance the energy security level and reduce the technogenic load on the environment. That is why, along with the energy efficiency increase, it can become one of Ukraine's energy policy priorities.

While considering RES, it is advisable to distinguish three basic aspects of the problem – wind and solar energy, biomass and hydropower.

As of 2016, these types of RES have the following capacities: 0.5GW of solar power plants and 0.5GW of wind power plants [15].

In 2015-2035, the structures of thermal and electric energy generation and the primary fuel consumption are expected to be changed, this resulting in 11% increase of the total supply of primary energy as compared with 2015 up to 95-98 mln toe in 2035. Yet, the index of the total primary energy supply will be lower by about 17% as compared with that of 2013 [3, 15].

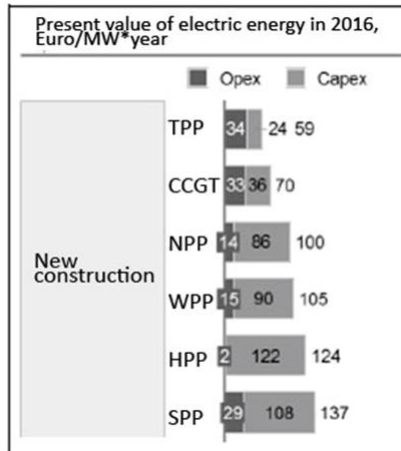

Figure 1.10 – Comparison of costs of different electric energy generation types in Ukraine

RES energy production will increase thanks to the development of Ukraine’s alternative energy after 2025. The RES fraction in the total primary energy supply is expected to increase at a fast pace from 5.7% in 2015 to 21.7% or by 3.8 times (without considering HPP/PSP – from 4.9% to 20.4%).

1.2 Features and trends of modern power industry development

Specifying SmartGrid notion with regards to electric power systems of various technical level gave rise to the emergence of such terms as StrongSmartGrid (SSG) – electric grids with the voltage over 110 kV, RegionalSmartGrid (RSG) – the voltage from 3 to 110 kV, and MicroSmartGrid (MSG) – the voltage 0.4–3 kV, typical directly for the systems themselves and arising at their integration, which determines the features of equipment construction in their connection points and in the nodes of loads connecting. The practical solution of these tasks can be performed on the basis of power electronic means and, in particular, on the basis of the

wide implementation of electrical energy parameters' converters. Power electronic means are natural elements of the systems under consideration, without them there is no question of the Smart Grid construction.

Selection of the type and structure of semiconductor converters, which are suggested for the connection of different systems, should be carried out with account for the nature of the variation of electrical energy parameters typical for one or another system. The major feature of SSG, RSG and MSG systems is an essential distinction in their electrical energy parameters variation in time. SSG systems are characterized by a relatively high stability of energy parameters [1].

In RSG systems, as a rule, some variations of the electric energy parameters take place; these variations depend on the type of connected load and the capacity of transformer substations.

Basic issues of the Smart Grid concept development in Ukraine [2]:

1. Development of strategic vision of the future power industry in Ukraine based on the concept of Smart Grid.

2. Redistribution of the basic requirements and operational properties of the domestic power engineering on the basis of the Smart Grid concept and their implementation principles.

3. Defining the major development trends for all parts of power system: generation, transmission and distribution, sales, consumption and dispatching.

4. Redistribution of the basic components, technologies, information and management solutions in all the above-mentioned spheres.

5. Ensuring coordination of modernization (aimed at overcoming the technological gap) and innovation development in the Ukrainian power industry.

Trends of electric power industry development that enjoy the priority progress [3]:

– Optimal integration of generating and storage capacities of diverse physical nature in an electric power system.

– Countering of negative impacts.

– Motivating active behaviour of the end-user. Providing access for an 'active consumer' and the distributed generation on the electric power markets.

– Ensuring the energy supply reliability and electric power quality in various price ranges.

– Transformation of the system-centric approach into customer-centric one.

– Self-healing in case of disturbances, including emergency ones.

- Asset management optimization.

Development trends for smart electric grids of the Ukraine's Unified Power System:

- Transition to the distributed generation.
- The transition from rigid dispatch scheduling and regulation to arranging coordinated operation of all network objects.
- Implementation of new technologies and power facilities that ensure manoeuvrability and controllability of an electric power system and its objects.
- Constructing of smart metering, monitoring, diagnosis and control systems covering the distributed generation as well as the electricity transmission, distribution and consumption.
- Development of a new generation of operational applications (SCADA\EMS\NMS) targeted at new power devices.
- Formation of a highly efficient integrated information and computing structure being a core of the electric power system.

Prospects for Smart Grid implementation in the Unified Power System of Ukraine

Major benefits of renewable energy sources [4]:

- cost reduction of traditional fossil fuel resources;
- reduction of Ukraine's dependence on fossil fuels importation;
- environmental compliance due to reduction of the negative impact on the environment.

Problematic aspects of the renewable energy implementation in the Unified Power System of Ukraine:

- inadequacy of Ukraine's legal framework;
- insufficient technical standards base and state standards for renewable energy power plants' design and connection to electric grids of the Ukrainian Unified Power System;
- the need to include capacities of renewable energy power plants in the daily dispatch load schedule of load on mandatory basis.

Problematic aspects of the renewable energy implementation in the Unified Power System of Ukraine:

- rapid and uncontrolled capacities increase of renewable energy power plants;
- the state-owned enterprise national electric company "UKRENERGO" does not possess a tool to restrict technical specifications issue and construction of renewable energy power plants; consequently, technical specifications for the connection of wind power farms accounting for 2062 MWe have already been issued and approved; solar power farms -

570 MWe; applications to obtain technical specifications account for about 14000 MWe, that comprises 40% of the Ukrainian Unified Power System consumption;

– reduction of cycling capacities alongside with the increase of basic capacities in the general balance of the Unified Power System of Ukraine. The need for extra spare capacity in the event of power fluctuations on solar power farms and wind power plants;

– deterioration of the quality of electricity in the power supply regions with functioning solar power plants;

– the need for extra measures aimed at reactive power neutralization and voltage regulation.

European countries experience:

1) implementation of significant capacities at renewable energy power plants (Denmark, Germany, Spain, etc.);

2) the UCTE system accident in 2006 was partially caused by significant power flows from regions with renewable energy power plants functioning;

3) the need to maintain appropriate spare capacity in the event of the power variation occurring on renewable energy power plants;

4) implementation of modern complexes to forecast the operation of renewable energy power plants, SMART GRID implementation.

1.3 Diagnostics in the life cycle of electrical equipment components

Any technical object have the following typical stages of its life cycle: design, manufacturing, operation [5].

Design – it's the process of analysis and planning of costs, lead-time, setting the requirements for electric power supply systems, product development, on the basis of which systems are created, and the operation and maintenance documentation to assure proper running of these systems.

Manufacturing – is the process of technical requirements' realization "in steel", including testing as a stage of the integrated verification of the equipment performance; the equipment being assembled from components.

Operation – is the set of technical and organizational measures that ensure technically correct application of electrical supply systems, constant availability, assuring equipment performance and their service life extension. Operation includes transportation, storage, maintenance, repair, and intended application.

Diagnostics is possible at all stages of the electric power units' life cycle (Fig. 1.11).

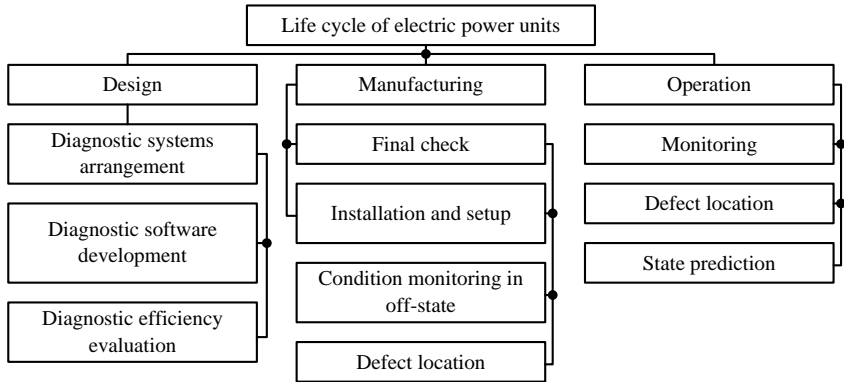

Figure 1.11 – Diagnosis in the life cycle of electric power units

At the initial stage of an electric power unit' design you need to figure out the parameters of the diagnostic system to be applied (to determine the frequency and duration of operation and diagnostics, reliability criteria, monitoring factors and components' maintainability factors). To evaluate the condition of components of the power supply units you need: firstly, to design an object adjusted for evaluation of its condition with required precision and reliability; secondly, to create technical diagnostic tools that would allow you to evaluate the object's state in the required conditions; thirdly, to determine the role and functions of the human operator involved in the diagnosis process. To make the electric power supply unit adjusted for diagnostics, while designing it you need to compile a list of evaluated diagnostic features, methods of their evaluation, conditions of performance ability and defects signs, diagnostic algorithms. In the course of designing, you determine the achievable efficiency of the diagnostic system.

While manufacturing of the electric power unit components we need to evaluate their condition. Thus, in the course of the final check the accuracy of assembly and installation are tested. In case the power supply unit' component does not comply with the given requirements, fault location is carried out.

In the course of equipment operation continuous or periodic diagnostics is performed. If necessary, fault forecasting or fault location is carried out to apply preventive maintenance or recovery work. The diagnostics at this stage can justify the further use of power supply unit

components. The diagnostics is carried out on the power supply unit in storage or the one put in diagnostic mode for this purpose.

Tasks arising from the need to perform diagnostics of power supply units on different stages can vary, which should be taken into account while developing a diagnostic system. The diversity of tasks being solved when diagnosing an object on different stages requires the development of diagnostic tools designed for use at specific stages, for example, technical means, designed for diagnosis during manufacturing or operation. The diagnostic system is efficient only in those cases when the power supply unit components condition is evaluated at all stages of its life cycle. This will increase the efficiency of the power supply unit use, while its reliability can be maintained at level provided by design.

When developing the diagnostic systems for the electrical equipment for substations and power lines of 10-220 kV and above, you need to consider the following [6]:

1. The available power transformers are characterized by a wide variety (different cooling systems, switching devices and means of lightning overvoltage protection as well as different manufacturing technologies).

2. Different level of power transformers' reliability, the complicated collection of statistical data on the reliability of large power transformers.

3. Difference in load conditions during operation.

4. Limited self-healing properties of power transformers out of factory environment.

5. Available oil circuit-breakers are not suitable for diagnostics (absence of operation counters, sensors to estimate the value of the short-circuit current the state of insulation etc.).

6. Configuration of certain instrument transformers being produced currently does not provide for their diagnosing on operating voltage.

7. The electrical switchgear equipment of substations 35-220 kV vary considerably package enclosed-type distribution substation KRPZ-10 (outdoor switchgear KRUN series KRN-3, K-6, KRN-10, switchgears series K-6, K-12, K-13, K-37, K-47, K-57), various operational lifetime and are equipped with diverse types of circuit-breakers (VMG-133, VMG-10, VK-10, VMPP-10, VMM-10), which makes difficult to carry out their diagnostics.

8. A substation use may be various: unmanned operation, house duty, duty in special room, duty cycle manning in the control room. Thus, the "human operator" link is not included in the structural scheme in the first three types of a substation use.

9. Severe difficulties occur while diagnosing the insulation of a live

power line 10-220 kV on operating voltage with the help of a measuring rods or an electro optical defect detector, since the first method is laborious, and as the second one, it is difficult to carry out measurements in clear sunny weather. According to the service conditions of an overhead power line, the breakdown of insulator string leads to the line cut-off. Thus, the task of diagnostics is to determine the initial stage of the fault and to predict the occurrence of 'zero' insulators in strings.

10. Intense environmental impact on the state of insulation.

1.4 Characteristic of the electrical equipment components' diagnostic methods

The serviceable condition of electrical equipment can be evaluated while it is functioning, observing its state (an operational diagnostics), or when it is subject to an external action, so we can observe its response (a test diagnostics) [7].

The benefit of operational diagnostics lies in the fact that its realization does not require special external sources of energy, while data is recorded and processed during its operation. Figure 1.12 shows the description of operational diagnostic methods.

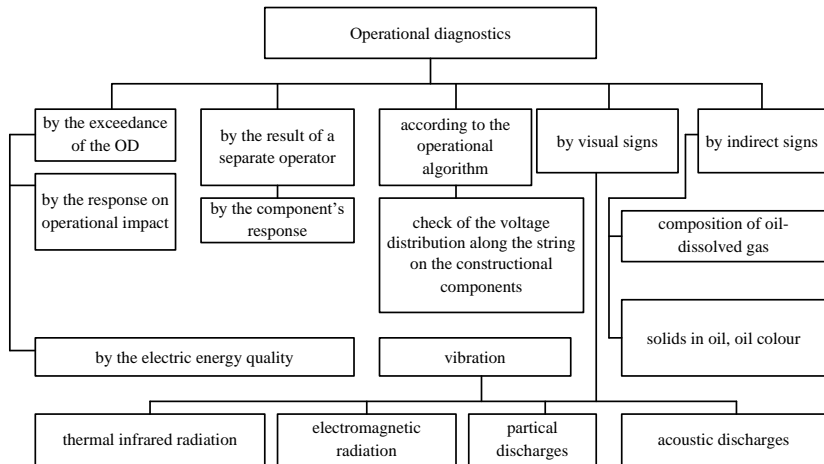

Figure 1.12 – Description of operational diagnostic methods

The state of objects in the process of their operation is evaluated by various external signs: heating of particular parts or the common thermal field, the electromagnetic field, partial and acoustic discharges, high-

frequency radiation, vibrations, and so forth, produced by the functioning object. Variation of the above mentioned parameters may indicate a variation of the condition of power supply unit components. To evaluate the condition of oil-filled equipment (transformers, reactors) during their operation, the results of oil-dissolved gas analysis are applied.

Performing a test diagnostics requires special generators that produce test actions that are applied to the electric power supply unit and stimulate its response. Figure 1.13 shows the description of test diagnostic methods [8].

Test diagnostics is performed both in active and standby state. For the test diagnostics, both working inputs (i.e. inputs for operational actions) as well as the purpose-designed inputs for diagnostics (for example, measuring leads of bushing insulators) are used.

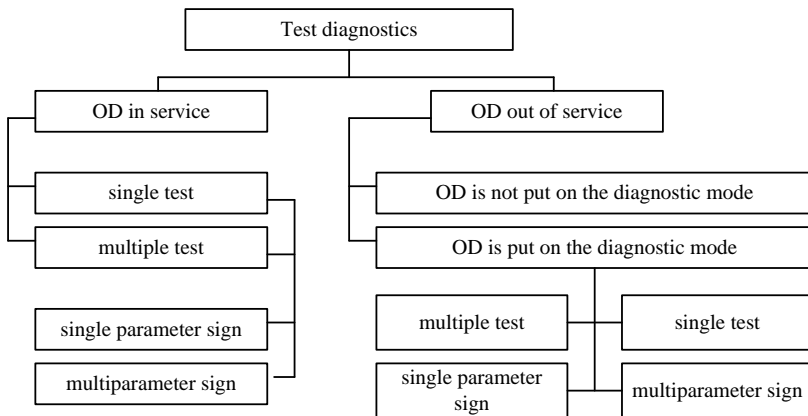

Figure 1.13 – Test diagnostic methods

This postulate also holds for recording the formation of the object response to the test action when it is diagnosed.

The test diagnostics is carried out by a single action, for example, a single pulse or a multiple action (a series of pulses), in other words, the test diagnostics is based on the results of the sum of elementary checks. In the test diagnosis, a single parameter case is possible when one index is evaluated or multiparameter one when more than one index is evaluated. The event, when one signal of an object output is evaluated by several parameters (for example, by amplitude and frequency), belongs to multiparameter cases.

For complex electric power supply units consisting of several interconnected components, a combination of various methods is applied when diagnosing various components. In this respect, operational as well as

test diagnostics is allowed to be performed on the same electric power supply unit [9].

1.5 Defect symptoms and their detection methods

A defect presence indicates that undesirable changes occurred in the functioning of the object of diagnostics; these changes led to its performance impairment or a reduction of the degree of its performance ability. The object's failure is the simplest type of defect symptom. Failure of the object of diagnostics means that either the entire object or its part does not function and, consequently, does not show 'vital signs'. Thus, the absence of voltage on a switchboard of an electric power plant signifies its complete failure.

Mathematically, the sign of a defect occurrence can be represented as follows [10]:

– performance impairment according to parameters $|\xi_{in} - \xi_i| \geq \Delta_i$;
 according to characteristics $|f(x) - \varphi(x)| \geq \Delta$;

– drop of the degree of its performance ability, that is transition from the state s_i in the state s_j in the field of performance $S_p: s_i \rightarrow s_j \in S_p$;

– failure of one of the structural units of the complex object that involves transition of the object under diagnostics from serviceable conditions $S_p = (1, 1, \dots, 1)$ to nonserviceable ones $S_H = (0, 1, 1, \dots, 1)$;

All methods of defects detection can be divided into three groups: inspection, detection and location. If it is known that the object of diagnostics failed, you first need to carry out a visual inspection of the power supply unit' electrical elements. Thus, you can detect contact couplings fault, wire breakages, insulators destruction, etc.

Automated detection is now being used for various objects of diagnostics. In this case, a number of sensors are placed in the object depending on the required precision of fault location, which alarm the fault occurrence. Such sensors may include thermocouples, temperature responsive switches, short circuit currents recorders and other elements responsive to overvoltage and overcurrents.

In objects that may be represented as systems with sequential data processing (Fig. 1.11), an occurred defect can be found by detection of the signal transmission.

The fault location is carried out by developing the conclusions, which lay in the continuous narrowing of the search area of a defect location, making logical decisions and performing rational verifications. Such an approach reduces the number of verifications, which not only saves time, but

also minimizes the probability of errors. To select the sequence of inspections, you need to know how certain defects affect the state of the object under diagnostics. There are two ways to achieve this goal:

- 1) simulation of faults;
- 2) analysis of the diagnostic model of the object under diagnostics.

The fault simulation is widely used for various diagnostic objects.

The outcome of the experiment are summarized in the table (Table 1.2).

Table 1.2 – Table of faults

Fault	Transient characteristic type $h(t)$
Short circuit R_i	
Discontinuity C_i	
Reduction of the amplification factor	

As a result of the diagnostic model analysis, one can develop recommendations concerning fault location by ranging the diagnostic features in accordance with their effect on the condition of the object under diagnostics; for example, by calculating the sensitivity of the transmission function T_{ijk} to the variation of the analysed diagnostic parameters r_k , provided the object assumed by the model in the form of a graph or a diagram of the type (Fig. 1.14) signals transmission [11].

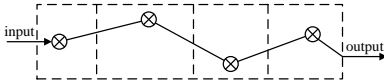

Figure 1.14 – Indicating circuit of signal transmission in the object

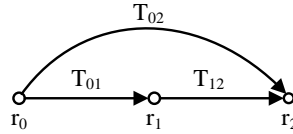

Figure 1.15 – Signal transmission diagram

The transmission function sensitivity can be determined with the help of the expression:

$$S_{r_\alpha}^{r_{ij}} = \frac{\partial T_{ij}}{\partial r_\alpha}, \quad (1.1)$$

where T_{ij} – transmission functions from i -th input to j -th output; r_α – variable parameter, $\alpha = \overline{1, l}$ ($\alpha = 0$ – input parameter, it should be constant).

1.6 Defect location algorithm

The task of the occurred fault location in contrast to the task of performance monitoring typically requires a longer analysis of the object under diagnostics or its model. In this respect, the level of detail is determined by the specified precision of fault location, that is, indicating the part of the object (structural unit) that defines the precision of the search of the fault area. Thus, if the precision of fault location is specified, the object of diagnostics can be represented by the multitude having N interrelated parts – structural units (SU) [11].

The location of a fault or a condition of the object is performed by an algorithm that includes a certain set of verifications. A *verification* is called an evaluation of the structural unit condition according to its or the entire object's output parameters. Thereby, the multitude of conditions in general case is bigger than the number of verifications, since during a single verification more that one fault can be located. Each verification requires some expenses. While developing the fault location algorithm, we try to select such a sequence of verifications that allows us to locate a fault at the lowest cost.

Function (structure) charts can be used to develop fault location algorithms. The term "function" here means that the block performs a certain function. Blocks are interconnected in the way that particular functions are performed in a certain sequence, realizing the task designated to this particular equipment unit or the system according to its destination.

A function chart is a graphical representation of blocks it comprises and corresponding signal paths. We should bear in mind that the arrangement of function blocks on the chart doesn't correspond to their actual physical location in the equipment configuration.

In the electric circuit diagrams signals pass through signal circuits of two types: series and branched ones. A series circuit scheme (fig. 1.16) includes the group of circuits (cascades) connected in such a manner that the output of one circuit is connected to the input of another one.

As a result, the signal passes directly through the group of circuits without being transmitted in the reverse direction and without branching.

A branched circuit scheme can be of two types: divergent and convergent. In the divergent circuit scheme (Fig. 1.17, a) two or more signal circuits are connected to the output end of an element. If two or more signal circuits are connected to the input end of the element, it is called a convergent circuit scheme (Fig. 1.17, b). In this case, during the first verification you should try to determine the circuit where the fault has occurred. It allows you to exclude one of the signal circuits that is in good operating condition [12].

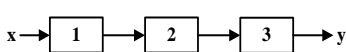

Figure 1.16 – Series signal circuit

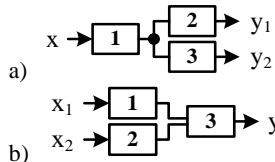

Figure 1.17 – Branched signal circuit
a) divergent; b) convergent

In view of the fact that present-day electrical automation systems comprise hundreds of components, testing each component in order to locate a defect is significantly time-consuming. The scope of search can be reduced several times, provided that not every component is tested, only the output signal of each circuit (cascade). However, to carry out this number of checks is also quite laborious. Having split the analyzed schemes into structural units (they can amount to several dozens), we can reduce the number of verifications, bringing them to the acceptable level.

Since each verification divide the space of states in two parts (that includes and does not include the target state), the performance of a verifications sequence results in the location of a certain state that corresponds to the detection of a failed SU. A sequence of checks performed to locate a fault can be represented as a graph (a tree), where the treetops signify checks, the branches indicate the direction of transition based on the test result, and the end tops are detected faults.

The first check being completed, the question arises: 'What to do next?'. The answer depends on the results of the first check. The only two outcomes are possible: adequate (+) and inadequate (-) performance of the structural unit under test. In the latter case the SU is either completely out of order or operates with degraded performance. In any case, the result will show what kind of the following verification is required.

Fault search algorithms can be of three types: sequential, parallel and combined.

In the *sequential search* each verification points out one defect in the search space. This condition can be met for an object of diagnostics represented in the form of a series circuit of structural units, when it is known that the signal is applied to the input, and we can determine the fault presence in the object of diagnostics by the output signal in two ways: from the beginning to the end and from the end to the beginning. Let's exemplify the fault location algorithm with the help of the object of diagnostics (Fig.1.18, a).

In the first case, we need to perform a check at A point, since it will allow us to immediately exclude from consideration one element SU – 1. If the signal is within the allowable limits, the verification should be performed at B point, which will enable us to determine the state of SU – 2. If the result of the check is negative, it means that the defect is in this element. If it is positive, we need to carry out the check at C point [13].

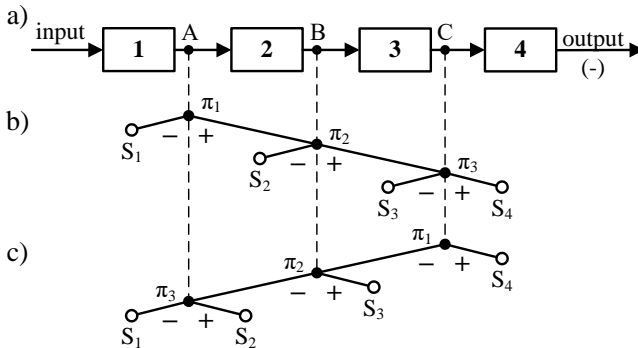

Figure 1.18 – Fault location algorithm

If the result of the check is positive, the defect is in SU 4, otherwise – the defect is in SU 3. The location (search) algorithm is shown on the Fig. 1.18, b.

In other case (from the end to the beginning), if the result of the check in C point is negative, this check is to be performed in B point. If the check result is positive – in SU 3; if the result is negative, the check is performed. According to this check’ results we located the defect either in SU1 or SU 2 (Fig.1.18, c) [14].

The number of checks N to detect all defects in the object of diagnostics (OD) is determined by the relation $N = n - I$; n – the number of the object SU.

In *parallel search* each check splits the OD in two equal or nearly equal parts, if the OD consists of even or odd number of SUs respectively.

Thus, in case of the parallel search performed for the OD comprising four SUs (Fig.1.19, a), the first check is carried out in B point. If the result is negative, the following check is carried out in A point, thus determining the location of the defect (SU 1 or SU 2). Otherwise, the check is performed in C point, that allows us to determine the defect in SU 3 or SU 4. The search algorithm is shown on the Fig. 1.19, b.

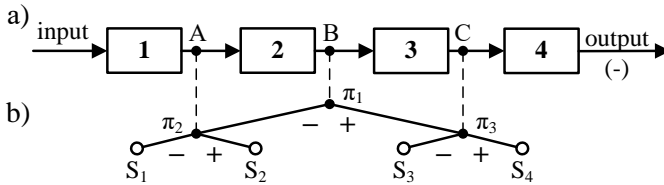

Figure 1.19 – Defect location algorithm

The number of checks N , required to locate all defects by the number of SU can be calculated using the formula:

$$N = [\log_2 n] - \text{integral part.}$$

For $n = 4$ two checks are required, for $n = 8$ – three checks.

In *combined search* involves a combination of sequential and parallel algorithms.

Applying the tree-type fault location algorithm, we can determine the total length of the branches to reach the sought defect [15].

$$L_i = \sum_{j=1}^p l_{ij} \tag{1.2}$$

where l_{ij} – the length of i -th branch, p – the number of branches from the beginning of search till the sought defect is reached. For example, for the graph presented in Fig.1.19, b):

$$L_i = \sum_{j=1}^2 l_{ij}$$

If l_{ij} is considered as time, than, using the formula for L_i , we can define the time being spent for location of i -th defect.

$$\tau_{ni} = \sum_{j=1}^p \tau_{ij} \quad (1.3)$$

Defect/fault location algorithms can be developed on the basis of the analysis of the object structure or use of indexes that characterise the reliability of SU.

1.7 Diagnostic parameters forecasting

Analytical prediction

Extrapolation methods applied to determine the value of a predicted variable are called *analytical* or *analytical prediction methods*.

When choosing a mathematical apparatus to solve the problem of analytical prediction, we need to pre-determine the diagnostic parameters. From the technical point of view it is complicated to estimate the parameters of each component constituting the object due to their large number, therefore, we try to select a minimum number (one to two) of the diagnostic parameters that ensure the required predictability of the object state variation [16].

The chosen parameters should be sensitive to variations occurring in the components composing the object of diagnostics, that is, any trend of condition of the constituent elements should be reflected in the behaviour of the selected diagnostic parameter. Particularly, such parameters can be transmission factor, amplification factor (gain), feedback parameters, etc.

Let's consider setting up a prediction problem. For the sake of simplicity we will assume, that the performance ability of the object is determined by one parameter ξ . In this case the forecasting of the object performance is considered as a prediction of a variation of the function $\xi(t)$, the value of which varies discretely or continuously in the time interval $T_I = [t_o, t_n]$. This results in this function values $\xi_o, \xi_1, \dots, \xi_i, \dots, \xi_n$ on the interval T_I (Fig.1.20) [17].

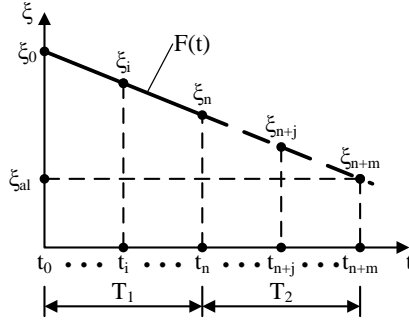

Figure 1.20 – Diagnostic parameter variation

We need to use the known values ξ_i to determine the value of the function $\xi(t)$: $\xi_{n+1}, \xi_{n+i}, \dots, \xi_i, \dots, \xi_{n+m}$ in the future points of time $t_{n+1}, \dots, t_{n+i}, \dots, t_{n+m} \in T_2$ or to find out in how much time the values ξ_{n+i} , $t_{n+i} \in T_2$ attain the acceptable level ξ_{don} . The problem can be solved by the polynomial extrapolation method and the regression analysis.

Polynomial extrapolation method. The ideal case of the solution to this problem is an adequate description of a variation of the function $\xi(t)$ with a certain analytic expression. Since it's quite complicated to find such expressions by discrete points ξ_i it is worthwhile to determine the best structure of the analytic expression, and when predicting a specific function $\xi(t)$ – to change basic elements constituting this expression [18].

In the interval T_1 by known values ξ_i we need to find such a function $F(t)$, which would describe the variation of the state of the object of diagnostics with the given accuracy, that is to perform interpolation. In general case, we can use the polynomial of the form:

$$F(t) = \sum_{l=0}^r a_l \varphi_l(t) \quad (1.4)$$

where a_l – unknown coefficients; $\varphi_l(t)$ – known simplest functions.

Obtaining polynomial $F(t)$ is to determine the coefficients a_l . It is worthwhile to use as functions $\varphi_l(t)$ the functions with the simplest structure, for example:

$$\varphi_0(t) = 1; \varphi_1(t) = t; \varphi_2(t) = t^2; \dots; \varphi_r(t) = t^r.$$

Therefore, we have a basic polynomial in the form:

$$F(t)=a_0+a_1t+a_2t^2+\dots+a_r t^r, \quad (1.5)$$

A graphic illustration of its certain parts is shown in Fig. 1.22.

Many power expressions may that vary in the way of calculating a_l can be converted in this form.

For example, as a result of measuring the parameter ξ in the points of time t_0 and t_l its values obtained are ξ_0 and ξ_1 (fig.1.22).

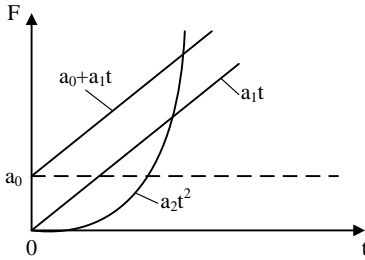

Figure 1.21 – Simple polynomials

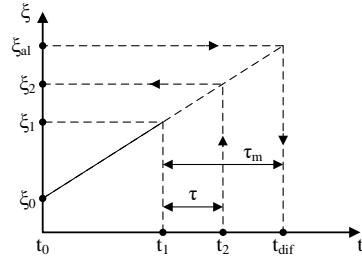

Figure 1.22 – Diagnostic parameter variation

Interrelation $(\xi_1 - \xi_0)/(t_1 - t_0) = \dot{\xi}$ will be referred to as a mean rate of the parameter variation in the interval $[t_0, t_l]$. We can describe the character of the parameter variation in this time interval using the expression:

$$F(t)=a_0+a_1t, \text{ where } a_0=\xi_0; a_1=\dot{\xi}.$$

Assuming that the parameter variation rate is kept, you can predict the value of the parameter in time τ .

In practice, for small intervals τ such a forecast is quite acceptable.

If the acceptable value of the diagnostic parameter is known ξ_{don} , then using this formula we can define *the residual operation time*, that is the time of possible equipment operation till failure:

$$\tau_{r.o.} = (\xi_{al} - \xi_1) / \dot{\xi}. \quad (1.6)$$

Knowing the residual operation time of equipment for each parameter, we can determine the overall time of its good performance that equals to the smallest residual operation time for all diagnostic parameters.

To make the precise prediction we should apply more complex extrapolation formula and use the results of more that two measurements.

While forecasting the state variation by one generalized parameter, Lagrange and Newton polynomials can be used for extrapolation [18].

The general form of the Lagrange polynomial can be represented in the following way:

$$F_L(t) = \sum_{i=0}^r L_i \xi_i^{\xi}, \quad (1.7)$$

where ξ_i^{ξ} – the value of the diagnostic parameter in the points of time t_i ; L_i – Lagrange coefficients.

In the simplest cases:

$$l=1: F_L(t) = \frac{(t-t_1)}{(t_0-t_1)} \xi_0^{\xi} + \frac{(t-t_0)}{(t_1-t_0)} \xi_1^{\xi};$$

$$l=2: F_L(t) = \frac{(t-t_1)(t-t_2)}{(t_0-t_1)(t_0-t_2)} \xi_0^{\xi} + \frac{(t-t_0)(t-t_1)}{(t_1-t_0)(t_1-t_2)} \xi_1^{\xi} + \frac{(t-t_0)(t-t_1)}{(t_2-t_0)(t_2-t_1)} \xi_2^{\xi}.$$

Taking into consideration, that the coefficients of polynomials applied for extrapolation are independent of the value of the predicted parameter, that can be calculated in advance and summarized in the special tables that simplifies the process of forecasting.

The Newton polynomial is widely applied in forecasting.

$$F_N(t) = \xi_n + \Delta \xi_{n-1} (t-t_n) + \frac{\Delta^2 \xi_{n-2}}{2!} (t-t_n)(t-t_{n-1}) + \dots + \frac{\Delta^r \xi_0}{n!} (t-t_n)(t-t_1), \quad (1.8)$$

where $\Delta \xi^{\xi}$ – is the first difference between the measured values;

$\Delta^2 \xi^{\xi}$ – the second difference (difference of the differences) etc.

The polynomial of the first order $r = 1$, applied for extrapolation, is as follows:

$$F_N(t) = \xi_n + \Delta \xi_{n-1} (t-t_n), \quad (1.9)$$

and the polynomial of the second degree $r = 2$, respectively:

$$F_N(t) = \xi_n + \Delta \xi_{n-1} (t-t_n) + \frac{\Delta^2 \xi_{n-2}}{2!} (t-t_n)(t-t_{n-1}), \quad (1.10)$$

where t is obtained form the area T_2 (the differences $t-t_n$ and $t-t_{n-1}$ can be expressed by the number of prediction steps $m = \Delta t$ respectively $m+1$ and m).

Since, in this case, the coefficients at the finite differences do not depend on the predicted function, they can be calculated in advance and summarized in the table. The tables of coefficients of polynomials applied for extrapolation considerably simplifies the process of forecasting, since they reduce the amount of computation required and facilitate forecasting automation.

In actual practice we confine ourselves to first and second order polynomials, since the rate of state variation does not exceed the rate of response of polynomials. The actual processes progress quite slowly. In this case the parameters variation curves, which characterize the state of the object under diagnostics, are fit between the lines that represent the polynomials of the first (AB) and the second (AC) degree (Fig.1.23).

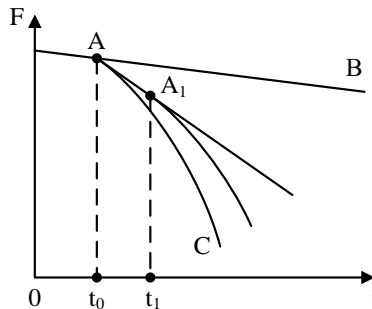

Figure 1.23 – Forecast accuracy improvement

The forecasting accuracy can be improved, if the prediction is carried out at one step only with subsequent inclusion of the obtained value (point A_1) in the area of the known values T_1 . By doing so each prediction (at one step) starts with a new point A_1 , obtained by the process shift at one step (t_0, t_1).

The number of measurements and forecasting time have an impact on the forecast accuracy: the more n is, the more accurate will be the forecast, since we manage to describe with greater precision (to interpolate) the process of a parameter variation in the area T_1 . The longer the time period of forecast T_{mean} is, the less will be its accuracy, since not all the factors can be taken into consideration in the area T_2 . The minimum number of required measurements is related to the degree r of polynomial in the following way:

$$n = r + 1.$$

In real case scenario, in order to obtain an acceptable forecasting accuracy n is 3–5 times multiplied [18].

Thus, the use of polynomials for extrapolation while performing analytical (deterministic) prediction involves:

- 1) selection of the optimal expression $F(t)$ taking into consideration the trend of parameter variation in the area T_1 ;
- 2) defining coefficients α_i to obtain the accurate forecast;
- 3) extrapolation of $F(t)$ on the area T_2 and determining the parameter value in the required (prognosticated) point of time;
- 4) evaluation of the forecast accuracy.

Regression analysis method. It is based on the application of the regression equation (Lat. regressio – backward motion) that has the form:

$$y = \beta_0 + \sum_{i=1}^k \beta_i x_i + \varepsilon, \quad (1.11)$$

where y – the value, whose nature of variation is to be determined;
 β_0 – constant value; β_i – coefficients; x_i – parameters, influencing the predicted value; Σ – weighted sum; ε – random error.

It is a linear dependence of y on x .

The model of the diagnostic parameter variation ξ in time based on the regression equation takes the following form:

$$\xi = \xi_0 + t / a, \quad (1.12)$$

where ξ_0 – initial value of the parameter; a – regression coefficient, which determines the slope of a line.

Obviously, the OD performance time to failure t_{dif} will be defined by the acceptable value of the diagnostic parameter:

$$t_{dif} = (\xi_{al} - \xi_0) a. \quad (1.13)$$

The electrical equipment, however, comprise objects (electric machines windings) for which this value is impossible to be set. What can be done in this case?

Let's consider the equivalent circuit of an electric machine winding (Fig.1.24). Here Rg – resistance of the known value. For the case under consideration the forecast is primarily aimed at determining the residual operation time. The diagnostic parameters are $\Xi = (L, R_l, C_l)$, where L – equivalent inductance of winding; R_l – equivalent resistance of winding; C_l – equivalent capacitance of winding.

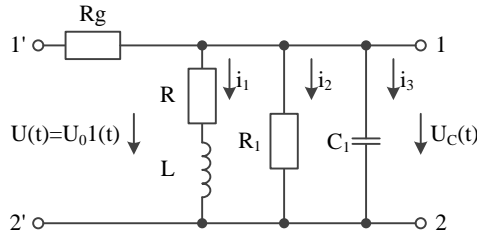

Figure 1.24 – Equivalent circuit of an electric machine winding

Due to the fact that the inductance changes in a step-like manner with the occurrence of shorted turns, this parameter is not suitable for the forecasting problem. The diagnostic parameters R_I and C_I characterize the state of insulation, which is subject to ageing and changes monotonically. This problem is quite difficult to solve, since acceptable values of parameters R_I and C_I of the electric machine winding are unknown.

The source data for forecasting will be values of diagnostic parameters R_I and C_{I_2} in general case ξ_{ij} for N machines in the points of time t_j , where $i = \overline{1, N}$; $j = \overline{1, n_i}$. The value for each object is computed using the method of regression analysis according to the measured parameters [11]:

$$a_i = \frac{n_i \sum_{j=1}^{n_i} t_j^2 - \left(\sum_{j=1}^{n_i} t_j \right)^2}{n_i \sum_{j=1}^{n_i} \xi_{ij} t_j - \sum_{j=1}^{n_i} \xi_{ij} \sum_{j=1}^{n_i} t_j}; \quad (1.14)$$

$$\xi_{oi} = \frac{1}{n_i} \sum_{j=1}^{n_i} \xi_{ij} - \frac{1}{n_i} \sum_{j=1}^{n_i} \frac{t_j}{a_i}. \quad (1.15)$$

To forecast residual operation time of the electric machine windings, we need to determine the acceptable value of diagnostic parameters R_{Ial} and C_{Ial} , that is ξ_{at} . To do this, mean values for linear regression are calculated:

$$a = \frac{1}{N} \sum_{i=1}^N a_i; \quad \xi_0 = \frac{1}{N} \sum_{i=1}^N \xi_{oi}$$

Applying (1.12), we can perform forecasting.

In some cases, for example, winding insulation resistance of electric machines, it is impossible to set an acceptable parameter value. In this case it can be defined in the following way.

Basing on the collected statistic data we define the mathematical expectation of the failure time:

$$M(t_{dif}) = (\xi_{al} - \xi_0)a, \quad (1.16)$$

whence we get

$$\xi_{al} = \xi_0 + M(t_{dif}) / a. \quad (1.17)$$

This value is taken as the acceptable boundary value of the diagnostic parameter.

Then for the i -th electric machine the failure time can be predicted, having applied the formula:

$$t_{dif} = (\xi_{al} - \xi_{oi})a_i = [\xi_0 + M(t_{dif}) / a - \xi_{oi}]a_i. \quad (1.18)$$

Let's find the time of failure-free operation from the moment of the end of observations. The difference $\delta_0 = \xi_{al} - \xi_0$ – good operation time, $\delta_0 = \xi_{al} - \xi_1$ – residual operation time. Using the formula of linear model of diagnostic parameters variation, we find the residual operation time $\tau_{r.o.i}$ for the i -th electric machine:

$$\tau_{r.o.i} = (\xi_{al} - \xi_1)a_i = [\xi_0 + M(t_{dif}) / a - \xi_{oi}]a_i. \quad (1.19)$$

To solve this task we can take previously collected information on the variation of diagnostic parameters of the electric machine in operation. Such dependences R_I and C_I for two electric machines are shown in the Fig. 1.15.

Thus, the method involves [18]:

- 1) selection of the monotypic OD being operated in equal conditions;
- 2) measuring of diagnostic parameters values ξ_{ij} for the entire set of ODs in certain time intervals t_j ;
- 3) computation of the mean values $\bar{\xi}(t_j)$ of all ODs for the fixed point of time t_j ;
- 4) defining the regression coefficient a by the parameters values in points of time t_j ;
- 5) defining mean time of failure-free operation T_{mean} ;
- 6) computation of allowable value ξ_{al} ;
- 7) defining the residual operation time.

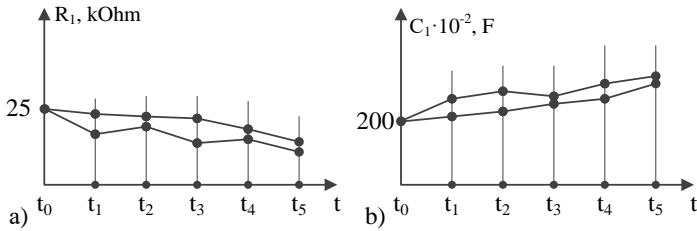
 Figure1.25 – Variation of parameters R_1 and C_1

The considered method can be used to evaluate the state of various electrical equipment: electric machines, cables, transformers, converters, secondary cells, etc.

The obvious drawback of trend calculations with the help of linear regression is the assumed hypothesis of its linearity, since in actual practice the diagnostic parameters can vary exponentially due to wearing or be saturated.

Probabilistic forecasting

The tasks of probabilistic forecasting resolve themselves into defining the probability of the predictable process overrunning (not overrunning) the set limits.

Thus, mathematical problems of the probabilistic forecasting are formulated in the following way. The values of the time function (diagnostic parameter) $\xi(t)$ are known in points of time t_i , $i = \overline{1, n}$; $t_i \in T_1$. We need to determine the probability that the value of function $\xi(t)$ does not fall outside the acceptable limits ξ_{al} in the points of time t_{n+j} , $j = \overline{1, m}$, $t_{n+j} \in T_2$, that is $P\{\xi_{n+j} > \xi_{al}\}$ [10].

It's quite easy to determine the probability, if we know the probability distribution law for the diagnostic parameter:

$$P\{\xi_{n+j} > \xi_{al}\} = \int_{\xi_{al}}^{\infty} f_{n+j}(\xi) d\xi \quad (1.20)$$

where $f_{n+j}(\xi)$ – probability density function of the value ξ in the time intersection t_{n+j} with expected mean $m_{n+j}(\xi)$ and dispersion $\sigma_{n+j}^2(\xi)$.

The distribution function $F(\xi)$ of the random value ξ in the time intersection t_i is related to the probability density function $f(\xi)$ by the following relation:

$$f(\xi) = dF(\xi)/d\xi; \quad F(\xi) = \int_{-\infty}^{\xi} f(\xi)d\xi$$

In practice, the values of diagnostic parameters are usually distributed in accordance with the normal law:

$$f(\xi) = \frac{1}{\sigma_{\xi}\sqrt{2\pi}} \exp\left(-\frac{(\xi - m_{\xi})^2}{2\sigma_{\xi}^2}\right), \quad (1.21)$$

where m_{ξ} – expected mean; σ_{ξ} – root-mean-square deviation (characterises values scattering with respect to the expected mean); $\sigma_{\xi}^2 = D$ – dispersion.

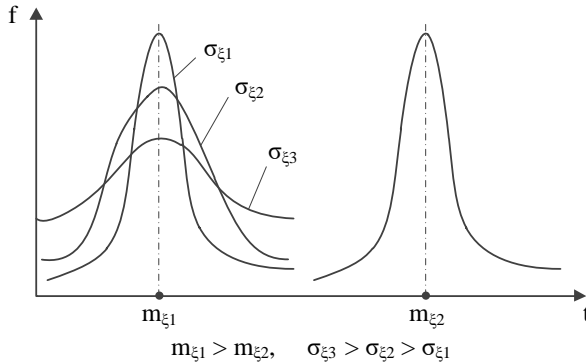

Figure 1.26 – Normal law of distribution

Those values are considered in the following way:

$$m_{\xi} = \frac{1}{n} \sum_{i=1}^n \xi_i; \quad \sigma_{\xi} = \sqrt{\frac{1}{n-1} \sum_{i=1}^n (\xi_i - m_{\xi})^2}$$

If the probability distribution law is normal, the probabilistic forecasting can be narrowed down to the forecasting of the variation of an expected mean.

The illustration of formulation and solution of the probabilistic forecasting problem using statistic extrapolation is shown in Fig. 1.27.

Whereas one must [18]:

- define on the interval T_I m_{ξ} and σ_{ξ} for each time intersection;
- carry out interpolation of the values m_{ξ} and obtain the polynomial $F(t)$;
- carry out extrapolation m_{ξ} and σ_{ξ} in the required time t_{n+j} ;

– calculate the probability of the diagnostic parameter falling/not falling outside the acceptable limits.

In order to ensure the required prediction accuracy while performing the probabilistic forecasting for each time intersection, we need to determine the probability distribution law of the parameter values; therefore, we need a sample consisting of about 30-50 monotypical ODs. The amount of the time intersections considered to interpolate the nature of parameter variation is selected in the same way as for deterministic forecasting.

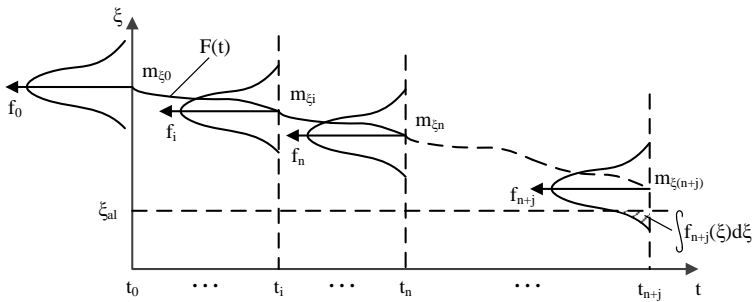

Figure 1.27 – Probabilistic forecasting

Forecasting applying the statistical classification method

The statistical classification is based on the theory of pattern recognition. Pattern recognition implies the attribution of the phenomenon or the object under consideration by their image to one of the known classes of objects or phenomena. The assumption is that each class is characterized in a certain way, inherent in each image from the multitude of images composing this class.

It requires the solution of two problems. *Classes formation*, often being interpreted as *learning*, in which the *similarity measure* is determined on the basis of the study of each class images, or a *class description* is provided, and the actual *recognition*, in which the *similarity measure* of the image’s class is determined as well.

On the basis of the results obtained, we decide to attribute images to the class, to which the OD similarity measure is maximal.

A certain class membership of an image is characterised by the *similarity function*, with the help of which the probability of this class membership is determined. It should be noted that the attribution of an image to a certain class can be based, in fact, not on similarity (proximity), but on the differences between classes.

Solving the OD forecasting problem, we consider the *classes* are considered $R^\gamma, \gamma = \overline{1, m}$, which are divided into (Fig.1.28):

$$\text{parametric ones } R_\xi^\gamma: R_\xi^1 = \xi_0 \dots \xi_1, R_\xi^{21} = \xi_1 \dots \xi_2, \dots, R_\xi^m = \xi_{m-1} \dots \xi_m,$$

where $\xi_i \dots \xi_j$ – the interval in the tolerance zone;

$$\text{time ones } R_T^\gamma: R_T^1 = T_0 \dots T_1, R_T^2 = T_1 \dots T_2, \dots, R_T^m = T_{m-1} \dots T_m,$$

where $T_i \dots T_j$ – is the time interval.

A class multitude and magnitude are determined by the OD specific features. They unite objects that have identical parameters of their state, a set of properties, etc. Each time class characterizes the operating life, and parametric one - the performance margin.

Classes R^γ present certain standards (prototypes, portraits). They are set on the basis of tests. In doing so, we determine the extrapolation links F^γ , that connect the diagnostic parameters values with classes.

The classes are to be separated from each other. If the classes vary significantly, it is easy to find the boundary; if they overlap, it becomes complicated. The state is recognizable at the boundary. The classes boundaries (Fig. 1.29) can be set by the method of zones, applying the following rule for its solution:

$$d_s = \begin{cases} -1, & \text{if } \xi \leq \xi_1^L; \\ 0, & \text{if } \xi_1^L < \xi < \xi_1^U; \\ +1, & \text{if } \xi \geq \xi_1^U. \end{cases} \quad (1.22)$$

The larger the zone '0' is, the more reliable the recognition is.

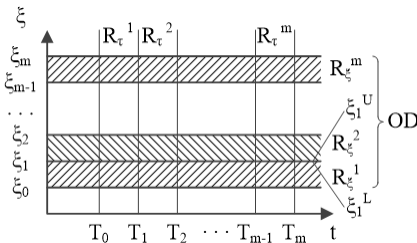

Figure 1.28 – Parametric and time classes

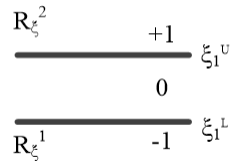

Figure 1.29 – Class boundary

If the object's state is evaluated by n parameters, the proximity measure is calculated as a sum:

$$d_\Sigma = \sum_{i=1}^n d_i \quad (1.23)$$

For example (see. Fig.1.19), if $d < 0$, that the OD is attributed to the class R^1 , if $d > 0$, in it attributed to the class R^2 . If $d = 0$, the OD cannot be classified with the help of this method [18].

The forecasting problem while using the statistical classification method (objects recognition) is formulated in the following way.

The object state is characterized by the set $\Xi = \{\xi_i\}$ having m diagnostic parameters: ξ_j , $j = \overline{1, m}$ (in the simplest case – one). We know the values ξ_i in the point of time t_o or in the limited time interval $[t_o, t_l]$. We need to make a decision concerning the object membership, according to its state, in one of the known classes R^r .

Such a statement of a forecasting problem assumes that each set $\Xi = (\xi_{j1}, \xi_{j2}, \dots, \xi_{jn})$ of diagnostic parameters values ξ_{ji} , $i = \overline{1, n}$, that characterizes a certain class of states has a corresponding durability or a degree of performance ability of an object.

The forecasting procedure involving the methods of statistical classification implies:

- 1) determining the initial sample of N objects with guaranteed operational period T_o . Each object of the sample N has a certain corresponding operational period t_i , $i = \overline{1, N}$;
- 2) based on the relation of values T_o and t_i objects are divided into classes;
- 3) the description of each object of diagnostics with m -dimensional state vector;
- 4) selection or construction of the recognition function F^r or the decision rule d ;
- 5) the actual recognition, i.e. the object's attribution to a certain class according to its state.

As it was stated above, the first two actions belong to learning problems' solving, that is why they are often called the *learning* stage, and the latter three ones correspond to the *recognition* stage, and they are called *basic*.

Thus, if the object's state is characterized by a state vector:

$$\Xi = (\xi_1, \xi_2, \dots, \xi_m),$$

Then during the learning we receive vectors Ξ^r forming the classes R^r .

It means that performing probabilistic or statistical processing of vectors $\Xi \in R^1, \Xi \in R^2$, within each class R^{γ} we can describe a state with the help of a distribution density function $f^1(\Xi), f^2(\Xi)$.

Depending on the manner the class is described or what the the setting up of the problem requires, the classification of vectors is performed by deterministic or probabilistic methods.

While applying deterministic methods, we use distances as the proximity measure:

$$d^1 = \Xi_s^1 - \Xi_i, \quad d^2 = \Xi_s^2 - \Xi_i, \dots,$$

where Ξ_s – the reference value of the parameter of γ -th class.

Minimum distance d_{\min}^{γ} indicates the object's membership in the class R^{γ} .

Probabilistic methods assume computation of the probabilities values $P^1(\Xi_i \in R^1), P^2(\Xi_i \in R^2), \dots$. Maximum probability value P_{\max}^{γ} indicates the object's membership in the class R^{γ} .

Thereby the following is required [18]:

- learning, that is obtaining a range of statistical data by values $\xi(t)$
- development of the discriminant function, i.e. an equation of surface, which divides classes R^{γ} in space.

For classes formation during the learning we need to have several hundred measured values of diagnostic parameters. The forecasting by statistical classification methods is mainly applied in series production, where a considerable “learning” sample is available.

List of references for chapter 1

1. Kalyabin VP, Rybakov L. M. Reliability and diagnostics of electric power units: Study guide. /Mari State University – Yoshkar-Ola: 2000. – 357 pp.: ill.
2. Gouk Yu. B. Reliability analysis of electric power units. – Leningrad: Energoatomizdat Publ., 1989. – 244 pp. ill. – (Reliability and Quality).
3. Gulyaev V. A., Konstandy G. G. Technical diagnostics. Methods for determination of the frequency of electric power systems diagnosing. – Kiev: Engineering, 1987. – 200 c.
4. Kalyabin V. P., Mozgalevsky A. V., Galka V. L. Reliability and technical diagnostics of shipboard electrical equipment and automatic equipment: Manual. – St. Petersburg: Elmore, 1996. – 296 c.
5. Rozanov M. N. Reliability of electric power systems. 2-nd Rev. and Ext.Ed. – Moscow: Energoatomizdat Publ., 1984. – 200 c.

6. Rybakov L. M., Khalilov F. K. Improving operational reliability of transformers and high voltage electric motors. – Irkutsk: Irkutsk University Publishers, 1991. – 155 c.
7. Svi P. M. Methods and means of the high voltage equipment diagnostics. – Moscow: Energoatomizdat Publ., 1992. – 239 c.
8. Ushakov V. Ya. Insulation deterioration and methods of its condition monitoring. Study guide. – Tomsk: Tomsk Polytechnic University Publishers, 1993. – 368 c.
9. Fokin Yu. A. Reliability and efficiency of electric power grids. Moscow: Higher School Publishers, 1989. – 151 c.
10. Sinchuk O. M., Sinchuk I. O., Boyko S. M., Karamanets F. I., Yalova O. M., Parkhomenko R. O. Renewable electric energy sources in the structure of power supply systems of iron ore mining enterprises. (Analysis, prospects, projects): monograph. Kryvyi Rih: PE Shcherbatykh O. V. Publishing House, 2017. 152 pp.
11. World Energy Outlook –2015, OECD/IEA, Paris.
12. Ukraine’s Power Industry Strategy for the period till 2035. // The Ministry of Energy and Coal Industry of Ukraine website: [electronic source]: <http://mpe.kmu.gov.ua>.
13. Skalkyn F. V. Energy and Environment / F. V. Skalkyn, A. A. Kanayev, I. Z. Kopp. – Leningrad: Energoizdat Publ., 1981. – 280 pp.
14. World Energy Resources; in P. S. Neporozhnyi, V. I. Popkov (Eds.) – Moscow: Energoatomizdat Publ., 1995. – 232 pp.
15. Basic parameters of the national economy energy supply of for the period until 2020. Stogniy B. S., Kyrylenko O. V., Prakhovnik A. V., Denisyuk S.P., Nehoduiko V. O., Pertko P. P., Blinov I. V. – Kyiv: Publ. Institute of Electrodynamics of the National Academy of Sciences of Ukraine, 2011. – 275 pp.
16. Smart Power Grids – Talking about a Revolution // IEEE Emerging Technology portal, 2009.
17. Sinchuk I. O. Renewable and Alternative Energy Sources: study guide / I. O. Sinchuk I. O. Boyko, O. Ye. Melnyk // study guide – Kremenchug: PE Shcherbatykh O.V. Publishing House, 2015. – 270 c.
18. Power industry of Ukraine: Current State and Development Trends// National Security and Defence. – 2012. – № 6(135). -pp. 2-41

CHAPTER 2 COMPUTER SECURITY AND PROTECTION INFORMATION

The fact that information has value, people have realized for a very long time. Information is produced, stored, transported, bought, sold, and therefore falsified and stolen. That is why the information needs to be protected [1-3].

Modern society is becoming increasingly informative dependent. The success of many types of activities directly depends on the possession of certain data and the lack of these data from competitors. And the more this effect is manifested, the more urgent is the need to protect information. As for information systems, data in them is also the most valuable component. Losses from data loss or disclosure, costs for re-entering data can be much higher than the cost of hardware and software used to store them. There are many cases of companies closure due to the loss or theft of information resources.

Even non-confidential information may be accidentally destroyed by the user or deliberately attacked, may be lost during a natural disaster. Therefore, one of the most important tasks is to organize information system security. For each of us, the security of housing, car, office is a necessary thing. Otherwise, the situation looks when we speak about the information system security. Often when the disk is affected by the virus or damaged, the users begin to think about securing their systems by backing up data. However, no security system guarantees full security, and any protection involves certain costs and inconveniences for the user.

Therefore, the issue of analyzing possible threats and risks for a particular system, choosing solutions to adequately protect the system, minimizing costs and inconvenience, is relevant [4-6].

Classic threats:

- unauthorized access to resources and / or information;
- Unintentional disclosure (for example, accidental access to the password);
- different types of attacks that allow you to penetrate the network or intercept network management;
- Computer viruses, including network worms that modify and destroy information or block the work of computing systems;
- logical bombs - sets of commands written in the program and triggered under certain conditions, for example, after a certain time interval;
- "Trojan horses" - programs that perform certain actions without the knowledge of the owner of the infected system, for example, sent over the Internet

- different information from the infected computer, including the registered users' passwords;
- means of braking data exchange in networks;
- natural disasters.

Regarding natural cataclysms, for each region they have their own peculiarities, but the only effective protection against them is primarily the creation of backups of valuable information that needs to be stored in a safe place (preferably multiple copies in different geographic remote locations). Obviously, the above list may be supplemented by threats that are specific to a particular information system. In addition, it should be remembered that the methods and means of intrusion into information systems are constantly evolving. As a result, it can be argued that one hundred percent protection from all types of threats can not be provided.

Then it is necessary to estimate the probability of occurrence of each threat and possible losses (losses) after its occurrence. As a result of this analysis, all possible threats can be classified as low-risk, dangerous and critical for this information system.

The system of information system security itself does not bring profit, but its absence can cause a lot of damage [7-9].

Possible losses:

- loss of confidentiality (unauthorized access to information);
- loss of data (distortion or destruction of files);
- refusal to service users of the system;
- loss of reputation.

The latter may result in users refusing to be customers of this information system. It is most difficult to estimate financial losses from the fact that a certain number of clients after the hack will leave the company, and potential customers will not choose it. As a result, companies rarely report invasion of their information systems and data theft.

Example

The Cryptopia trading platform was attacked by hackers. At that time, more than \$ 16 million was withdrawn from the platform in a different digital currency. Hackers hacked more than 17 thousand wallets on the site. This made it possible to withdraw more than \$ 180 thousand. in the air. At the same time, the attack was carried out on the already wounded wallets. Customers did not even guess about the attack and continued to replenish their accounts. At the moment, the Exchange administration can not control the keys of direct wallets on its platform, since they are in the hands of hackers. Individual clients continue to work with the trading floor and do not even guess that it was hacked.

At the last stage, there is a choice of threats from which protection, volumes and priority of work will be realized. In defining the threats for which protection will be created, it is necessary to take into account the costs of its implementation.

Among them, for example, the material costs of the purchase of equipment and software, the cost of encryption and decryption. The costs of protecting against each threat should be adequate to the possible consequences of this threat, taking into account the likelihood of their occurrence.

The cost of protection against a particular type of threat should not exceed the losses that this threat may entail, including the loss of the recovery of the information system. Only by realizing the necessary contribution to the protection at each of the above stages can you feel confident when working with information resources.

When it comes to security of information systems, it usually means the protection of data from intruders or unintentional violation of confidentiality. However, the security of data in almost every information system depends also on the use of uninterruptible power supplies, and the availability of reliable backups. Backup is one of the most effective ways to insure against data loss due to hardware failure or natural disasters.

2.1 Security services and mechanisms of its violations

Security is a set of mechanisms, procedures and other management measures to reduce the risk of loss or disclosure. Some services provide protection against threats, others - reveal weaknesses in the security system.

The main security services are:

- authentication service;
- confidentiality service;
- service of integrity;
- compliance service.

The first step in protecting resources and the information system is to check whether a user is logged into the system for whom he or she is giving out. The verification procedure itself is called the user authentication. As a rule, the authentication procedure consists of two steps: identification and verification.

Under the identification understand the procedure of presenting the user to the system. Usually this happens by entering the name under which the user is registered on this system [10].

The second step of authentication is verification. Verification is the procedure that a system performs to ensure that the user who is logged in is

the one whose name he entered when identifying. For this purpose, the user is asked to enter a password that will be compared with the password in the account of this user account.

The use of two elements to authenticate the client makes it difficult to enter the system, since two independent barriers need to be overcome for a successful attack. If the user has successfully passed the identification (with the name that is registered in the system) and the verification (entered the password corresponding to this name), the authentication is complete. Each user who has passed the authentication process has certain rights to access the system resources.

A user account may include time restrictions, such as logging into the system only during working hours and restrictions on the place of work, for example, permission to work only with computer of the relevant department. If there is an error, special procedures are performed. It can be a display of the incorrect entry of the data and an invitation to re-enter the information.

If the number of unsuccessful login attempts exceeded a certain number, the user may be denied retry authentication. To restore access rights to the system, you may be asked to answer a secret question, the answer to which is recorded in the system when registering or re-registering the user. The parameter used to make decisions about the impossibility of repeated logon attempts can be the time allocated to the user to successfully log on. The right to re-enter the system may also be resumed after a personal appeal to the administrator [11].

Among the alternative authentication methods, biometric ones should be noted. In our time, they become widespread not only in the top-secret organizations, but also in mass-use systems. For example, modern laptops and pocket computers are often equipped with fingerprint scanners.

Biometrics is a science that measures the characteristics of the human body. Physical characteristics such as fingerprints, retinal pattern and eye iris, voice, and others can be used as a means of authentication. In the process of registering a new user, a certain physical characteristic is read and written to the database for subsequent use. This recorded characteristic is called a template. When performing authentication, the corresponding characteristic of the person is read, converted into a digital code and compared with the template. Since biometric measurements almost always have variations, comparisons require that they fall into a certain value zone, rather than a complete pattern match. Based on the comparison results, we can decide if the user whose person is being checked is really the one for whom he / she is being issued.

There are methods for recognizing a person by biometric characteristics:

- fingerprint recognition;
- Optical recognition of the retina and iris of the eye;
- Voice recognition;
- signature recognition;
- recognition by facial features;
- speech input dynamics recognition.

The latest technology is based on the fact that every person has its own way of working on the keyboard. In memory of the computer is introduced not only the name and password of the user, but also his "keyboard portrait", which is determined by the dynamics of the character input.

At the same time, biometric authentication has a number of disadvantages: the biometric template is compared not with the result of the initial processing of user characteristics, but with that came to the place of comparison. A lot of things can happen during the course of the journey. The template base can be changed by an attacker. It is necessary to take into account the difference between the application of biometrics in a controlled area and in "field" conditions when, for example, a device can be displayed on a scanning device, etc. Some biometric data of a person change (both as a result of aging and injuries, burns, cuts, illnesses, amputations, etc.) so that the template base requires constant maintenance, which creates some problems for both the user and the administrator. If your biometric data have stolen or they are compromised, then this is usually for life.

Passwords, with all their unreliability, can be changed. The finger, eye or voice can not be changed, at least quickly. Biometric characteristics are unique identifiers, but they can not be kept secret.

Example

At the end of 2018, Delta Air Lines plans to establish a network of biometric terminals at the Hartsfield-Jackson International Airport in Atlanta, USA. Biometric control systems are in partnership with US Customs and Border Guards. The system of biometric control is carried out in two stages. The first stage of the check is carried out after the passenger has passed the procedure for scanning the boarding pass and passport, and the video camera, which makes several photos, is activated. The safety system checks automatically the passenger's name and name, indicated in the passport and in the landing pass. The system then compares the biometric features of the passenger's face with the photo in the passport. If any of these items does not match, the subsequent access to the passenger is blocked. The second stage of the airborne security screening process is carried out in the AIT module (Advanced Imaging Technology - Advanced Imaging Technology). In other

words, it's a full-height scanner. This check is intended to reduce the passage time of the passenger security procedures and reduce the number of procedures for personal inspection. AIT scanners are absolutely safe for passengers. The energy emitted by millimeter waves is 1000 times lower than the permissible norm approved by international safety standards. The manufacturer assures that the consequences of talking on a mobile phone are an order of magnitude more harmful than the radiation of this scanner. However, as long as the program is in pilot mode, all passengers who have passed biometric control still undergo ordinary manual control [1-3].

In the summer of 2019, the largest British airport in Heathrow plans to install test scanners for passenger identification at all departure terminals. The project, priced at £ 50m (\$ 64.9m), will significantly reduce time at the airport for departure from the country, since no board pass or boarding passage is required for boarding an aircraft. It is expected that the checking time will be reduced by an average of one third. Person-recognition scanners will be based on the same technologies as control for holders of passports with built-in chips (electronic passports). However, only the passengers who downloaded the passport data and the photo in a special application on the smartphone will be able to use this system. If the tests are successful, face detection scanners will be installed at all terminals and this will become the largest application of biometric technologies in the world. A similar system is being tested at Sydney Airport. In addition, facial recognition systems are already used in Heathrow on domestic flights.

Authentication through geographic location

- Authentication by GPS
 - Authentication based on the Internet access point
- Authentication by GPS

The latest direction of authentication is the proof of authenticity of the remote user by its location. This protective mechanism is based on the use of a space navigation system, such as GPS (Global Positioning System).

A user with GPS equipment repeatedly sends the coordinates of given satellites in the zone of direct visibility. The authentication subsystem, knowing the orbits of satellites, can accurately measure up to a meter to determine the user's location. The high reliability of authentication is determined by the fact that satellite orbits are susceptible to fluctuations, which are difficult to predict [3].

In addition, the coordinates are constantly changing, which reduces the possibility of their interception.

The complexity of hacking the system is that the equipment transmits a digitized satellite signal without producing any calculations. All location calculations are performed on the authentication server.

The GPS equipment is simple and reliable in use and relatively inexpensive. This allows it to be used in cases where an authorized remote user should be in the right place.

Authentication based on Internet access

This mechanism is based on the use of information about the location of servers, wireless access points, through which connection to the Internet.

The relative ease of hacking is that location information can be modified using so-called proxies or anonymous access systems.

Confidentiality means that access to information may only be granted to those entities that have the right to do so. If necessary, data encryption is used to ensure confidentiality.

The data integrity service provides protection against deliberate or accidental data modifications. For example, information stored in a database is required a protection or transmitted through communication channels. The electronic nature of these data has a number of properties that complicate their protection. The electronic document is a sequence of binary bits, so determine whether this sequence is the original or its distorted copy. Changing the bits in the computer's memory or in the stream that is transmitted in the channel does not leave any physical traces. Cryptographic checksums may be used to protect electronic documents. The data integrity service can detect the fact of a change, partial deletion and addition of data.

The compliance service ensures that the participants of the information exchange will not be able to object to the fact of their participation in it. That is, for example, the sender cannot refuse the fact of data transmission, the addressee cannot refuse from the fact of their reception. This service can be implemented through the use of a digital signature.

Depending on the profile of the information system in the first place there may be different requirements [1-3]:

- ensuring confidentiality of information;
- ensuring data integrity, for example, the impossibility of making changes to payment orders;
- ensuring the system's trouble-free operation, for example, providing certain services.

Normal information flow and violations mechanisms of its security.



Normal flow

Figure 2.1 – Data security breach mechanisms

There are four such mechanisms of data security breach.

- Disconnecting. System resource is destroyed or becomes inaccessible for use (Fig. 2.2). This disrupts the availability of data.

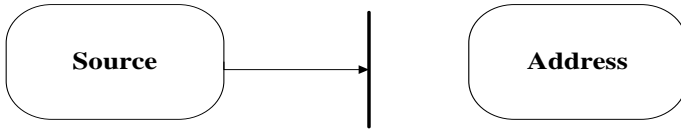

Disconnect

Figure 2.2 – Mechanisms of data security breaches

- Interception. The resource opens unauthorized access (Fig.2.3). In this case, the confidentiality of data is violated.

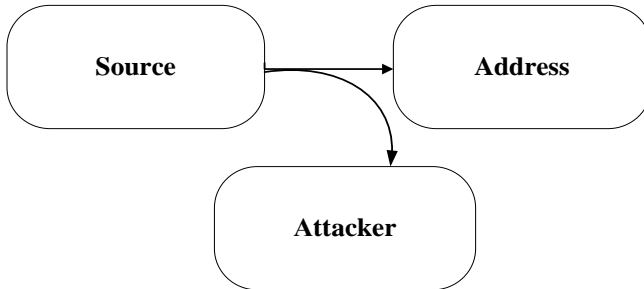

Interception

Figure 2.3 – Mechanisms of data security breach

- Modification. The resource not only opens unauthorized access, | An attacker can also change the resource (Figure 2.4). In that case is violated

data integrity. The recipient can accept modified by the attacker file as the original.

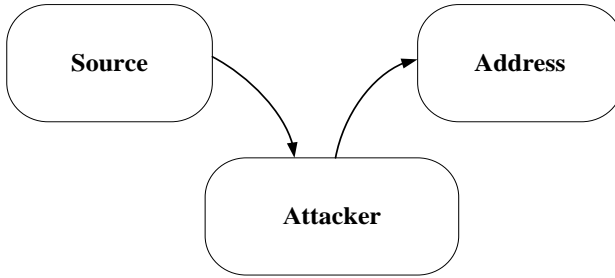

Modification

Figure 2.4 – Mechanisms of data security violations

- Falsification. An intruder inserts a malicious object into the system (Fig. 2.5). In this situation, authenticity is violated.

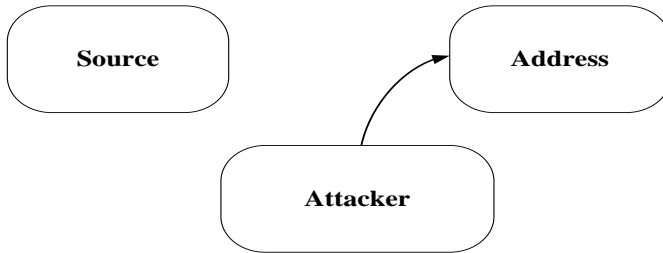

Falsification

Figure 2.5 – Mechanisms of data security breach

2.2 Development of information technologies

The current state of information technology is characterized by [2]:

1. The presence of a large number of industrial databases of a large volume, containing information about all activities of the society.
2. Creation of technologies providing interactive access of the mass user to these information resources. The technical basis of this provision that the public and private communication and data transmission systems of

general purpose and specialized data were appeared, united in national, regional and global information and computer networks.

3. Expansion of the functionality of information systems, providing simultaneous parallel processing of databases with a diverse data structure, multi-objective documents, hyper-environments, including implementing technologies for creating and maintaining hypertext databases. Creation of multifunctional software-oriented information systems for various purposes on the basis of powerful personal computers and local area networks.

4. Inclusion in the information systems intellectualization elements of the user interface, expert systems, machine translation systems and other technological tools.

There are 5 main trends in the development of information technology.

Complications of information products (services).

An information product in the form of software tools, databases and expert services becomes strategic.

Ability to interact. With the growth of the information product importance, the opportunity to make an ideal exchange of this product between the computer and the person or between information systems acquires significance of the leading technological problem. Among others, this is a compatibility problem of technical and software tools. All problems of processing the transmission of an information product must be in full compliance with compatibility and performance.

Elimination of intermediate units. The development of interoperability leads to the improvement of the information product exchange process, and therefore, in the relationship between suppliers and consumers in this area, intermediate links are eliminated. Intermediaries are not needed if you have the opportunity to place an order directly with the help of information technology.

Globalization. Firms can use information technology to do business wherever they are, by getting exhaustive information. The globalization of the information product market allows you to benefit from the cost sharing for a wider geographic region.

Convergence. The differences between products and services, information products and tools used in everyday life and for business purposes, the distinction between the transmission of audio, digital and video signals disappear.

As for business, these trends lead to the following [1-3]:

- Distributed personal computing when there are enough resources at each workplace to process information in its places of origin;
- Creation of advanced communication systems, when the enterprise

is included in the world information flow;

- Creation and development of e-commerce systems.

2.3 Systems of artificial intelligence

Promising information technologies are artificial intelligence (AI) systems that are currently used to support decision-making. They have patterns of pattern recognition (neural networks and genetic algorithms), learning and adaptation (neural networks and genetic algorithms), explanation (expert systems, fuzzy systems, genetic algorithms), flexibility-generalization (neural networks, fuzzy systems, genetic algorithms) [1-3].

In addition, modern intelligent systems are in a position to use metadata (meta-knowledge) and to discover new relationships (regularities) in data arrays. Unavailable for the systems of AI "the ability" to develop conceptual models and evaluate the values of the revealed patterns. Therefore, the person is responsible for these components, as well as the function of problem statement is the tasks formulation.

The listed components of human intelligence, not subject to modern systems of AI.

The most important operations of human thinking, is the analysis (the selection in the object of the elements and the links between them), synthesis (combining the components that make up the object), generalization (grouping elements into groups based on common signs), comparison (identification of similarity and discrepancy in objects), categorization (clusterization - in the terminology adopted in artificial intelligence). The level of developments in the theory and practice of artificial intelligence today is such that individual technologies can simulate the listed components of human thinking.

Thus, we can assume that analysis and synthesis are stimulated by dynamic structural charts and expert systems that produce downward and upward conclusions. Generalization, comparison and categorization operations are, to varying degrees, modeled by artificial neural networks, fuzzy systems and genetic algorithms.

The key characteristics of intellectual systems that determine their application in various fields of activity are [7]:

- ability to learn;
- the ability to adapt;
- flexibility;
- "transparency" of interpretation (explanation);
- the ability to open a new one.

It should be emphasized that all of these possibilities and intellectual systems are due to its internal structure and properties that simulate natural processes.

At the same time, not all intellectual technologies combine all five of these characteristics at the same time. Each of them on a set of properties is not universal and has its strengths and weaknesses. This property of intelligent systems is most important and is expressed in the fact that they can, after the appearance of input signals, self-configured, providing then the reaction (output) with the necessary accuracy.

In business, this ability of intelligent systems manifests itself in the fact that they can make decisions directly from the data, deducing a model of the domain after passing through hundreds and thousands of operations. Typically, such operational knowledge is inherent in employees with many years of experience in the organization.

Self-learning intelligent systems include neural networks, CBR technology and genetic algorithms. In the first "generations" of intellectual systems, which include, first of all, static expert systems, knowledge necessary for the task, introduced into the system "manually" by a human expert [6].

The process of defining knowledge for expert systems requires time consuming, costly and potentially unreliable. Experts consider the difficult task to express declarative (intuitive) knowledge, and sometimes they simply refuse to participate in a long procedure for extracting knowledge. It should also be borne in mind that attracting some knowledgeable professionals, such as financial brokers and insurance agents, who are involved in risk assessment, requires substantial funds to raise the value of the system being created. Consequently, the ability to learn directly on the basis of data is particularly important.

In addition, the person-professional inherent some restrictions, for example, possible gaps in knowledge and subjectivity of the truth estimates of knowledge. Frequently involved experts have different points of view regarding the accomplishment of tasks.

Unlike experts, self-learning intellectual systems do not depend on subjective factors, are more consistent, and this is their advantage.

Adaptation is the property of the system to quickly adjust its parameters under the conditions of a changing environment. As noted above, business is subject to constant change.

The reasons for the changes are, for example, the instability in the political situation and macroeconomics, the emergence of new competitors and laws governing the functioning of organizations [5].

Intelligent systems should ideally have the ability to adapt to such changes. Moreover, in some cases, the ability to adapt to rapid changes is the most significant feature of intellectual systems, since the characteristics that govern a particular market can radically change over a relatively short period of time.

For example, the known ambiguous effect of increasing interest rates on strengthening or weakening the currency. Therefore, the intelligent system used for forecasting in the financial markets should be able to adapt to complex trends and give successful recommendations, constantly learning from the market experience.

It should be noted that adaptability is at the core of the training of intellectual systems. However, the property of learning characterizes the phase of preparation of the system to work adaptation is taken to the stage of the functioning of the previously trained system.

Flexibility refers to the ability of the intellectual system to "see" the image through noise and distortion and to generalize based on incomplete, fuzzy and inaccurate data. This feature of intelligent systems allows you to overcome the strict accuracy requirement offered by a regular computer, and opens the way to the system, which can deal with the imperfect world in which we live.

Thus, individual intelligence systems, having previously learned part of the information about a certain class of objects, can "deduce" a generalized model, which can then be used to predict the behavior of other objects belonging to this class.

Under transparency of interpretation explanation refers to the ability of intelligent systems to provide extracted from knowledge in a form understandable to an expert or ODA. Intelligent systems have the potential to automate the decision-making process, but decisions made by the system must be clear to the person. To achieve the required level of justification of managerial decisions, the decision-making procedure itself should be transparent and open for discussion and analysis. And if some types of intelligence systems, for example, expert systems, provide transparency of the interpretation, then others, for example, neural networks do not explain their decision [1-3].

It is also important to understand the intellectual process adopted by the process of raising arguments in order to increase the reliability of its work. If the intelligent system ceases to make the right decisions, it can be "fixed" only if the process of argumentation of the solution is understandable to the person, because in this case it is easy to establish what caused the "behavior" of the system. In cases where investment decisions involving huge amounts

of money or customer savings are taken, the degree of decision-making arguments plays an extremely important role.

Transparency of intellectual systems is important for ensuring interaction between the system and the expert human. This is evidence that under certain circumstances, for example, in the event of unforeseen competition or aggravation of the political situation, the improvement of the results of the system can be called expert revisions of decision-making models. Such expert revisions can be viewed with known assumptions as a common "brain attack" of people and the intellectual system. Since only a person is able to understand the significance of events and operatively | to communicate with the outside world, to improve the efficiency of decisions taken jointly by the expert and the system, it is important that the system provides access to their knowledge, and in a form that is understandable to a person. The discovery of the new means the ability of intelligent systems to detect previously unknown, hidden links and relationships in large arrays of numeric and text information, to predict the emergence of new business processes.

Data mining technology is an example of extracting previously unknown and potentially useful data from the data. However, it is usually necessary to conduct additional studies to confirm that the discovered relationships are really significant.

In addition to these basic capabilities, some intelligent systems in some cases can additionally have the following properties [3-7]:

- versatility;
- nonlinearity;
- parallelism;
- stability;
- creativity

Universality refers to the ability of the system to solve a wide range of problems (to approximate any function) and to be free of any assumptions about the data source. The basis of universality lies in the completeness of the functional basis, that is, the possibility of generating a set of functions (any function).

Under nonlinearity is understood the ability to approximate arbitrarily complex nonlinear functions with any pre-set precision. At the core of the nonlinearity lies the property of the system to implement a nonlinear nonparametric regression.

Parallelism means parallel processing of information. At the heart of parallelism lies the corresponding architecture of processor elements of the system.

Sustainability refers to the ability of the system to continue to perform the task, while maintaining the proper quality of the solutions, in conditions where the part of its structure is damaged. The basis of stability is distributed memory, that is, such a property of the structure of the system, in which each "portion" of input data is contained in any element of the structure, and vice versa, each element of the structure stores information about all "portions" of input data [11].

Creativity refers to the ability of the intellectual system to generate new (which did not meet during the study) solutions to the problem. Transparency of intellectual systems is important for ensuring interaction between the system and the expert human. This is evidence that under certain circumstances, for example, in the event of unforeseen competition or aggravation of the political situation, the improvement of the results of the system can be called expert revisions of decision-making models.

List of references for chapter 2

1. Azarova, A. O. Informatyka ta komp'yuterna tekhnika (Chastyna 1): Navchal'nyy posibnyk / A. O. Azarova, A. V. Poplavs'kyy. – Vinnytsya: VNTU, 2012. – 361 s.
2. Borysenko O.M. Osnovni problemy kiberbezpeky transportnoyi haluzi /O.M. Borysenko // Aviatsiya, promyslovist', suspil'stvo: Zbirnyk tez dopovidey II Vseukrayins'koyi naukovo-praktychnoyi konferentsiyi molodykh vchenykh, kursantiv ta studentiv, 15 travnya 2019 r., m. Kremenchuk. – Kremenchuk, PP Shcherbatykh O.V., 2019.- S. 84-85
3. Borysenko O.M. Informatsiyina bezpeka v aviatsiyiniy haluzi / O.M. Borysenko // Zbirnyk tez dopovidey Mizhnarodnoyi naukovo-praktychnoyi konferentsiyi «Spil'ni diyi viys'kovykh formuvan' i pravookhoronnykh orhaniv derzhavy: problemy ta perspektyvy» (12-13 veresnya 2019r.). – Odesa.: Viys'kova akademiya, 2019. – S. 218.
4. Borysenko O.N. Problemy kyberbezopasnosty y puty ykh reshenyya / M. M. Hordyman, Sokolov D.M., O.N. Borysenko // Aviatsiya, promyslovist', suspil'stvo: Zbirnyk tez dopovidey II Vseukrayins'koyi naukovo-praktychnoyi konferentsiyi molodykh vchenykh, kursantiv ta studentiv, 15 travnya 2019 r., m. Kremenchuk. – Kremenchuk, PP Shcherbatykh O.V., 2019.- S. 168-170.
5. Brods'kyy YU. B. Komp'yutery ta komp'yuterni tekhnolohiyi: Navchal'nyy posibnyk / YU. B. Brods'kyy, K. V. Molodets'ka, O. B. Borysyuk, I. YU. Hrynychuk. – Zhytomyr: Vyd-vo «Zhytomyr's'kyy natsional'nyy ahroekolohichnyy universytet», 2016. – 186 s.
6. Buynys'ka O. P. Informatsiyini tekhnolohiyi ta tekhnichni zasoby navchannya. Navchal'nyy posibnyk - Kam`yanets'-Podil's'kyy: PP

- Buynyts'kyy, 2018. – 240 s.
7. Zavads'kyy I. O., Zabolotnyy R. I. Osnovy vizual'noho prohramuvannya. Navchal'nyy posibnyk – K.: Vydavnycha hrupa VNU, 2007. – 272 s.
 8. Kozlovs'kyy A. V., Panochyshyn YU.M., Pohrishchuk B.V. Komp'yuterna tekhnika ta informatsiyeni tekhnolohiyi. Navchal'nyy posibnyk. K.: Znannya, 2012. – 463 s.
 9. Nalyvayko N.YA. Informatyka. Navchal'nyy posibnyk - K.: Tsentr uchbovoyi literatury, 2011. – 576 s.
 10. Osnovy analiza y obespechenyya ynformatsyonnoy bezopasnosti smart hryd. Praktykum / Pod red. Kharchenko V. S. – Mynysterstvo obrazovannya y nauky Ukrainy, Natsyonal'nyy aérokosmycheskyy unyversytet ym. N. E. Zhukovskoho «KHAY», 2017. – 128 s.
 11. Pavlysh V. A., Hlinenko L. K. Osnovy informatsiynykh tekhnolohiy i system. Navchal'nyy posibnyk - L'viv: Vydavnytstvo L'vivs'koyi politekhniky, 2013. – 500 s.

CHAPTER 3 NORMS, REQUIREMENTS AND LABOUR PROTECTION USING COMPUTER TECHNIQUE

3.1 Generals of labour protection using computer technique

Today it is difficult to imagine activities without the use of computer technology. Due to the mass nature of work performed by employees with the help of a computer, the legislation of Ukraine clearly regulates the norms and requirements for the use of computer equipment at the enterprise, and also the protection of the work while working with the computer. The list of normative legal acts is quite wide. Most of the normative acts are acts of the subordinate level - rules, instructions, state sanitary rules and norms (DSANPIN), etc., which regulate individual moments regarding the actual design of computer equipment, the features of the arrangement of premises for work with it and a number of other requirements. The system of state standards regulating the conditions for the safe exploitation of computer equipment consists of [1-7]:

UNSS EN 60950-1:2015 "Information technology equipment. Security.

Part 1. General requirements »;

UNSS ISO / IEC 24767-1: 2016 «Information technologies. Internal network security. Part 1. Safety requirements »;

UNSS EN 41003: 2014 «Equipment that connects to telecommunication networks and / or cable distribution systems. Additional security requirements »;

UNSS EN 60065: 2014 "Audio, video and similar electronic equipment. Security requirements ";

UNSS EN 60728-11: 2015 "Television and audio broadcasting and interactive multimedia services. Cable Distribution Systems. Part 11. Security requirements »;

UNSS IEC 60950-21: 2010 "Equipment for information processing. Security. Part 21. Remote power supply ";

UNSS EN 60215: 2015 «Radio transmission equipment. Security Requirements »;

UNSS IEC 62040-1: 2010 "Uninterruptible Power Supplies. Part 1: General requirements and safety requirements ";

UNSS IEC 60847: 2003 "Characteristics of local area networks";

UNSS EN 60950 «Equipment for information processing. Security";

UNSS IEC 60950-21: 2010 "Part 21. Distant Power Supply" (effective until 01.01.2018);

UNSS EN 60950-22: 2014 «Part 22. Equipment installed outside the premises Development»;

UNSS IEC 60950-23: 2010 «Part 23. Equipment for the accumulation of information of a large volume» (effective until 01.01.2018);

UNSS EN 62368-1: 2015 "Equipment for audio, video, information and communication technologies. Part 1. Safety requirements »;

UNSS -H IES Guide 112: 2006 "Guidelines for the safety of multimedia equipment";

-N PMG 48: 2007 "Procedure for the exchange of documents in electronic format";

Ergonomic requirements when working with computer technology are determined by state standards, for example, the series DSTU ISO 9241 «Ergonomic requirements for work with video terminals in the office» [7-11]:

- DSTU ISO 9241-1: 2003 «Part 1. General provisions»;

- DSTU ISO 9241-2: 2004 "Part 2. Guidelines for setting requirements for tasks";

- DSTU ISO 9241-3: 2001 «Part 3. Requirements for video terminals»;

- DSTU ISO 9241-5: 2004 «Part 5. Requirements for the layout of the workplace and the working posture»;

- DSTU ISO 9241-6: 2004 «Part 6. Requirements to the working environment»;

- DSTU ISO 9241-7: 2004 «Part 7. Requirements for displays with imprints»;

- DSTU ISO 9241-8: 2006 «Part 8. Requirements for display colors»;

- DSTU ISO 9241-9: 2004 «Part 9. Requirements for non-key input devices»;

- DSTU ISO 9241-10: 2001 "Part 10: Principles of Dialogue";

- DSTU ISO 9241-11: 2006 «Part 11. Guidelines for Adequacy in Use»;

- DSTU EN ISO 9241-12 «Part 12. Presentation of information.

Development of national ND "(under development);

- DSTU EN ISO 9241-13 «Part 13. Instructions for use.

Development of national ND "(under development);

- DSTU EN ISO 9241-14 «Part 14. Dialogue menu. Development of national ND "(under development);

DSTU ISO 13406-2: 2006 "Ergonomic requirements for working with flat screen video terminals. Part 2. Ergonomic Requirements for Flat Screen Displays. "

In all developed countries there are hundreds of documents that regulate the requirements not only for computers, but also for the organization of workplaces with their use. Uncontrolled use of computer equipment can lead to negative impact on the health of computer users.

The World Health Organization, in 1989, in the offset publication No. 99 "Video Display Terminals and Users Health" did the conclusion that work with the use of personal computers is accompanied by visual and nervous-emotional stress, negative changes in the bone human brain system.

Electronic computing machine (computer), the equipment with optional additional devices (printers, scanners, modems, uninterruptible power supplies and other special peripherals).

Video Display Terminal (monitor) - a part of an electronic computer that contains a device for visual display of information;

Peripherals are a set of optional additional devices used in the process of the operator of a computer (keyboard, mouse manipulator, disk system, sound system, modem, microphone, printer, scanner, etc.).

At the enterprise, where computer equipment is operated, a security service is created in accordance with the Model Regulations on the labor protection service, approved by the order of the State Supervision Protection Labor of Ukraine dated November 15, 2004 No. 255.

The operation of computers at enterprises is carried out in accordance with the "Requirements for the safety and health of workers in working with screen devices", approved by the Order of the Ministry of Social Policy of Ukraine on February 14, 2018, No. 207 and "State Sanitary Rules and norms of work with visual display terminals of electronic-computing machines "(approved by the Decree of the Chief State Sanitary Doctor of Ukraine No. 7 of December 10, 1998, 3.3.2.007-98).

Security requirements for the installation of the power supply network of the computer are regulated by: Rules for the installation of electrical installations, approved by the order of the Ministry of Fuel and Energy of Ukraine dated July 21, 2017 No. 476; Rules of technical exploitation of electrical installations of consumers, approved by the order of the Ministry of Fuel and Energy of Ukraine dated 25.07.2006 № 258; and Rules of safe operation of electrical installations of consumers, approved by the order of State supervision labor protection of 09.01.1998 No. 4. General requirements of fire safety during the operation of computer equipment are determined by the Fire Safety Regulations in Ukraine, approved by the order of the Ministry of Internal Affairs dated December 30, 2014, No. 1417.

The rooms in which the installation and further work with the computer are planned should be in accordance with the design documentation of the house agreed with the authorized state authorities. In addition, the

employer must take into account the existing sanitary norms of lighting, requirements for microclimate parameters (temperature, relative humidity), the degree and vibration forces, noise and fire resistance of the rooms, as well as characteristics of electromagnetic, ultraviolet and infrared fields [9].

State Sanitary Rules and dos and don'ts 3.3.2.007-98 apply to the conditions and organization of work when working with visual display terminals (VDT) of all types of domestic and foreign manufacture on the basis of electron-beam tubes used in electronic computers for collective use and personal computer (PC). For example, the employer is forbidden to install computers in rooms located in cellars.

To avoid possible accidents and short circuit, near the rooms where the work with the computer (over or under) will be performed, it is not allowed to do the work which is in excessively damp technological processes. The appropriate room should be equipped with central or individual heating, air conditioning or ventilation systems. But when installing these systems, it is necessary to make sure that the heating batteries, water pipes, ventilation cables, etc., are securely hidden under protective shields that will prevent the workers from charged with electricity.

Permissible sound levels are equivalent to sound levels and sound pressure levels in octave frequency bands [1-3].

Kind of labor activity, workplaces	sound pressure levels dB									
	in octave bands with average geometric frequencies, Hz									
	31,5	63	125	250	500	1000	2000	4000	8000	Sound levels, equivalent to sound levels, dBA / dBeq.
Computer programmers	86	71	61	54	49	45	42	40	38	50
Operators in the information processing halls and operators of typesetting services	96	83	74	68	63	60	57	55	54	65
In the rooms for the location of noisy units of the computer	103	91	83	77	73	70	68	66	64	75

Standards of microclimate for rooms with visual display terminal (VDT) of computers *

Season	Category of work	Air temperature, deg.cent. not more	Relative humidity, %	Speed of air movement, m / s
cold	easy-1a	22 - 24	40 - 60	0,1
	easy-1b	21 - 23	40 - 60	0,1
easy	легка-1a	23 - 25	40 - 60	0,1
easy	легка-1b	22 - 24	40 - 60	0,2

Levels of air ionization of rooms when working on a VDT computer and PC *

Levels	Number of ions in 1 cube. sm air	
	n+	n-
Minimum needed	400	600
Optimal	1500 - 3000	3000 - 5000
Maximum permissible	50000	50000

3.2 Lights of general lighting

In the absence of fixtures of the series LPO36 with HF PND and without HF modification of the "skew" the use of common lighting fixtures series: LPO13 - 2 x 40 / B - 01; LPO13 - 4 x 40 / B - 01; LPO13 - 2 x 40 - 06; LPO13 - 2 x 65 - 06; LSO05 - 2 x 40 - 001; LSO05 - 2 x 40 - 003; LSO04 - 2 x 36 - 008; LPO34 - 4 x 36 - 002; LPO34 - 4 x 58 - 002; LPO 31 - 2 x 31 - 002, as well as their domestic and foreign counterparts [12].

Sanitary standards of vibration category 3 of the technological type "B"*

Average geometric frequencies of bands, Hz	Acceptable axis values X, Y, Z							
	vibration acceleration				vibration speed			
	m / cm in c. 2		dB		m / s * 10 in c. -2		dB	
	1/3 oct	1/1 oct	1/3oct	1/1 oct	1/3 oct	1/1oct	1/3 oct	1/1 oct
1,6	0,0125		32		0,13		88	
2,0	0,0112	0,02	31	36	0,089	0,18	85	91
2,5	0,01		30		0,063		82	
3,15	0,009		29		0,0445		79	
4,0	0,008	0,014	28	33	0,032	0,063	76	82
5,0	0,008		28		0,025		74	
6,3	0,008		28		0,02		72	
8,0	0,008	0,014	28	33	0,016	0,032	70	76
10,0	0,01		30		0,016		70	

12,5	0,0125		32		0,016		70	
16,0	0,016	0,028	34	39	0,016	0,028	70	75
20,0	0,0196		36		0,016		70	
25,0	0,025		38		0,016		70	
31,5	0,0315	0,056	40	45	0,016	0,028	70	75
40,0	0,04		42		0,016		70	
50,0	0,05		44		0,016		70	
63,0	0,063	0,112	46	51	0,016	0,028	70	75
80,0	0,08		48		0,016		70	
Adjusted and equivalent adjusted values and their levels	0,	14		3	0,02			5

The valid parameters of electromagnetic non-ionizing radiation and electrostatic field

Types of fields	Permissible field parameters		Permissible superficial energy flow density (intensity of energy flow), W / sq. m
	for electrical component (E), W / m	by the magnetic component (H), A / m	
Voltage of the electromagnetic field			
60 kHz to 3 mHz	50	5	
3 kHz to 30 mHz	20	-	
30 kHz to 50 mHz	10	0,3	
30 kHz to 300 mHz	5	-	
300 kHz to 300 gHz	-	-	10 W / sq. m
Electromagnetic field of the optical range in the ultraviolet part of the spectrum:			
UV-C (220-280 nm)			0,001
UV-B (280 - 320 nm)	-	-	0,01
UV-A (320-400 nm)			10,0
in the visible part of the spectrum:			
400 - 760 nm			10,0
in the infrared part of the spectrum:			
0,76 - 10,0 mkm			35,0 - 70,0
Voltage of electric field of VDT			20kW / m

In each room or office, where the workplaces will be for employees working with the computer, natural and artificial lighting elements should be available. In this case, the windows should be installed easily adjustable blinds or curtains that will allow workers to adjust the level of lighting in the room. It is advisable to place computers in the room so that light falls on monitor screens from the south or north-east. In order to achieve the

maximum level of safety and work safety when working with a computer, the production facilities should be equipped with first-aid kits, automatic fire alarm systems and fire extinguishers. In a room in which 5 or more computers operate together, a service switch is installed at a visible location. If it is necessary, this switch will completely cut off the room's power supply. Computer equipment should only be connected to the mains with the help of proper plug-in connections and factory-made electricians. In plugs and electrical outlets, in addition to the contacts of the phase and zero working conductors, there must be special contacts for connecting the zero protective conductor. Their construction should be such that the connection of the zero protective conductor occurred earlier than the connection of the phase and zero working conductors. Disconnection must be reversed. It is not allowed to connect computer technology to conventional two-wire mains, in particular using transceivers [13].

An employer who uses hired labor workers has to ensure that their workplaces are in line with comfortable and secure conditions. The size of one work place should be at least 6 square meters. If necessary, the adjacent workplaces of employees working with the computer should be divided into partitions up to 2 meters high. When determining the size of the room and the work space for one person, it is necessary to take into account additionally cabinets, safes, curbstones or other objects of furniture or equipment that are in the room.

Personal computers also belong to the computer. The work of employees working with computers is associated with increased visual and nervous-emotional stress, so this work is related to work with a special nature of work. In addition, work on visual display terminals (VDT) is accompanied by harmful factors associated with forced working posture with local tension of the upper limbs against the background of limited overall muscle activity and the influence of a complex of physical factors of noise, electrostatic field, non-ionizing and ionizing electromagnetic Radiation (the values of which do not exceed the maximum permissible levels).

Video terminal, video monitors and displays are synonyms, because these are devices for displaying information. The analysis of normative documents gives grounds to assert that the term "display" is more often used than the "video monitors" on the display of information display device. And the terminal is a monitor (display) with a keyboard connected to the computer system, which is designed to carry out payment, search and other operations [14].

The display is the main source of danger. It produces radiation of several types: X-ray, ultraviolet, infrared, electromagnetic. For each of these radiation, maximum permissible standards have been developed, but they are

rather conditional and different in each country. The norms anticipate that the entire human organism is irradiated, but in reality only the upper part of the body is exposed. The mentioned norms are established on the basis of each type of radiation separately, although all the fields are actually valid at the same time, and their complex effects have not yet been investigated.

In addition, the video display terminal violates the equilibrium between positively charged and negatively charged ions in the air. The electrostatic field of the display attracts negative ions, thus violating the overall balance of the atmosphere. It also damages health. Already after an hour of work near the monitor there is almost complete disappearance of negative ions. This is why it is necessary to have fresh air around the workplace at the computer [15].

The replacement of electron-beam monitors by liquid crystal partially reduces the visual load of workers and the impact of non-ionizing and ionizing electromagnetic radiation, but does not significantly affect other factors. Individual categories of workers whose work is associated with increased nervous-emotional and intellectual load, or this work is performed in special natural geographic and geological conditions and in conditions of increased risk for health, provide annual additional leave. Employees who work at least one-half the length of the working day on electronic computers and whose length of annual leave is not specified by other regulations, are entitled to annual additional leave for working with a computer till 4 calendar days [16].

On the table of the employee, you can make additional equipment (printers, columns, scanners), and also a copy for the document, however, you can't see the screen and don't reflect on the screen. In case of supra-noise, or vibration of technical equipment, the employer is obliged to give them anti-vibration rugs. The chair is must be turning, we can easily control the visibility and the back and the ridge of the individual. Every day it is necessary to do wet cleaning, and clean the work place and computer monitor from the dust.

It is prohibited at the company: to carry out repairs and maintenance of the computer at the workplace of the employee; self-repair or attempt to perform technical adjustment of the computer without the involvement of competent specialists; to store unnecessary documents in the workplace, parts and items that are not needed for work; use monitors with fuzzy images and monitors that have broken screens; work with a matrix printer without anti-vibration coating and with a removed lid. It is not allowed for persons to work who have not passed the approved course of labor protection for work with a computer.

3.3 *Dangers in working with computer*

Dangers in working with computer equipment are [17]:

- electric shock; energy danger (it appears due to short circuit: burns, electric arc, discharge of molten metal);
- danger of fire;
- Thermal hazards (the effect of high temperatures due to the heating of structural elements);
- mechanical hazard (injuries due to falling, the effect of moving parts, the cut for the sharp parts of the structural elements);
- danger of radiation (the effect of sound (acoustic), high frequency, infrared, ultraviolet and ionizing radiation, as well as visible light of coherent high intensity (laser radiation));
- chemical hazard (contact with certain chemicals used to service the equipment or from inhalation of their vapors).

Working with visual display terminals (VDT) of electronic computers (computers) of collective use and personal computers (PCs) are subject to compulsory medical examinations: the previous one - when making a job and periodic - during work.

Such medical examinations are carried out in accordance with the requirements of the Procedure for conducting medical examinations of workers of certain categories, approved by the ministry of health order dated May 21, 2007 No. 246 (Order number 246).

The main criteria for assessing the suitability for work with VDT COMPUTER and PC should be indicators of the state of the organs of vision: visual acuity, refractive index, accommodation, the state of the binocular apparatus of the eye, etc. It also takes into account the state of the organism as a whole.

To contraindications for work with computers include all chronic forms of mental illness, endocrine diseases, severe degree of the bronchial system, hypertonic disease of the 3d stage and other diseases.

Workers who work with computers are subject to mandatory prior and periodic medical examinations [18].

A pre-medical examination is conducted during recruitment with the aim of:

- determination of the health's state of the worker and the registration of the outgoing objective health indicators and the ability to perform without degrading the health of professional duties in the context of specific harmful and dangerous factors of the production environment and labor process;
- identification of occupational diseases (poisonings) that occurred

earlier in the work at previous enterprises, and prevention of productive and occupational diseases (poisonings).

Periodic medical examinations are conducted to [19]:

- timely detection of early signs of acute and chronic occupational diseases (poisonings), general diseases at the workers;
- ensuring the dynamic monitoring of the workers health in conditions of harmful and dangerous production factors and labor process;
- solving the issue of the possibility of an employee to continue working under the conditions of specific harmful and dangerous production factors and labor process;
- development of individual and group medical and preventive and rehabilitation measures for employees assigned according to the results of the medical examination to the risk group.

The question of suitability for work in each individual case is solved individually, taking into account the peculiarities of the functional state of the organism (nature, degree of manifestation of the pathological process, the presence of chronic diseases), working conditions and the results of additional methods of examination.

At the same time, each doctor who participates in the examination of the patient gives a conclusion on the state's health of the worker, confirms his personal signature and personal seal, participates in the final discussion of the suitability of the person under examination to work in the chosen profession and, if necessary, determines the therapeutic actions.

According to the results of periodic medical examinations (within a month after their termination), the commission on medical examinations of health facilities shall draw up the Final Act on the results of periodic medical examination of workers [13-19].

When hiring, each person must undergo a medical examination. In addition, during further work in the company, such person is subject to a regular medical examination at least once every 2 years. It is obligatory to pass such doctors as a therapist, a neurologist and an ophthalmologist.

The company should have clear breaks for the rest of workers (except for dinner), usually for a duration of 10-15 minutes per hour or two, depending on the complexity of the work.

During a regulated break in order to reduce the nervous-emotional tension, fatigue of the visual analyzer, elimination of the effects of hypodynamia and hypokinesia, prevent the development of fatigue, it is expedient to perform complex exercises. The noise level in the room during the operation of computers should not exceed 50 dBI.

The design of a video monitor should include measures that ensure good image clarity, independent of external lighting.

Depending on the purpose and scope of the video, the terminals can be divided into the following groups [20]:

- Group A - color monitors for demonstration purposes only;
- Group B - color monitors for personal work.

It is strictly forbidden to use electric heating elements with open element open fire in the workplace.

Use of heated heating devices with closed heating elements is only allowed in specially designated places.

In any case, the employer must provide such a timetable for the company so that the time of uninterrupted work with the computer was not more than 4 hours. Additionally, in order to maintain the proper level of health and professional suitability of workers, it is recommended to allocate in the enterprise a separate living space for respite of workers and removal of their nervous-emotional stress that occurs when working with a computer.

Requirements for the safety and health protection of workers in such work, approved by the order of the Ministry of Social Policy from February 14, 2018, No. 207. The order was registered in the Ministry of Justice on April 25 and will come into force on the day of official publication. These requirements apply to all economic entities, regardless of ownership, organizational form and type of activity. At the same time, they do not apply to computer classes (cabinets, auditoriums, etc.) of educational institutions and workplaces of staff engaged in the maintenance, repair and adjustment of on-screen devices. It is the employer's responsibility to inform workers on the terms of work and the availability of hazardous and harmful production factors (physical, chemical, biological, psychophysiological) at their work places that occur when working with screen devices and are not yet eliminated, and also about the possible consequences their impact on health. The employer, at his own expense, ensures the medical examinations of workers and.

Workplaces must be designed and dimensioned in such a way that workers have the space to change their working position and movements. All elements of the workplace and their location must comply with ergonomic, anthropological, psycho-physiological requirements, as well as the nature of the work performed. Lighting should create the appropriate contrast between the screen and the environment (taking into account the type of work).

The microclimate of industrial premises should be maintained at a constant level and comply with the requirements of the sanitary norms of the DSN 3.3.6.042-99. The desktop or the working surface should be of sufficient size and low reflectivity, allow flexibility when placing the screen, keyboard, documents and related equipment. The working armchair must be stable and allow the worker to move easily and occupy a comfortable position. The seat

should be adjusted in height, the seatback - both in height and on a slope. There should be a footrest for those who need it for convenience. Every day before work, it is necessary to clean screen devices from dust and other contaminants. It is not allowed to work with on-screen devices, which show unusual signals during operation, an unstable image on the screen, and other malfunctions. Also, the minimum security requirements for the on-screen devices are set [21].

Today, work with computer technology is closely linked with the use of the World Wide Web. Excessive use of the Internet has a detrimental effect on the psyche and social position of a person in society. But, in addition, it can lead to such serious problems of physical health as:

- headaches;
- fatness;
- bad general feeling due to lack of physical activity.

Any dependence has similar leakage symptoms. Therefore, the Internet addiction (Internet addiction) also falls under this symptomatology. There are three main symptoms [22]:

- Increasing the dose (increasing the time spent on the Internet)
- Behavioral changes (life on the Internet begins to replace a real life)
- Abnormal syndrome (discomfort outside the Internet).

The presence of such symptoms should already make you think about a possible problem. If there are such changes in the relationship with the Internet, then this is the time to sound the alarm. The Internet is a huge informational field that brings a lot of benefits. In the course of work, employees in the search for information are simultaneously beginning to go to chats and forums that do not belong to work, begin to chat in chat, play online games, and thus distract. They do not have enough time to prepare for the tasks they have, there are problems with controlling the time spent on the Internet, they do not sleep at night.

In the Internet-dependent person, the following health problems are often observed [23-25]:

- Deterioration of vision;
- Fatigue and irritability;
- Spine problems (osteochondrosis, scoliosis);
- Reduced immunity;
- Pain in the wrist;
- Headaches.

It is known that people who are addicted to the Internet get more than 9 hours per week of spending time at the computer. Therefore, if an employee deliberately spends more than 2 hours a day on the Internet, if he

(she) is annoyed by the lack of the Internet, if her (his) style of behavior and habits has changed, then the computer dependence has already begun, and it will be harder to deal with it over time. Therefore, if it is not prevented in time, the computer dependence will completely absorb and destroy the person.

Computer technology is developing very rapidly today, with extremely speed, and also various technical solutions and standards are rapidly becoming obsolete and dying. According to the views of various economic and sociological organizations, computer technology and telecommunications will remain one of the most advanced industries in the world industry for at least 10-15 years. So the reduction in the number of people working on computers do not have to wait. On the contrary, gross computerization has long embraced the business sector, today it is increasingly capturing the mass consumer. Therefore, the organization of safe and comfortable working conditions with computer technology remains relevant at the present time.

List of references for chapter 3

1. Okhorona pratsi [Z. M. Yaremko, S. V. Tymoshuk, S. V. Pysarevs'ka ta in.]; za red. Z. M. Yaremka. – L'viv: LNU imeni Ivana Franka, 2018. – 430 s.
2. Protoyereys'kyi O. S, Zaporozhets' O. I. Okhorona pratsi v haluzi: Navch. posib. – K.: Knyzhkove vyd-vo NAU, 2005. – 268 s.
3. Hohitashvili H. H., Karchevs'ki YE.-T., Lapin V.M. Upravlinnya okhoronoyu pratsi ta ryzykom za mizhnarodnymy standartamy: Navch. posib. – K.: Znannya, 2007. – 367 s.
4. Osnovy okhorony pratsi / [V. V. Berezuts'kyi, T. S. Bondarenko, H. H. Valenko ta in.]; za red. V. V. Berezuts'koho. – KH.: Fakt, 2005. – 480 s.
5. Krushel'nyts'ka YA.V. Fiziolohiya i psykholohiya pratsi. – K.: KNEU, 2000. – 232s.
6. Okhorona pratsi (praktykum): Navch. posib. / Za zah. red. k.t.n., dots. I. P. Pistuna. – L'viv: Triada plyus, 2011 – 436 s.
7. Okhorona pratsi ta promyslova bezpeka: Navch. posib. / K. N. Tkachuk, V. V. Zatsarnyy, R. V. Sabarno, S. F. Kashtanov, L. O. Mityuk, L. D. Tret'yakova, K. K. Tkachuk, A. V. Chadyuk. Za red. K. N. Tkachuka i V. V. Zatsarnoho. – K.,2009 – 454 Zakon Ukrayiny “Pro okhoronu pratsi”.
8. Kodeks zakoniv pro pratsyu Ukrayiny.
9. DSanPiN 3.3.6.096-2002 Derzhavni sanitarni normy i pravyla pry roboti z dzherelamy elektromahnitnykh poliv.
10. DSN 3.3.6.042-99 Sanitarni normy mikroklimatu vyrobnychykh

- prymishchen'.
11. DSN 3.3.6.037-99 Sanitarni normy vyrobnychoho shumy, ul'trazvuku ta infrazvuku.
 12. DSN 3.3.6.039-99 Derzhavni sanitarni normy vyrobnychoyi zahal'noyi ta lokal'noyi vibratsiyi
 13. NPAOP 0.00-1.28-10 Pravyla okhorony pratsi pid chas ekspluatatsiyi elektronno-obchyslyval'nykh mashyn. Nakaz Derzhhirpromnahlyadu vid 26.03.2010r. № 65
 14. NPAOP 0.00-2.23-04 «Perelik zakhodiv ta zasobiv z okhorony pratsi, vytraty na zdiysnennya ta prydbannya yakykh vklyuchayut'sya do valovykh vytrat». Postanova Kabinetu Ministriv Ukrainy vid 27 chervnya 2003 r. № 994.
 15. NPAOP 0.00-8.24-05 «Perelik robit z pidvyshchenoyu nebezpekoyu». Nakaz Derzhnahlyadokhoronpratsi vid 26.01.2005 r. № 15.
 16. Perelik robit, de ye potreba u profesiynomu dobori. Nakaz MOZ Ukrainy ta Derzhnahlyadokhoronpratsi Ukrainy vid 23.09.1994 r. № 263/121.
 17. DSTU 2293-99 «Okhorona pratsi. Terminy ta vyznachennya osnovnykh ponyat'».
 18. Hihiyenichni normatyvy HN 3.3.5-8-6.6.1-2002 «Hihiyenichna klasyfikatsiya pratsi za pokaznykamy shkidlyvosti ta nebezpechnosti faktoriv vyrobnychoho seredovyshcha, vazhkosti ta napruzhenosti trudovoho protsesu». Nakaz Ministerstva okhorony zdorov'ya Ukrainy vid 27.12.2001 № 528.
 19. Mizhderzhavnyy standart HOST 12.0.003-74 (1999) SSBT «Opasnye y vrednye proyzvodstvennye faktory. Klassyfykatsyya».
 20. Mizhderzhavnyy standart HOST 12.0.230-2007 SSBT. Systemy upravlinnya okhoronoyu pratsi. Zahal'ni vymohy.
 21. DNB 2.09.04-87 Administratyvni ta pobutovi budivli.
 22. Rekomendatsiyi shchodo orhanizatsiyi roboty kabinetu promyslovoyi bezpeky ta okhorony pratsi. Zatverdzeni Holovoyu Derzhhirpromnahlyadu 16.01.2008 r.
 23. Rekomendatsiyi shchodo pobudovy, vprovadzhennya ta udoskonalennya systemy upravlinnya okhoronoyu pratsi. Zatverdzeni Holovoyu Derzhhirpromnahlyadu 7.02.2008 r.
 24. Perelik profesiy, vyrobnytstv ta orhanizatsiy, pratsivnyky yakykh pidlyahayut' obov'yazkovym profilaktychnym medychnym ohlyadam. Postanova Kabinetu Ministriv Ukrainy vid 23 travnya 2001 r. № 559.
 25. Dyrektyva Rady Yevropeys'kykh Spivtovarystv 89/391/EES «Pro vprovadzhennya zakhodiv, shcho spryyayut' polipshennyu bezpeky y hihiyeny pratsi pratsivnykiv».

CHAPTER 4

METHODS OF CHOOSING SCHEME SOLUTIONS FOR INTRODUCING NON-CONVENTIONAL AND RENEWABLE ENERGY SOURCES AT IRON ORE MINING ENTERPRISES

4.1 Methods of assessing the potential of non-conventional and renewable electric energy sources while introducing them at iron ore mining enterprises

In 2001, the Institute of Electrodynamics of Ukraine's National Academy of Sciences created "Atlas of energy potential of Ukraine's renewable and non-conventional energy sources" composed of 13 maps depicting energy potential of various types of alternative energy including wind, solar, geothermal and small river energy, animal and plant agricultural biomass, forest waste, extra pressure of blast-furnace gases, natural gas, mine methane, peat, thermal energy of sewage waters, heat of soil and ground waters. The atlas maps provide the data on distributing the energy potential among administrative regions and maps of wind energy resources include the data within four wind zones [1-10].

The Ukrainian maps show energy generation by certain wind turbine types which are preferred on the national wind energy market (2.5 MW Fuhrlander FL2500 and 3 MW Vestas V112). The depicted annual course of mentioned indices is required to develop season modes of wind power plants [28].

The data on repeated wind speeds in various gradations and the total duration of operating wind speeds during a year is also important for the wind energy industry, as these indices influence the utilized capacity level and operation modes to be taken into account while choosing equipment for wind turbines. Most modern wind turbines operate under the speed modes of 3-25m/sec. When the wind speed is lower than the minimum level, the aerodynamic wind power does not create the necessary rotatory moment of a wind turbine. At the same time, if the maximum wind speed exceeds, the rotatory moment can cause mechanical damages to a wind turbine.

Wind power plants occupy huge areas as generation of 1MW/year of wind energy requires 83 m² and the average value of the established capacity makes 10 MW/km² per unit area. That is why, the data on the status and the category of land lots used for wind energy development are of great practical importance.

Basic indices characterizing solar energy resources are average values of total solar radiation and insolation (direct solar radiation) coming to various surface types and their yearly character. These indices play an

important role in choosing the equipment type as different types of solar energy plants absorb different types of solar radiation as well as the installation angle depending on functional tasks and the available surface for installing solar systems. Most often, solar collectors and photo-transducers are installed at an angle to the surface to increase the density of solar beam incidence (the maximum energy is generated when the angle of solar beam incidence approaches 90°). Yet, in some projects, there arises a necessity of installing solar energy plants on the horizontal or vertical surfaces like building facades. It explains the need of compiling maps of solar radiation on various surface types. Indices of solar radiation reflect actual energy potential. Additionally, it is advisable to provide average monthly heights of the Sun, duration of solar glow, cloudiness indices that should be taken into account in determining parameters of solar energy plants, choosing equipment types, etc [10-20].

The technically achievable potential of solar energy resources reflects energy generation by a certain solar system type per unit area for a time period and is determined by their technical characteristics including the efficiency coefficient, the installation angle and horizon orientation. This factor is the basis for estimating the economic expediency of solar energy application and payback periods of constructing power or thermal plants.

In future, the data on energy objects of nuclear power plants integrated into the Geoinformation System (GIS) database can create the information basis for appendices regulating operation of electrical smart grids [29].

Considering the sizes of modern wind turbines, which are in a wide range (the height of a wind turbine support varies from 10m to 150m), wind characteristics are calculated for different heights (10m, 50m and 100m) above the surface.

To bring the wind speed in accord with the height within the surface air layer, two analytical calculation models are often applied in world practices – Laikhtman’s logarithmic law and Hellman’s exponent law, according to which and considering the stiffness ratio of the surface, the wind speed at the given height is determined by [30]:

$$V_h = V_a \left(\frac{h}{h_a} \right)^\alpha \tag{4.1}$$

and

$$V_h = V_a \frac{\ln h_a - \ln \alpha}{\ln h - \ln \alpha}, \tag{4.2}$$

where V_h is the wind speed at height h ; V_a is the wind speed at the anemometer height; h_a is the anemometer height; α is the stage coefficient

depending on the surface stiffness ($\alpha=0.05-0.50$), for the open space the parameter $\alpha=1/7=0.143$.

The calculated surface stiffness coefficient allows adapting values of average wind speeds to open space conditions. Surface stiffness coefficients for ground-based control points (meteorological sites) are determined by means of space pictures [20-30].

In the research, the specific capacity factor of the wind flow per unit area of its cross-section (the theoretical wind energy potential) is taken as an integral energy characteristic of the wind and is calculated by

$$P = 0,5\rho_{av}(V_{av}^3) \quad (4.3)$$

where P is the specific capacity of the wind flow (W/m^2); ρ_{av} is the average density of the wet air (kg/m^3); V_{av} is the wind speed (m/sec).

As is known, the wind density is conditioned by its physical state and composition including temperature, pressure and humidity. To calculate the wet air density the following equation is applied [31]:

$$\rho_{wet\ air} = 1 + \frac{P - (R_{dry\ air} \cdot T)}{R_{aq.\ vap.} \cdot T}, \quad (4.4)$$

where $\rho_{wet\ air}$ is the wet air density (kg/m^3), P is the air pressure (Pa), $R_{dry\ air}$ is the gas constant for the dry air ($287.058 \text{ J/kg} \cdot \text{K}$), T is temperature (K), $R_{aq.\ vap.}$ is the gas constant for aqueous vapour ($461.495 \text{ J/kg} \cdot \text{K}$) [35].

These indices are calculated on the basis of ground-based and satellite actinometric observations or climate modelling data. Thus, annual energy production for photoelectric systems is determined by:

$$E = Q_P S_{phP} C_{EEC} C_{ES} \quad (4.5)$$

where E is the yearly energy production by photoelectric systems (kW/hour); Q_P is the total solar radiation coming to photoelectric panels of 1m^2 , S_{phP} is the area of photoelectric panels of solar collectors; C_{EEC} is the equipment efficiency coefficient; C_{ES} is the coefficient that reflects the part of the effective surface.

As solar panels are most often installed at an angle, the solar radiation value should be recalculated according to the surface inclination of panels.

The total solar radiation access is composed of sums of direct and dispersed radiation [38]:

$$Q_P = \sum S_{DR} + \sum D_{DR}, \quad (4.6)$$

where $\sum S_{DR}$ is the monthly sum of direct radiation to the inclined surface of 1 m^2 , $\sum D_{DR}$ is the monthly sum of dispersed radiation to the inclined surface of 1 m^2 .

The flow of the monthly dispersed radiation to the inclined surface is determined by [39]:

$$\sum D_{DR} = \sum D_r \cos^2 \alpha / 2, \quad (4.7)$$

where $\sum D_r$ is the monthly sum of dispersed radiation to the horizontal surface, α is the inclination angle of the distanation surface.

The direct solar radiation access to the inclined surface is equal to [39]:

$$S'_{DR} = S_m \cos i, \quad (4.8)$$

where S_m is direct radiation near the Earth surface which comes to the normal surface for solar beams (insolation); i is the beam incidence angle to the inclined surface, while

$$\cos i = \cos \alpha \sinh_0 + \sin \alpha \cosh_0 \cos \psi \quad (4.9)$$

where α is the inclination angle of the inclined surface, h_0 is the Sun altitude,

$$\psi = \psi_0 - \psi_n, \quad (4.10)$$

where ψ_0, ψ_n are the Sun azimuths and projections of the normal built to the inclined surface on the horizontal plane; vector azimuths are deducted from the meridian space (azimuths are usually deducted by positives clockwise).

The solar altitude can be expressed by solar diclination, area latitude and the Sun hour angle:

$$\sinh_0 = \sin \varphi \sin \delta + \cos \varphi \cos \delta \cos \Omega, \quad (4.11)$$

where φ is area latitude, δ is solar declination, Ω is the Sun hour angle.

The given equations reveal that in order to calculate the technical potential, in addition to solar radiation data, one should also calculate the Sun azimuth and altitude for each point of an area.

4.2 Assessment of the wind potential at iron ore open pit dumps

The possibility of locating a wind power plant at mining enterprises' open pit dumps has been considered before.

Aerodynamic characteristics of open pits are presented in the following map [24].

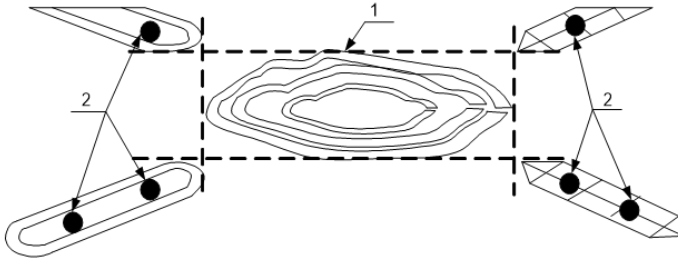

Figure 4.1 – The scheme of efficient location of wind power plants at open pit dumps

For example, Fig. 4.1 presents the scheme of efficient location of horizontal wind turbines at open pit dumps, which allows increasing the coefficient of using a wind flow under any wind direction on the surface.

There is a criterion of determining WPP profitability and payback. This criterion indicates the average wind speed within 5.1...5.9m/sec.

The average periodical wind speed should be recalculated for the given WPP height (H) by the formula [24]:

The average yearly value $m=0.2$.

$$v_H = v_h \left(\frac{H}{h} \right)^{\bar{m}}, \quad (4.12)$$

where $\bar{m} = 0,6(\bar{v}_h)^{0,77}$, and \bar{v}_h is the average periodical wind speed on the weathercock height (h).

The calculated capacity characteristics of WPP reveal that within the wind speed range of $v_H \geq v_i \geq v_{max}$ its capacity is equal to zero.

The monthly WPP production (N_{WPPmon}) and a month ($N_{WPPyear}$) is calculated by the formula:

$$W_{WPP}^{mon} = \sum_{i=1}^k N_{WPP}(v_i) \cdot t_i(v_i) \cdot T_{mon}, \quad (4.13)$$

where T_{mon} is the number of hours in a calculated month. The value $t_i(v_i)$ is taken providing Weibull distribution and depending on the parameter (γ). N_{WPP} is the WPP capacity, v_i is the instantaneous wind speed, $t_i(v_i)$ is the duration of the corresponding instantaneous wind speed.

$$W_{WPP}^{year} = \sum_{i=1}^k W_{WPP}^{mon} \quad (4.14)$$

or

$$W_{WPP}^{year} = \sum_{i=1}^k N_{WPP}(v_i) \cdot t_i \cdot (v_i) \cdot T_{year}, \quad (4.15)$$

where $T_{year} = 8760$ hours [8].

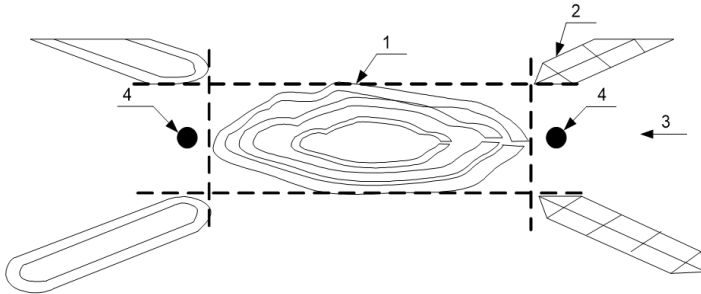

Figure 4.2 – The scheme of efficient location of surface facilities and dumps

On the basis of the conducted research, the conclusion is drawn that the most efficient way of enhancing natural wind-exchange is the maximum possible vacation of the area adjacent to an open pit from various facilities including waste dumps. In some cases (for example, while arranging new open pits in flat areas), efficient location of dumps and surface facilities may have an appreciable effect that cannot be neglected. Fig. 4.4 depicts a scheme of efficient location of surface facilities and dumps that allows enhancing open pit ventilation under any wind direction on the surface. Facilities of surface complex 1 (for example, a concentration plant) and dumps 2, the butt ends of which are located at distance 1 equal to 8...10 of their heights from the open pit edge are used as confusor wings in the scheme. Entry trench 3 is directed toward dominating winds (indicated by an arrow). It is clear that facilities used as aerodynamic screens should not be obstacles otherwise even if the speed increases, a negative result might be achieved because of high dustiness of the air coming to an open pit. At the same time, a positive effect of efficient location of surface facilities can be increased due to entry trench 3 directed towards dominating winds [5].

That is why, deep open pits have a set of means of artificial ventilation able to ensure reliable ventilation of open pits even under unfavourable meteorological conditions.

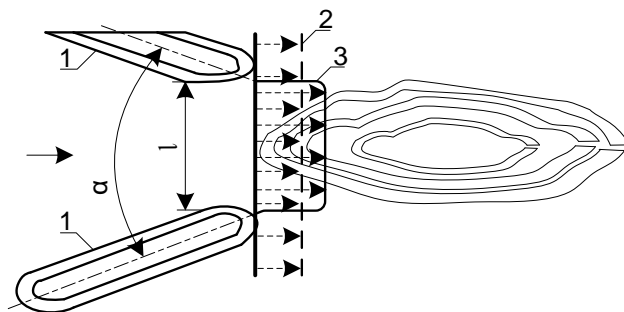

Figure 4.3 – Wind intake scheme: 1 – dumps; 2 and 3 – curves of wind flow speeds above an open pit without and with the wind intake

Waste dumps and facilities located in front of an open pit at the windward side increase wind turbulence transition, thus, increasing the disclosure angle of the wind flow coming to an open pit. The volume of the recirculation area decreases enhancing open pit ventilation. The distance of such dumps from open pits should be no less than their ten heights [6].

Thus, we can draw a conclusion that such conditions for increasing wind flow speeds are sufficient to generate a certain amount of electric energy by a wind power plant.

On the basis of the research results we can assume that constructing system-based WPP with wind engines between open pit dumps is rather expedient.

4.3 Assessment of solar photoenergy potential at open pit dumps of iron ore mining enterprises

To substantiate parameters and modes of SPP operating in small local energy systems (with the capacity of up to a couple of MW or hundreds of kW), for an independent consumer with the capacity of no more than 100-200kW, in case of continuous solar radiation alternation in time (for extremely responsible consumers), the necessary information comprises hourly data on solar radiation coming to a given destination site.

In such cases, one should work out specific methods of calculating hourly solar radiation coming to an arbitrarily oriented receiving site. In order to increase the value of solar radiation access to the receiving site, the latter should be constantly solar-oriented by changing the inclination angle of its surface as to horizon β and the azimuth of the receiving site γ . In this case,

the total solar radiation flow coming to the arbitrarily oriented receiving site during the given time interval Δt , hour is determined by the ratio [39]:

$$E_{\Sigma_i}^{\beta\gamma}(\Delta t) = E_{D_i}^{\beta\gamma}(\Delta t) + E_{\phi_i}^{\beta\gamma}(\Delta t) + E_{R_i}^{\beta\gamma}(\Delta t) \quad (4.16)$$

where $E_{D_i}^{\beta\gamma}(\Delta t) = \bar{R}_{D_i} \Delta t$, $E_{\phi_i}^{\beta\gamma}(\Delta t) = \bar{R}_{\phi_i} \Delta t$, $E_{R_i}^{\beta\gamma}(\Delta t) = \bar{R}_{R_i} \Delta t$. Values of all components in expression (4.18) as in the previously described methods can be re-calculated applying similar components of solar radiation access to the horizontal receiving site. We assume that for any considered point A we choose a valid solar hour as calculated time t without considering time zones. Time should be considered while calculating a consumer's capacity balance in time [30-40].

Let us study the sequence of calculating all expression components separately (4.17).

Direct solar radiation for $\Delta t = 1$ (hour) can be calculated by the formula [39]:

$$E_{D_i}^{\beta\gamma}(\Delta t) = (E_{\Sigma_i}^g - E_{d_i}^g) K_D \quad (4.17)$$

where K_D is the coefficient determined by the ratio:

$$K_D = \frac{\int_0^{T_{\beta\gamma}} R_D^{\beta\gamma}(t) dt}{\int_0^0 R_D^g(t) dt} \quad (4.18)$$

$$E_{D_i}^{\beta\gamma}(\Delta t) = (E_{\Sigma_i}^g - E_{d_i}^g) K_D \quad (4.19)$$

where $R_D^{\beta\gamma}$ and R_D^g is the capacity.

We can draw a conclusion that reflected solar radiation coming to

the arbitrarily oriented receiving site $E_R^{\beta\gamma}$ can be determined by the equation:

$$E_R^{\beta\gamma} = 0,5 E_{\Sigma}^r \rho \sin \beta \quad (4.20)$$

Total solar radiation coming to the arbitrarily oriented receiving site $E_{\Sigma}^{\beta\gamma}$ for any calculated time interval can be found by the formula:

$$E_{\Sigma}^{\beta\gamma} = (E_{\Sigma}^r - E_D^r) K_D + E_D^r \frac{180^0 - \beta}{180^0} + 0,5 E_{\Sigma}^r \rho \sin \beta \quad (4.21)$$

The obtained expression is different in a way from the formula suggested by B.Y. Liu and R. C. Jordan in 1962 and modified in 1976 by S. A. Klein who showed by experimental calculations and comparison with the data that Liu and Jordan’s methods developed for receiving sites inclined southward (i.e. for $\gamma=0$) can be applied for those inclined southward under $\gamma \leq 45^\circ$ as well.

Based on expressions (4.20) and (4.21), formula assumed by Liu and Jordan under $\beta=0 \ \gamma =0$ looks like:

$$E_{\Sigma}^{\beta} = (E_{\Sigma}^r - E_D^r)K_D + E_D^r 0,5(1 + \cos \beta) + 0,5E_{\Sigma}^r \rho(1 - \cos \beta) \quad (4.22)$$

For reflected radiation under $0 \leq \beta \leq 90^\circ$ the indicated contradiction does not exceed 20% and under $\beta=90^\circ$ it can reach 100% ($\beta=180^\circ$).

The main reason for the growing interest to solar energy is the falling prime cost of generated electric energy. Twenty years ago, generation of 1kW costs 1 euro. Today, in sunny countries, 1kW costs less than 10cents and in some regions – 6-7cents.

Possible functioning of SPP and its specific character at iron ore mining enterprises were analyzed.

The conducted analysis in regions of iron ore mining enterprises allows us to conclude that applying SPP both independently and within the electric supply system is reasonable and quite profitable.

The research of open pit insolation of iron ore enterprises resulted into the following picture [41].

Annual average insolation is favourable while the area of iron ore enterprises’ dumps is not usually used. If the area of the shop roof is sufficient, it can also be used.

The research results provide places of possible installation of SPP on the premises of iron ore mining enterprises.

On the assumption of the conducted research, SPP can be introduced at iron ore enterprises. Possible places of SPP installations include tailing ponds, roofs of workshops and industrial premises, landscapes and iron ore enterprises’ dumps.

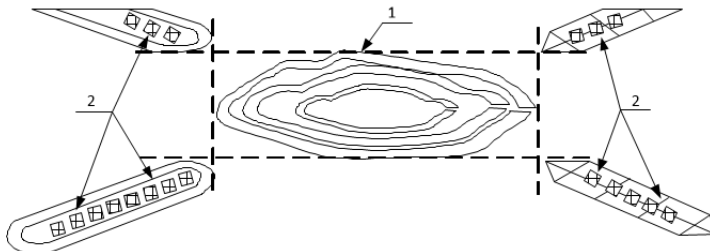

Figure 4.4 – The chart of SPP installation at iron ore dumps: 1 – open pit, 2 – SPP

In spite of the sufficient potential of insolation (especially in Kryvbas), there are some unfavourable factors hindering SPP exploitation at iron ore enterprises.

4.4 Peculiarities of scheme solutions for applying wind power plants at iron ore enterprises

There is a suggested and developed scheme of a wind power plant to be introduced at iron ore mining enterprises (Fig. 4.5).

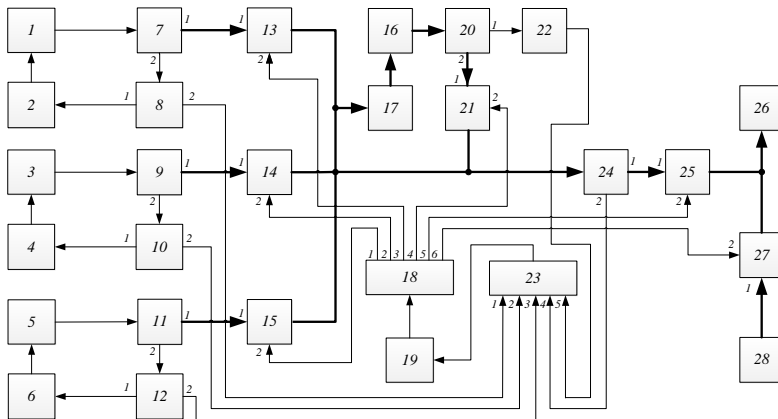

Figure 4.5 – Structural scheme of the electrical-technical complex of a wind power plant at iron ore mining enterprises for their own energy supply: 1- block-systems of the first wind power plant control; 2 – the first adjusting device; 3 – block-systems of the second wind power plant control; 4 – the second adjusting device; 5 – block-systems of the third wind power plant control; 6 – the third adjusting device; 7 – the first wind power plant; 8 – the first block of transducers; 9 – the second wind power plant; 10 – the second block of transducers; 11 – the third wind power plant; 12 – the third block of transducers; 13 – the first controlled disconnector; 14 – the second controlled disconnector; 15 – the third controlled disconnector; 16 – a charging device; 17 – a rectifier; 18 – an output adjusting device; 19 – a computing machine; 20 – storage batteries; 21 – an invert circuit; 22 – a charging transducer; 23 – an input adjusting device; 24 – the fourth block of transducers; 25 – a controlled disconnector of voltage connection; 26 – voltage; 27 – a controlled disconnector of network connection; 28 – the electrical grid.

A wind power plant functions as follows. WPP blocks (7, 9, 11) generate electric energy to be transmitted to the common bus through controlled disconnectors (13, 14, 15).

Under the standard mode when generation parameters are within acceptable standards, the common bus supplies an enterprise's consumers 26 together with network block 28 through controlled disconnector 25. Storage batteries 20 are charged by the common bus through rectifier block 17 and charging device block 16. The transducer blocks which include typical transducers of the current, voltage, line frequency and wind speed (8, 10, 12) through adjusting devices (2, 4, 6) which are to adjust signals, transmit output parameters of blocks (13, 14, 15) to blocks of systems controlling wind power plants (1, 3, 5). Blocks (1, 3, 5) analyze these output parameters and transmit the signal to regulate blocks (7, 9, 11). Blocks (8, 10, 12) and charging transducer 22 through input adjusting device 23 transmit a signal to computing machine block 19. If output parameters of blocks (7, 9, 11) do not meet limit standards (the emergency mode) block 19 transmits a controlling signal to the commutation of blocks (13, 14, 15). If block 28 is under the emergency mode, block 19 transmits a controlling signal to the commutation of the controlled disconnector of network connection 27 and block 26 is supplied only by blocks (7, 9, 11). If there is deficiency of generated capacity, block 19 transmits a controlling signal to invert circuit block 21, generation capacity equalizes due to delivering accumulated energy to the local grid from block 20 through block 21. After eliminating the emergency mode of block 28, block 19 transmits a controlling signal to block 27 to attach block 28 to block 26. In other words, the normal mode is restored.

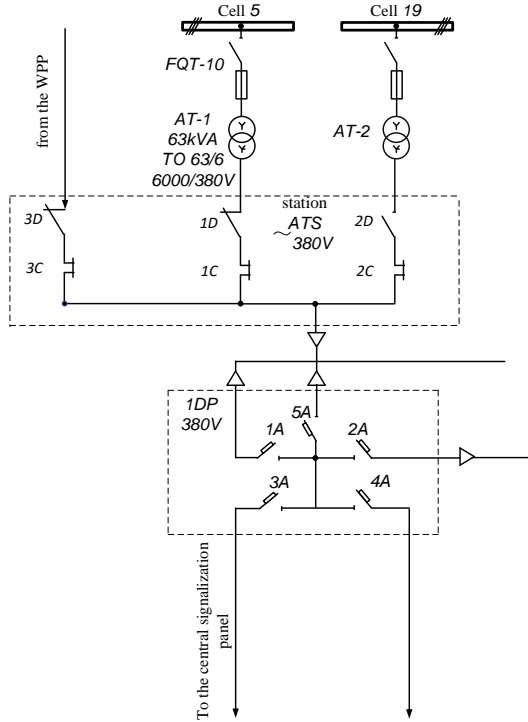

Figure 4.6 – Modernized energy supply scheme of the PJSC “Poltavskiy GZK”

Thus, the electrical-technical energy-supply complex enhances high-level regular energy-supply by introducing wind power plants into an enterprise’s energy-supply system.

Fig. 4.6 depicts a modernized energy-supply scheme of the distribution circuit of the main step-down substation (MSDS) 4/1 of the PJSC “Poltavskiy GZK”. The auxiliary transformer AT-2 is in the cold reserve, AT-1 is planned to be in the hot reserve.

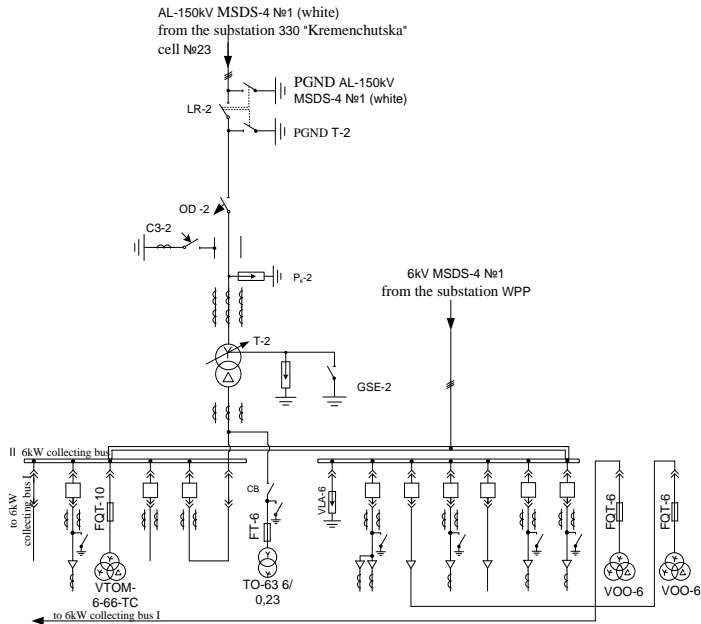

Figure 4.7 – The one-line scheme of electrical connections of the MSDS 4/1 (step-down)

The second variant suggested installing a wind power plant with three wind generators of 450kW (Wind World W150/27) at the western dump, the capacity of each generator being 150kW. The WPP will be attached to the second bus section of the 6kW MSDS 4/1 (step-down). In other words, the plant will supply the enterprise network with generated energy [8] (Fig. 4.7).

4.5 Peculiarities of scheme solutions while applying solar power plants at iron ore mining enterprises

The presented schemes allow creating a structural scheme of an electrical-technical complex of a solar power plant for mining enterprises (Fig. 4.8).

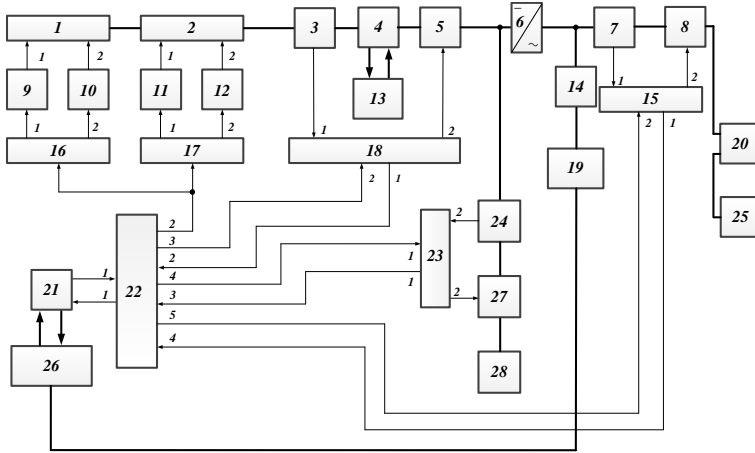

Figure 4.8 – The structural scheme of the electrical-technical complex of a solar power plant for iron ore mining enterprises

The electrical-technical complex of a solar power plant for mining enterprises includes: 1 – the first solar panel; 2 – the second solar panel; 9 – the cleanup system (dust protection) of the first solar panel; 11 – the cleanup system (dust protection) of the second solar panel; 10 – the tilting system of the first solar panel; 12 – the tilting system of the first solar panel; 3 – transducer blocks of the solar power plant; 7 – the voltage transducer blocks; 24 – the block of transducers; 4 – the charging controller; 5 – controlled contacts of the solar power plant; 8 – controlled contacts of a.c. voltage, 27 – controlled contacts; 6 – the inverter module; 13 – storage batteries for auxiliaries; 14 – the charging device; 15 – the interface module of a.c. voltage; 16 – the interface module of the first solar panel; 17 – the interface module of the second solar panel; 18 – the interface module of the solar power plant; 23 – the interface module of DC voltage; 19 – traction batteries; 20 – the main step-down substation; 21 – the computing machine block; 22 – the input-output device; 25 – the grid; 26 – the distance control; 28 – the DC voltage.

The electrical-technical complex functions as follows. Solar panel blocks (1, 2) form a line and generate electric energy. The generated energy goes through charging controller (4). Then the energy goes to charge storage batteries for auxiliaries (13) and blocks of controlled contacts (5, 7) aimed to regulate connection and disconnection of solar panels to the inverter. The AC energy is transmitted to transducers block (24) and block of controlled contacts (27) and goes to DC voltage (28). The generated energy is transmitted to inverter (6). After being transformed from DC into AC, it goes

to main step-down substation (20). Next network block (25) is connected to busses of the main step-down substation. Block (6) is attached to charging device block (14) which charges traction batteries (19) supplying distance control (26) and computing machine (21) with energy. Block (21) transmits a controlling signal to the commutation of blocks (1, 2) due to block (5) and through input-output device (22) – to the commutation of AC controlled contacts (8). Then the signal is transmitted to the commutation of DC controlled contacts (27). Energy parameters are controlled by blocks of transducers (3, 7, 24) which their values to blocks of interface modules (15, 18, 23). These blocks transmit the data to input-output device (22) and next to computing machine (21). Tilting system (10, 12) and cleanup system (9, 11) are controlled by interface modules of solar panels (16, 17). The controlling signal goes from block (21) to block (22) and directly to blocks (16, 17).

4.6 Peculiarities of scheme solutions while introducing Micro Grid at iron ore mining enterprises

Some works consider energy efficiency and saving by using renewable energy sources at mining enterprises [39].

Basic advantages of electric energy consumption at mining enterprises include the opportunity of independent energy generation, optimization of energy use depending on instant prices, increase of energy supply reliability, adjustment to the daily energy system schedule through applying systems controlling voltage, equalization and consumption schedules.

Fig. 4.9 presents a recommended variant of the intellectual energy-supply system. It includes the block of renewable energy sources where HPP is a hydropower plant, WPP is a wind power plant, SPP is a solar power plant and other types of electric energy (EE) sources); the block of the control system (CS Smart); the network block, the block of the adjusting device (AD block); the block of consumers' adjusting devices (AD of consumers), the elements of controlled commutators (C, CC), the inverter (I), the Internet block, the block of storage batteries (SBB), the active consumer (AC), the blocks of transducers (BT), the block of commutation control.

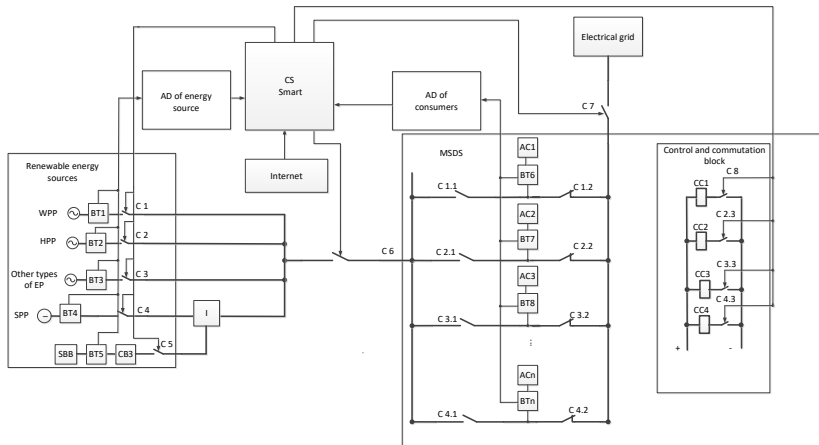

Figure 4.9 – The intellectual energy-supply system of iron ore mining enterprises

The intellectual system functions as follows. In the block of renewable energy sources, there are several types of renewable energy sources, each of them having its own block of transducers connected to the adjusting device which is connected to the control system on the basis of the Smart Grid concept.

The system has a conventional energy source as well as renewable ones (wind, solar and hydropower plants, etc).

According to the required voltage, one chooses a plant which generates electric energy at the given moment and in the required quantity. The control system attaches one of the renewable energy sources through commutation devices to an active energy consumer or consumers.

Thus, the above results of possible RES introduction at mining enterprises [41-43] and the ones of our research indicate the topicality and substantiation for active energy consumption according to the Smart Grid concept at mining enterprises.

List of references for chapter 4

1. World Energy Outlook –2015, OECD/IEA, Paris.
2. Yenergetichna strategiya Ukraïni na period do 2035 r. [Yelektronniy resurs] // Sayt Ministerstva energetiki ta vugilnoiï promislivosti Ukraïni – Rezhim dostupu do resursu: <http://mpe.kmu.gov.ua>.
3. Golitsyn M. V. Alternativnye energonositeli / M. V. Golitsyn, A. M. Golitsyn, N. V. Pronina. – Moskva: Nauka, 2004. – 159 s.
4. Denisenko G. I. Vozobnovlyaemye istochniki energii / G. I. Denisenko. – Kiev: Vishcha shkola, 1983. – 168 s.

5. Labeysh V. G. *Netraditsionnye i vobnovlyayemye istochniki energii* / V.G. Labeysh. – Sankt-Peterburg: SZTU, 2003. – 80 s.
6. *Energeticheskie resursy mira*; pod red. P. S. Neporozhnogo, V. I. Popkova. – Moskva: Energoatomizdat, 1995. – 232 s.
7. Shulga V. G. *Osnovni rezultati ta zavdannya vprovadzhennya netraditsiynikh ta vidnovlyuvanikh dzherel energii v Ukraïni* / V. G. Shulga, B. P. Korobko, M. M. Zhovmir. // *Energetika I elektrifikatsiya*. – 1995. – №2. – S. 39–42.
8. Golitsyn M. V. *Alternativnye energonositeli* / M. V. Golitsyn, A. M. Golitsyn. – Moskva: Nauka, 2004. – 159 s.
9. Stogniy B. S. *Osnovni parametri energozabezpechennya natsionalnoï ekonomiki na period do 2020 roku* / B. S. Stogniy, O. V. Kirilenko, A. V. Prakhovnik. – Kiïv: Vid. In-tu elektrodinamiki NAN Ukraïni, 2011. – 275 s.
10. Samoylov M. V. *Osnovy energosberezheniya. Uchebnoe posobie* / M. V. Samoylov, V. V. Panevchik, A. N. Kovalev. – Minsk: BGEU, 2002. – 98 s.
11. Prakhovnik A. V. *Energoberegayushchie rezhimy elektrosnabzheniya gornodobyvayushchikh predpriyatiy* / A. V. Prakhovnik, V. P. Rozen, V. V. Degtyarev. – Moskva: Nedra, 1985. – 232 s.
12. Kachan Yu. G. *Metodicheskie osnovy povysheniya energoeffektivnosti sistemy elektrosnabzheniya promyshlennykh predpriyatiy* / Yu. G. Kachan, V. V. Dyachenko. // *Girnichya elektromekhanika ta avtomatika: Nauk.-tekhn.zb.*. – 2006. – №76. – S. 12–17.
13. *Smart Power Grids – Talking about a Revolution* // IEEE Emerging Technology portal, 2009.
14. Ovcharenko A. S. *Povyshenie effektivnosti elektrosnabzheniya promyshlennykh predpriyatiy* / A. S. Ovcharenko. – Kiev: Tekhnika, 1989. – 287 s.
15. Sinchuk O. N. *Energoeffektivnost zhelezorudnykh proizvodstv. Otsenka, praktika povysheniya: monografiya* / O. N. Sinchuk, I. O. Sinchuk, E. S. Guzov. – Kremenchug: LAP LAMBERT Academic Publishing is managed by OmniScriptum Management GmbH, 2016. – 346 s.
16. Prakhovnik A. V. *Malaya energetika: raspredelennaya generatsiya v sistemakh energosnabzheniya* / A. V. Prakhovnik. – Kiev: Osvita Ukraïni, 2007. – 464 s.
17. Kudrya S. O. *Atlas energetichnogo potentsialu vidnovlyuvanikh ta netraditsiynikh dzherel energii Ukraïni* / S. O. Kudrya, L. V. Yatsenko, G. P. Dushina. – Kiïv, 2001. – 41 s. – (NAN Ukraïni, derzhavniy komitet Ukraïni z energoberezhennya).
18. *Doslidzhennya vitrovogo rezhimu Ukraïni, viyavleniya osnovnykh*

- klimatoutvoryuyuchikh faktoriv globalnogo i regionalnogo mashtabiv, yaki obumovlyuyut suchasni osoblivosti vitrovogo rezhimu Ukraïni. // Analiz danikh dovgostrokovikh sposterezhen vitropotentsialu na gidrometeorologichnikh stantsiyakh Ukraïni / – Kiïv, 2001. – (MNTTs vitroenergetiki NANU). – (Zvit z NDR; t. 1). – S. 136.
19. Lyashkov V. I. Netraditsionnye i vozobnovlyaemye istochniki energii: Uchebnoe posobie / V. I. Lyashkov, S. N. Kuzmin. – Tambov: Izd-vo Tamb. gos. tekhn. un-ta, 2003. – 96 s.
 20. Kinash R. I. Vitrove navantazhennya i vitroenergetichni resursi v Ukraïni / R. I. Kinash, O. M. Burnaev. – Lviv: Vidavnistvo naukovo-tekhnichnoï literaturi, 1998. – 1152 s.
 21. Kuznetsov M. P. Vpliv roztashuvannya grupi VYeS na rivnomirnist ikh sumisnoï roboti / M. P. Kuznetsov // Vidnovlyuvana energetika KhKhI stolittya: KhIV mizhnar. konf., 16–20 veresnya 2013 r.: tezi dop. / M. P. Kuznetsov. – AR Krim, 2013. – S. 334–339.
 22. Ofitsiynyi sayt NYeK «Ukrenergo» [Yelektronniy resurs] – Rezhim dostupu do resursu: <http://www.ukrenergo.energy.gov.ua>.
 23. Kudrya S. O. Netraditsiyini ta vidnovlyuvani dzherela energii: Pidruchnik / S. O. Kudrya. – Kiïv: Natsionalniy tekhnichniy universitet Ukraïni («KPI»), 2011. – 494 s.
 24. Sonyachna energetika / V. I. Visarionov, G. V. Deryugina, V. A. Kuznetsova, N. K. Malinin. – Moskva: Izdatelskiy dom MEI, 2008. – 277 s.
 25. Sinchuk I. O. Vidnovlyuvani ta alternativni dzherela energii: navchalniy posibnik / I. O. Sinchuk, S. M. Boyko, O. Ć. Melnik. – Kremenchuk: Vidavnistvo PP Shcherbatikh O.V., 2015. – 270 s.
 26. Sinchuk I. O. Potentsial elektroenergoeffektivnosti i puti ego realizatsii na proizvodstvakh s podzemnymi sposobami dobychi zhelezorudnogo syrya: monografiya / I. O. Sinchuk, E. S. Guzov, A. N. Yalovaya; pod red O.N. Sinchuka. – Kremenchug: PP Shcherbatikh O.V., 2015. – 296 s.
 27. Vidnovlyuvani ta alternativni dzherela energii: navchalniy posibnik / O. M. Sinchuk, I. O. Sinchuk, S. M. Boyko, O. Ć. Melnik. – Kremenchuk: PP Shcherbatikh O.V., 2015. – 270 s.
 28. Kharitonov V. P. Avtonomnye vetroelektricheskie ustanovki / V. P. Kharitonov. – Moskva: GNU VIESKh, 2006. – 280 s.
 29. Bril A. O. Yenergetichna sumisnist vitroelektrostantsiy v skladi tsentralizovanoi elektroenergetichnoi sistemi / A. O. Bril, V. P. Vasko, P. F. Vasko // Netraditsionnaya energetika v XXI veke: III mezhdunar. konf.: tezi dop. / A. O. Bril, V. P. Vasko, P. F. Vasko. – AR Krym: ITTF NANU, 2002. – S. 113–115.
 30. Golovko V. M. Analiz printsipiv pobudovi lokalnikh sistem energo-

- zabezpechennya na bazi vidnovlyuvalnikh dzherel energii / V. M. Golovko, P. L. Denisyuk, V. M. Kirilenko // Vidnovlyuvana energetika KhKhI stolittya: IKh mizhnar. konf., 15–19 veresnya 2008 r.: tezi dop / V. M. Golovko, P. L. Denisyuk, V. M. Kirilenko. – AR Krim, 2008. – S. 124–125.
31. Kirik V. V. Doslidzhennya vplivu dzherel rozpodilenoï generatsii na rezhim roboti elektrichnoï sistemi / V. V. Kirik, O. S. Gubatyuk, V. I. Mossakovskiy // Materiali XIV Mizhnar. konf. «Vidnovlyuvana energetika KhKhI stolittya» / V. V. Kirik, O. S. Gubatyuk, V. I. Mossakovskiy. – Krim, 2013. – S. 141–143.
32. Kudrya S. O. Doslidzhennya efektyvnosti kombinovanogo vikoristannya energii vitru, sontsya i teploti zemli dlya otrimannya vodnyu pri elektrolizi vodi / S. O. Kudrya, Yu. P. Morozov, M. P. Kuznetsov // Voden v alternatyvnyi energetitsi ta novitnikh tekhnologiyakh: tezi dop. naukovoi zvitnoi sesii NAN Ukraïni / S. O. Kudrya, Yu. P. Morozov, M. P. Kuznetsov. – Kiïv, 2013. – S. 30.
33. Lezhnyuk P. D. Otsynuyuvannya vplivu dzherel vidnovlyuvanoï energii na zabezpechennya balansovoï nadiynosti v elektrichniy merezhi / P. D. Lezhnyuk, V. O. Komar, D. S. Sobchuk. // Visnik Vinnitskogo politekhnichnogo institutu. – 2013. – №6. – S. 45–47.
34. Lezhnyuk P. D. Otsynuyuvannya vplivu na yakist funktsiyuvannya lokalnoï elektrichnoï sistemi vidnovlyuvalnikh dzherel elektroenergii / P. D. Lezhnyuk, V. O. Komar, D. S. Sobchuk. // Visnik Kharkivskogo natsionalnogo tekhnichnogo universitetu silskogo gospodarstva imeni Petra Vasilenka. – 2013. – S. 8–10.
35. Sinchuk O. N. K voprosu otsenki potentsiala elektroenergoeffektivnosti podzemnykh zhelezorudnykh proizvodstv / O. N. Sinchuk, E. S. Guzov, A. N. Yalovaya // Optimalne keruvannya elektroustanovkami. Zbirnik naukovikh prats mizhdunarodnoï naukovoi tekhnichnoï konferentsii / O. N. Sinchuk, E. S. Guzov, A. N. Yalovaya. – Vinnitsya, 2013. – S. 96.
36. S. M. Boyko, D. A. Mikhaylichenko, O. V. Dozorenko Sistema keruvannya vitroenergetichnoyu stantsieyu dlya elektropostachannya v umovakh pidpriemstv girnicho-vidobuvnoï galuzi Materiali XIII mezhdunarodna nauchna praktichna konferentsiya «klyuchovi vprosi v svremennata nauka - 2017» Volume 11: Tekhnicheski nauki, Sofiya. «Byal GRAD-BG», 2017 S. 35-37.
37. Boyko S. M. Do pitannya vprovadzhennya kontseptsii aktivnogo spozhivannya elektrichnoï energii v umovakh VAT «Poltavskiy GZK» / S. M. Boyko, S. V. Virvikishka // Vseukraïnska naukovoi-praktichna konferentsiya «Aktualni pitannya girnicho-metalurgiyynogo virobnytstva» Zbirnik tez dopovidey / S. M. Boyko, S. V. Virvikishka. – Kriviy Rig:

- DVNZ «KNU», 2017. – S. 64.
38. Boyko S. M. Sistema upravleniya elektropotrebleniem gornorudnykh predpriyatiy s tselyu povysheniya elektroenergoeffektivnosti dobychi zhelezorudnogo syrya / S. M. Boyko, O. M. Sinchuk, I. O. Sinchuk. // Yelektrodinamika. Naukovo-prikladniy zhurnal. – 2016. – №6. – S. 60–62.
 39. Algoritm viboru netraditsiynikh ta vidnovlyuvalnikh dzherel elektrichnoi energii do lokalnoi sistemi elektropostachannya pidpriemstv girnicho-vidobuvnogo kompleksu / S. M. Boyko, O. M. Sinchuk, I. O. Sinchuk, I. A. Minakov. // Electronics and Communications, Volume 21. – 2016. – №5. – S. 6–13.
 40. Boyko S. M. Osoblivosti elektropostachannya pidpriemstv girnicho-vidobuvnogo kompleksu z vikoristannya vidnovlyuvalnikh dzherel elektroenergii / S. M. Boyko // Vseukraïnska naukovo-praktichna konferentsiyu «Aktualnist pitannya girnicho-metalurgiynogo virobnitstva»: Zbirnik tez dopovidey / S. M. Boyko. – Kriviy Rig: DVNZ «KNU», 2016. – S. 47–48.
 41. Rozen V. P. Formuvannya energoefektivnikh rezhimiv elektrospozhivannya virobnichikh sistem: dis. dokt. tekhn. nauk / Rozen V. P. – Dnipropetrovsk, 2013. – 360 s.

CHAPTER 5

RESEARCH OF AVIONICS RADIO COMMUNICATION CHANNELS

In the modern world, the transmission of information through a radio channel is an integral part of any system, one way or another connected with communication and remote control. A modern radio system should be adapted for signals of various communication standards, easily adapt to new ones, and provide for the use of promising ones.

For modern means of implementing communication channels of radio systems for transmitting information in a wide frequency band, the main problems are [1-6]:

- the reliability of the radio channel used;
- prompt response to the variability of the characteristics of the radio channel used;
- transmission speed information;
- maintaining on the minimum hardware platform most relevant communication standards used or promising for a particular radio system;
- the speed of adjustment to other communication channels, and hardware reconfiguration is necessary;
- the complexity of the work when restructuring to the latest standards;
- the complexity of the maintenance and operation of the radio system;
- the cost of using the radio system, maintaining and adjusting to the latest standards of communication;
- compliance with the requirements of the electromagnetic compatibility standard for each radio channel.

Fulfillment of the requirement to work with various communication standards on a single hardware basis means that the hardware must be independent of the main parameters of the radio channel, namely [7]:

- non-constant frequency of the high-frequency modulated signal;
- the type of modulation;
- the bandwidth of the modulated signal;
- the speed transmission information;
- the channel allocation method;
- the structure and length of the package.

As a result, there is a need to develop new approaches and improve existing ones. On this basis, the purpose of the certification work is to develop a model for the implementation of the radio channel using a software-defined radio system.

To achieve the set goal, the necessary tasks are as follows:

- to analyze existing methods;
- to analyze existing hardware, methods of construction and using;
- to develop a radio channel model;
- to develop methods of hardware construction and methods of signal conversion in radio channel;
- to explore the developed system.

All-Union State Standard of Ukraine was used at the time of registration 3008-2015 [1].

5.1 Problem analysis and research problem

The main problems for modern communication channels in the broadband are:

- reliability of the radio channel used;
- prompt response to the variability of the characteristics of the radio channel used - transmission speed information;
- maintaining on the minimum hardware platform most relevant communication standards used or promising for a particular radio system;
- the speed of adjustment to other communication channels, and hardware reconfiguration is necessary;
- the complexity of the work when restructuring to the latest standards;
- the complexity of the maintenance and operation of the radio system;
- the cost of using the radio system, maintaining and adjusting to the latest standards of communication;
- compliance with the requirements of the electromagnetic compatibility standard for each radio channel.

The reliability of the radio channel being used and the quality of communication between subscribers depends on the conditions of radio-wave propagation. The conditions of radio-wave propagation can vary from single-beam propagation of radio signal within the line of sight, to multipath propagation with multiple reflection from interference (including the ionosphere and earth) in the absence of direct line of sight. Significant is the presence of natural interferences, artificial (intentional and unintentional), the density of radio stations in the frequency band [2, 3, 4]. Based on these conditions, we use the sounding of the radio channel to obtain specific characteristics of the radio broadcasting environment and use the data obtained to optimize the radio system parameters in the current environment. The implementation of the control and changes of the parameters of the radio

equipment in the closed loop of automatic control is solved in adaptive and cognitive radio systems. Such implementation allows partially or completely to eliminate user intervention in standard and predicted conditions [2, 4].

The speed of information transfer is determined by the hardware platform that ensures compliance with the data standards.

The modern radio system needs to be adapted to signals of different communication standards, i.e. with different carrier frequency, channel width, modulation type and data rate. The modern radio system needs to be adapted to signals of different communication standards, ie with different carrier frequency, channel width, modulation type and data rate.

Complying with different standards of communication on a single hardware basis means that the hardware must be independent of the basic parameters of the radio channel, namely [1]:

- non-constant frequency of the high-frequency modulated signal;
- the type of modulation;
- the bandwidth of the modulated signal;
- the speed transmission information;
- the method of channelization;
- the structure and the length of the package.

The realization solution of the radio system, which is the minimum hardware platform and pr - the width of the frequency smog of the modulated signal;

- speed transmission information;
- to the method of channelization;
- Structures i dovigny package.

The solution is to implement a radio system that has a minimal hardware platform and is multi-standard to perform hardware functions for converting high-frequency radio signals in software form, before that the radio system parameters change rapidly depending on the requirements of the work. Ideally, the software of such a radio system should automatically recognize the standard of communication, determine the conditions of reception (transmission) and promptly reconfigure the hardware of the radio station. On this basis, the hardware must have a digital interface for real-time status notification and commands for changing operating parameters [3].

Such a concept is nowadays widely used for the construction of modern mobile communications, fixed and mobile objects of terrestrial radio communication systems, television and radio broadcasting, emergency communications in emergency situations, amateur radio communication, radio sensing systems and others.

The cognitive and adaptive radio system is a further development of the software-defined radio system. The principle of a software-defined radio

system is to perform most of the hardware functions for converting and synthesizing high-frequency signal in programmatic form. In any case, hardware functions remain functions that are not programmatically implemented (signal amplification, antenna device) or ineffective (bandpass filters) [2, 4, 5]. The complexity and cost of switching to the latest communication standards is minimal, since significant hardware transformations are not performed and those that are performed have relatively low cost (with minimal hardware on even complex systems compared to traditional analog systems). In general, the transition process is to install an up-to-date version of the radio system software. The same applies to the optimization of the existing radio system. The main cost is the development and maintenance of radio system software.

The radio frequency analog part of an ideal software-defined radio is defined as a single hardware platform that converts the received high-frequency signal into digital form and the signal transmitted from digital form to high-frequency domain.

In principle, the broadband and multi-standard of the receiver is provided, as the functional circuit does not contain hardware narrow-band selective devices or devices that depend on the carrier frequency and width of the channel. The sensitivity of the receiver depends on the noise factor of the linear part of the receiver, the channel width (bandwidth of the optimal filter) and the signal-to-noise ratio at the input of the detector. The noise factor of the linear part of the receiver is a hardware-dependent value and is determined mainly by the noise factor and the gain of the low-noise amplifier. Selectivity on the channels of false reception and on the adjacent channel can be realized by digital filtering [6].

At relatively low frequencies, the implementation of a such scheme on a modern elemental basis is possible. At high frequencies, problems appear that are reflected in the characteristics of the element base. As it converts high frequency signals, in addition to the useful (often weak) signal, has powerful interference and third-party signals, there are high requirements for the linearity and dynamic range of the input amplifier and the analog-to-digital converter. This problem is solved by using ultra-fast AD converter and digital-to-analog converters. Problems start with frequencies above 400 - 500 MHz. This problem is solved by using ultra-fast analog-to-digital and digital-to-analog converters. Problems start with frequencies above 400 - 500 MHz. Problems can be repaired at frequencies between 400 and 500 MHz.

A monolithic linear amplifier -converter is used to increase the operating frequency, which converts the high-frequency spectrum of the input signal to an intermediate frequency of an analog-digital converter.

Such an implementation can be seen by the example of the AD converter and the chip HMC5640BLC4B [7].

Such implementation is quite simple. High-speed economic analog-digital converter and converter amplifiers provide high quality performance and high dynamic range. However, this implementation has a number of problems associated with high energy consumption and high cost.

The implementation of the so-called circuits for cheap "low-frequency" AD converter does not solve the problem, so we can not deny the characteristics. Building separately low frequency and high frequency channels of the radio system does not solve the problem, as they significantly complicate the system and lead to high system cost.

The issue of constructing a broadband path with the use of modern cheap AD converter can significantly simplify the radio system and obtain solutions to the main problems of modern means of implementation of radio communication channels in the broadband at relatively low cost.

Thus, the results of the literature analysis allow us to conclude that the task of problem solution investigating of the radio system operation in the wide frequency band at low-frequency AD converter and DACs with the implementation of communication standards and electromagnetic compatibility in the conditions of a real radio channel is relevant [8].

5.2 Model element developing of the channel radio

The realization model of the radio channel by means of the electronic equipment of the software-defined radio system in its structure has 3 parts, namely:

- the transmitter;
- the radio wave propagation environment;
- the receiver.

Each of these elements is necessary to build an adequate radio channel model.

The transmitter acts as a transmitter and the emitter of radio waves in the radio propagation medium. The hardware implementation of a typical transmitter includes a digital packet shaper, modulator, and power amplifier.

The processor forms quadrature components of a complex envelope modulated signal that are converted into a real physical signal by a DAC.

The following hardware quadrature modulator performs the technical function of converting the modulated signal spectrum from the main range into the high frequency region. The power amplifier, like the quadrature modulator, performs the technical function of providing the energy potential of the radio line [9].

The effect of the power amplifier on the reliability of the transmission of information over the radio channel is to distort the almost perfect signal of the modulator.

For frequency-modulated signals with a constant envelope of the modulated signal, the effect of the power amplifier is quite small. For linear types of modulation, the amplifier can be amplified and phase distorted in the modulated signal, which affect the width of the spectrum of the amplified modulated signal. and the accuracy of the reception.

The software model of the transmitter comprises an information message and digital signal shaper, a quadrature component shaper of a complex envelope modulated signal with a modulated signal spectrum limiter filter. The test message of a predetermined length can be a pseudo-random sequence of binary characters, a scrambled sequence of pseudo-random characters, and a sequence of identical characters.

The spectrum of the frequency-modulated signal is limited by limiting the spectrum of the digital modulating signal; a Gaussian filter or Nyquist's "reduced cosine" is used to limit the spectrum.

Phase-modulated signal spectrum. as a signal with a linear modulation type. is limited by limiting the spectrum of complex envelopes formed by an ideal digital signal with a rectangular pulse shape. To limit the spectrum, we use the filter "summed cosine" or "root square of summed cosine" Nyquist [10].

It is supposed that the subsequent quadrature modulator and power amplifier do not introduce errors that would affect the accuracy of the reception.

The channel of propagation of radio waves is characterized by the input noise, broadband and narrowband signals of third-party radio waves and reflected signals with a limiting amplitude, phase and delay time.

In the adopted model, the channel propagation of radio waves is reflected by white Gaussian noise, narrowband modulated or unmodulated interference, which may be located in the bandwidth of the useful signal or out of band, and the only reflected signal.

White Gaussian noise is characterized by a constant spectral power density with respect to a single amplitude of the received signal.

A third-party interference signal is characterized by a deterministic amplitude with respect to a single amplitude of the received signal and frequency modulation defined in the electromagnetic compatibility standard ETS-300-113.

The reflected signal is characterized by a constant amplitude with respect to the amplitude of the received signal, a constant delay time and a

constant phase value, unchanged at the stationarity interval of the radio channel and randomly changes at the next stationarity interval.

A useful information signal is characterized by a constant amplitude, phase, and delay time [11].

The signal at the output of the radio propagation channel is an additive mixture of useful modulated signal, third-party modulated signal, reflected signal and white Gaussian noise.

The receiver with a single conversion to a zero intermediate frequency includes an input filter-selector, IBE, demodulator, amplification path and limitation of the spectrum of the demodulated signal of the basic range (quadrature components of the complex envelope modulated signal), ADC, digital optimum digital filter and the main filter digital filter.

The receiver software model includes a demodulator, a demodulated signal amplifier, an ADC, and a detector coupled with an optimal filter.

The input high-pass filter and the receiver's IBE, as well as the transmitter power amplifier, perform the technical function of providing the radio's power potential, and are not depicted in the adopted model.

High-frequency noise filter inputs, as well as noise, demodulator, are represented by the magnitude of the white noise power spectral density at the receiver input. The parameters of the real demodulator are reflected in the adopted model by the amplitude and phase imbalance of the recovered quadrature components of the complex envelope, the offset of the center frequency of the quadrature components relative to true zero, and the high-pass filter, which suppresses the constant component.

The analog-to-digital converter is a completely linear device and within its own dynamic range does not distort the converted signal.

The ADC is characterized by the gain of the quadrature components of the demodulated signal and the N-bit quantizer of the current value of the converted signal [18, 19, 21].

The optimal filter (basic selection filter) of the receiver may have a Nyquist characteristic, a square root of Nyquist, rectangular. Non-coherent optimal digital detector provides the recovery of the digital message on the quadrature components of the received binary frequency-modulated signal, binary and four-level phase modulated signal with relative phase modulation.

Timing synchronization of the detector can be provided both external from the transmitter (ideal) and internal directly by the information signal.

5.3 Development of the mathematical model of the radio channel

There is an external indicator of effectiveness for radio communication system. This is the probability of completing the task. For radio communication system channel is to ensure that the information is transmitted to the receiver, in other words from transmitter to receiver [12].

When transmitting information through physical channels, it is necessary to consider the most important characteristics of the transmission medium, as a signal is received is a result of overriding in the middle of the transmission of the radio signal, in addition to the useful signal has additional components.

This means that, in addition to higher equipment, the most important factor is that you need to increase information and to ensure that you have a reasonable and reasonable time to change.

When looking at the physical channel, it's important to get an accurate mathematical model. There is no need to excuse the simplicity of the model, which allows you to choose the best channel for the real channel, but for the best channel for the channel, you can't get too much trouble.

For the mathematical description of a channel, it is necessary and sufficient to specify the set of signals that can be fed to its input, and for any valid signal set a random process (signal) at its output.

It is possible to specify a random process in one form or another of its probability distribution. Thus, in a continuous channel, you need to set the multidimensional density $w[u]$ of the input process $U(t)$ at the interval of analysis T_a and multidimensional transient density $w[z/u]$ ie the density of implementation of the accepted random oscillation $Z(t)$ (signal + noise) under the condition of transfer implementation $U(t)$. In a communication channel, additive interferences are caused by a variety of reasons and may take many forms, individual implementations that are difficult to consider.

Additive interference causes irreversible signal transformations, and in the absence of additive interference, deterministic linear signal transformations are predominantly inverse. In the presence of even relatively weak additive interference, linear transformations are irreversible.

For this reason, in order to build a radio channel, it is necessary to construct a mathematical model of the signals that are signaled in the radio propagation environment, with the consideration of continuous communication channels [13]:

- an ideal channel with no additive obstacles;
- the channel with additive Gaussian noise;

- the channel with an undetermined phase of the signal and additive noise.

The ideal channel shown in Figure 3.1 is represented by a linear chain with a constant transfer function, usually concentrated in a limited frequency band.

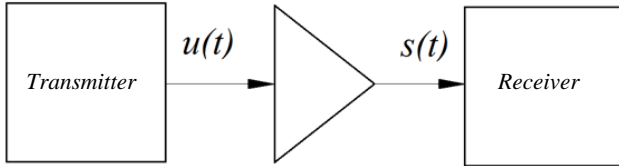

Figure 5.1 – Model of the ideal channel

Any input signal whose spectrum lies in a particular frequency band having a limited average power or peak power is acceptable [14].

In an ideal channel, the output signal $s(t)$ at a given input $u(t)$ is determined and determined

$$s(t) = \gamma u(t - \tau), \tag{5.1}$$

where γ is the constant transmission coefficient of the channel;
 τ - permanent delay.

The channel model with additive Gaussian noise is shown in **Figure 3.2**.

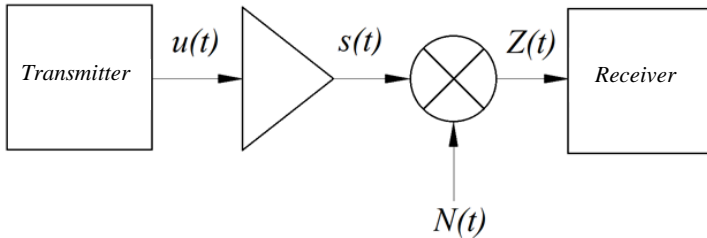

Figure 5.2 – Model channel with additive Gaussian noise

The signal at the output of such a channel:

$$Z(t) = \gamma u(t - \tau) + N(t) = s(t) + N(t), \tag{5.2}$$

Where is $N(t)$ a Gaussian additive noise with zero mathematical expectation and a given correlation function. There is a visible gaussian noise,

or quasi-white with uniform spectral density in the frequency spectrum band $s(t)$ [15].

In the analysis τ , you can not take into account that corresponds to the change in the beginning of the countdown time at the output of the channel.

If the transmission γ and delay ratios τ are known functions of time then function 5.2 looks like

$$Z(t) = \gamma(t)u[t - \tau(t)] + N(t). \quad (5.3)$$

The channel model with an undetermined signal phase and additive noise differs from the 5.2 model in that its delay is a random variable. For narrowband signals, expression 5.2 with constant γ and random τ expression has the form

$$Z(t) = \gamma[\cos \theta u(t) - \sin \theta \hat{u}(t)] + N(t), \quad (5.4)$$

where is $\hat{u}(t)$ - Hilbert transformation from $u(t)$,
 $\theta = -\omega_0 \tau$ random phase.

Probability distributions θ are allowed to be given at a uniform interval from 0 to 2π .

This model satisfactorily describes the same channels as the previous models, provided that the signal phase in them fluctuates. This fluctuation is caused by a small change in the channel length, the properties of the medium in which the signal passes, and the phase instability of the reference generators [16].

A single-beam Gaussian channel with general fading (amplitude fluctuations and signal phases) is also described by formula 5.2, but the multiplier γ , as and a phase θ are considered random processes. This means that the quadrature components will be random.

$$X = \gamma \cos \theta, Y = \gamma \sin \theta. \quad (5.5)$$

When changing quadrature components X, Y in time, the accepted oscillation

$$Z(t) = X(t)u(t) - Y(t)\hat{u}(t) + N(t) = \gamma(t)[\cos \theta(t)u(t) - \sin \theta(t)\hat{u}(t)] + N(t). \quad (5.6)$$

The one-dimensional distribution of the channel transmission coefficient γ may be Rayleigh or generalized Rayleigh. Such channels are called channels with Rayleigh or generalized Rayleigh (Ray) fading. Within

the general Gaussian model of the channel \mathcal{Y} , it has four-parameter distribution.

The fading single-channel model sufficiently describes the large number of radio channels in different wavelengths, as well as some other channels.

Multi-beam Gaussian channel with frequency-selective generalization generalizes the model 5.6

$$Z(t) = \sum_{n=1}^N \gamma_n(t) [\cos \theta_n(t) u(t - \bar{\tau}_n) - \sin \theta_n(t) \tilde{u}(t - \tau_n)] + N(t), \quad (5.7)$$

where N - the number of rays in the channels

$\bar{\tau}_n$ - the average delay time for the n - th ray

5.4 Development of a model of software functions for conversion of received signals of the receiver

Software support of the transceiver in general and the receiver itself implements a software-defined radio system. To operate in a wide range of carrier frequencies, temperatures, and amplitudes of the received signal, of different channel widths, it is necessary to change and adjust the parameters of the basic analog components according to the working standard of communication and real reception conditions.

In addition, it is only possible to compensate for the non-ideality of the analog devices through online parameter control or subsequent digital processing.

Software features can be divided into mandatory and optional. Required features are a set of features without which the stable operation of the radio.

Optional features can be created as optional features solely for the convenience of the operator, and features without which the radio can be operated.

Required functions for the implementation of the functions of the receiver of the software-defined radio system software automatic control [17]:

- the received signal, that is, the automatic gain control function;
- constant component, module and phase of the quadrature components of the complex envelope;
- bandwidth in the main digital range of the linear part of the receiver and the main selection filter.

In addition, in digital form, there are standard operations for clock synchronization and detection.

Automatic adjustment of the receiver gain is intended to prevent the amplitude signal limitation in the analog path of the receiver and the combination of a high dynamic range of change in the amplitude of the received signal with a limited dynamic range of the ADC.

The solution of the first problem is important for modulated signals with concomitant amplitude modulation, the solution of the second problem is necessary for any kind of signal.

The time constant of the automatic control system T_{AGG} is determined by the stationary time of the radio channel T_{ch} . The time constant of a quasi-stationary radio channel is one and tens of milliseconds, corresponding to the time constant of the ADC.

When choosing a time constant, it is important to keep in mind that any change in the amplitude of the received signal in the receiver means the introduction of parasitic amplitude modulation. The additional spectral components resulting from such modulation should be located either in the maximum range of the payload spectrum or outside the payload spectrum.

Necessary elements of the ADC are the RSSI total level sensor and the control loop hysteresis. A natural measure of the level of the input signal is the energy of the received signal in the time interval $T_{AGC} < T_{ch}$, less than the stationary time of the radio channel.

The formal expression for average energy during the analysis is the sum of squares of the quadrature I / Q components in the moving window, the length of T_{AGC} .

$$RSSI_k = \frac{1}{N_{AGC}} \sum_{j=k-N_{AGC}}^k I_j^2 + Q_j^2, \quad (5.8)$$

where $RSSI_k$ - the average energy of the signal received per hour for analysis T_{AGC} ;

T_s - the length of the character interval;

N_s - the number of samples in the character interval.

Hysteresis provides loop stability with automatic adjustment, suppressing parasitic self-oscillations at the transition of the instantaneous value of the amplitude of the received signal of the boundary separating the active and passive mode of operation. That is, the threshold of transition from the active mode of change of the gain to the passive mode of holding the constant gain must differ in magnitude from the threshold of the transition

from the passive mode of holding the constant gain to the active mode of change of the gain.

The correction of the parameters of the quadrature components of the complex envelope modulating signal must be performed under conditions of inevitable asymmetry of the analog quadrature channels of the receiver.

Different values of the module and phase of the gain coefficients of the demodulator channels and operational amplifiers lead to the asymmetry of the amplitude and the constant component of the quadrature component of the envelope complex in the quadrature channels.

The effect of asymmetry of quadrature components on the decrease in the reliability of reception, different for different types of modulation. But for multi-mode operation of the receiver in any case, it is necessary to provide as much as possible the coefficients of gain in the frequency band, in the temperature range and in the technological scattering of the parameters of analog circuits [18].

The direct change of the parameters of the receiver channel equipment (demodulator or amplifiers) in order to symmetry of the channels is practically impossible.

The only real method of achieving maximum reception accuracy is the software correction of the quadrature components of the demodulated signal. Formally, the correction can be made both on the test signal and directly on the information signal. The implementation of the second variant is much more difficult, because the complex envelope signal has a complex shape and a significant noise background.

As a result, the accuracy of the correction will be small and may not actually lead to an increase in the reliability of reception [19].

Much better results are to be expected from algorithms for determining correction coefficients to quadrature I / Q components by a simple test signal that is generated directly when the radio is turned on or at the initial factory setting.

Consider an example implementation of algorithms for the operational determination of parameters and compensation for a small imbalance of amplitude, phase and constant component of the quadrature components of the demodulated signal by ideal test signals [20-21].

It is assumed that when a radio station is switched on or one of the parameters that determine the mode of operation (frequency, temperature) is changed, quadrature monochromatic signals are generated in the radio station, with a carrier frequency that is offset relative to the expected frequency of reception ω_d [22].

The test signal after passing the demodulator, amplifiers and ADC, comes to the processor in the form of quadrature components

$$\begin{aligned} I(t) &= A_I \cos(\omega_d t - \phi / 2) + U_I, \\ Q(t) &= A_Q \sin(\omega_d t - \phi / 2) + U_Q, \end{aligned} \quad (5.9)$$

where A_I, A_Q - the amplitudes of the test quadrature components that are different from the true unit ones;

U_I, U_Q - constant components of the test quadrature components that differ from the true zero value;

ϕ - a phase error that is different from true zero.

The amplitude correction is to determine the minimum and maximum values of each test quadrature component 5.9 in the course of a sufficiently large number of character intervals K .

$$\begin{aligned} AI_{\min} &= \frac{1}{K} \sum_{k=0}^K \min I_k(T_s), \quad AI_{\max} = \frac{1}{K} \sum_{k=0}^K \max I_k(T_s), \\ AQ_{\min} &= \frac{1}{K} \sum_{k=0}^K \min Q_k(T_s), \quad AQ_{\max} = \frac{1}{K} \sum_{k=0}^K \max Q_k(T_s), \end{aligned} \quad (5.10)$$

where $\min I_k(T_s), \max I_k(T_s)$ - minimum and maximum value of common-mode component $I(t)$ for k symbolic interval;

$\min Q_k(T_s), \max Q_k(T_s)$ - the minimum and maximum value of the quadrature component $Q(t)$ on the k symbolic interval.

Formal transformation 5.8, taking into account 5.10, allows us to obtain expressions for the correction coefficients up to the amplitude values and the constant component in each channel

$$\begin{aligned} A_I &= (AI_{\max} - AI_{\min}) / 2, \quad U_I = (AI_{\max} + AI_{\min}) / 2, \\ A_Q &= (AQ_{\max} - AQ_{\min}) / 2, \quad U_Q = (AQ_{\max} + AQ_{\min}) / 2, \end{aligned} \quad (3.11)$$

In the information reception mode, each quadrature component of the demodulated signal $I(t)$ and $Q(t)$ must be modified according to the calculations in the test mode by adjusting the coefficients:

$$\begin{aligned} \tilde{I}(t) &= [I(t) - U_I] / A_I, \\ \tilde{Q}(t) &= [Q(t) - U_Q] / A_Q. \end{aligned} \quad (5.12)$$

Phase correction is required to ensure phase shift between quadrature components $\tilde{I}(t)$ and $\tilde{Q}(t)$ as close to ideal as possible $\pi / 2$. Determining the possible phase shift is to calculate the average of the correlation integral from the test quadrature components 3.13 over the course of a sufficient number of character intervals K [23].

$$\phi = \arcsin \left(2 \int_0^{KT_s} I(t)Q(t)dt \right). \quad (5.13)$$

The magnitude of the phase error, calculated according to 5.13, allows to determine the relationship between the true $\hat{I}(t)$, $\hat{Q}(t)$ and accepted $\tilde{I}(t)$, $\tilde{Q}(t)$ values of the quadrature components using 5.14 in terms of equal amplitudes and zero constant displacement in each channel

$$\begin{aligned} \hat{I}(t) &= \tilde{I}(t)\cos(\phi/2) + \tilde{Q}(t)\sin(\phi/2), \\ \hat{Q}(t) &= \tilde{Q}(t)\cos(\phi/2) + \tilde{I}(t)\sin(\phi/2). \end{aligned} \quad (5.14)$$

After elementary transformation 5.15 we obtain the expression for the true values of the quadrature components of the complex envelope demodulated information signal with the known value of the phase error 5.14

$$\begin{aligned} \hat{I}(t) &= [\tilde{I}(t)\cos(\phi/2) - \tilde{Q}(t)\sin(\phi/2)] / \cos\phi, \\ \hat{Q}(t) &= [\tilde{I}(t)\sin(\phi/2) - \tilde{Q}(t)\cos(\phi/2)] / \cos\phi. \end{aligned} \quad (5.15)$$

Practically, the calculations for 5.15 are reduced to a search in the table of previously calculated coefficients $\cos(\phi/2)/\cos\phi$ and $\sin(\phi/2)/\cos\phi$ according to the magnitude of the phase error 5.14.

List of references for chapter 5

1. GOST 3008 - 2015. State standard of Ukraine. Documentation. Reports in the field of science and technology. Structure and rules of design [Text]: Valid from 06/22/2015
2. Babkin AN, Avsentiev OS Ensuring the functional survivability of the radio channel // Bulletin of the Voronezh Institute of the Ministry of Internal Affairs of Russia: electron. version of the journal. 2012. №3. P.116 - 121 URL: <https://cyberleninka.ru/article/n/providing-of-radio-channel-functional-survivability> (reference date 25.10.2018)
3. A.G. Nesterenko Analysis of the Functioning Conditions of Multichannel Radio Networks and Problems of Optimization of Their Functional Characteristics // Bulletin of the St. Petersburg University of the State Fire Service of the Ministry of Emergency Situations of Russia: electron. version of the journal. 2015. No. 3 (41). Pp. 42 - 47 URL: <https://cyberleninka.ru/article/n/analiz-usloviy-funktsionirovaniya-setey-mnogokanalnoy-radiosvyazi-i-problemy-optimizatsii-ih-funktsionalnyh-harakteristik> (reference date 09/16/2018)
4. A. V. Podlesny, I. G. Brynko, V. I. Kurkin, V. A. Berezovsky Multifunctional LFM ionosonde for monitoring the ionosphere // HELIOGEOGRAPHICAL RESEARCHES: electron. version of the

- journal. 2013. No. 4, pp. 24-31 URL: <http://vestnik.geospace.ru/articles/UPLF4ac.pdf> (reference date September 22, 2018)
5. Galkin V. A. The basics of software-configurable radio. –M.: Hotline - Telecom, 2015. - 372 p.
 6. Panchenko AY, Sezonova IK, Petulko MS, Mikheyev KA The principle of construction of a high-frequency path of a program-defined radio system // International scientific journal "Internauka". - 2018. - №22.
 7. Theory of electrical communication: Textbook for high schools / A. G. Zyuko, D. D. Kloovsky, V. I. Korzhik, M. V. Nazarov; Ed. D.D. Kloovsky. - M.: Radio and Communications, 1999. - 432 p.
 8. USB interface full galvanic isolation (CAT, CW, PTT, RS-232, AUDIO) Alex UY5QO // UR8LV.com: website. URL: <http://www.ur8lv.com/index.php?id=1546928081> (reference date November 27, 2018)
 9. The key mixer on the chip ADG774 // Technical portal of amateur radio: website. URL: http://www.cqham.ru/mix_akt.htm (reference date October 26, 2018)
 10. Preselector // Technical portal of amateur radio: website. URL: http://www.cqham.ru/ew1mm_pr.htm (reference date October 26, 2018)
 11. B.D. Zhenatov Extending the dynamic range of discretization and quantization devices of digital radio reception equipment: dis. on the health sciences. Candidate degree tech. Sciences: [special.] 05.12.17 "Radio engineering and television systems and devices" / Omsk State Technical University. Omsk, 2013.142 p.
 12. V. E Ovcharenko, S. A. Tyshko, V. G. Smolyar, O. E. Zabula, Yu. N. Chernichenko Principles of measuring the phase shift of harmonic signals using a half-wave conversion // Instrument making technology: electron. version of the journal. 2015. No. 1, pp. 54-57 URL: http://journal.nitip.com.ua/media/uploads/documents/14_15.pdf (reference date November 12, 2018)
 13. Key mixers on microcircuits // Technical portal QRZ.ru: website. URL: <http://ra3ggi.qrz.ru/UZLY/rd980138.htm> (reference date 10.11.2018)
 14. K. Ya. Mamedov, V. V. Korna, A. A. Pukhov On the issue of determining the dynamic range of an SDR receiver // Modern Information and Electronic Technologies: Electron. version of the journal. 2013 No. 2 S. 289-292 URL: <http://tkea.com.ua/siet/archive/2013-t1/289.pdf> (reference date November 25, 2018)
 15. Timing signal and synchronization // Analog devices: website. URL: <https://www.analog.com/en/products/clock-and-timing.html> (reference date November 17, 2018)

16. I. Collins Phase-Locked Loop (PLL) Fundamentals // Analog Dialogue: electron. version of the journal. 2018 No. 52. C. 1-6 URL: <https://www.analog.com/en/analog-dialogue/articles/phase-locked-loop-pll-fundamentals.html> (reference date 11/21/2018)
17. P. Holes Locating Passive Intermodulation, PIM Faults // RF TECHNOLOGY & DESIGN: Electron. version of the journal. 2016 pp. 21-32 URL: <https://www.radio-electronics.com/articles/rf-topics/locating-passive-intermodulation-pim-faults-48> (reference date November 27, 2018)
18. Giovanni D`Amore Measuring Noise Figure on RF systems // RF TECHNOLOGY & DESIGN: Electron. version of the journal. 2017 pp. 13-21 URL: <https://www.radio-electronics.com/articles/rf-topics/measuring-noise-figure-on-rf-systems-206> (reference date November 27, 2018)
19. What is PM, Phase Modulation // electronics notes: website. URL: <https://www.electronics-notes.com/articles/radio/modulation/phase-modulation-what-is-pm-tutorial.php> (reference date October 26, 2018)
20. Phase Shift Keying // electronics notes: website. URL: <https://www.electronics-notes.com/articles/radio/modulation/phase-modulation-shift-keying.php> (reference date 10/26/2018)
21. What is Software Defined Radio // Wireless Innovation Forum: Web site. URL: <https://www.wirelessinnovation.org/documents/SoftwareDefinedRadio.pdf> (reference date 10/16/2018)
22. B. D. Zhenatov, A. P. Averchenko, D. V. Astapenko, Choice of an ADC for a digital radio receiver // Actual problems of technical sciences: materials of the III Intern. scientific conf. Perm: Zebra, 2015.S. 43-46. URL <https://moluch.ru/conf/tech/archive/125/7790/> (reference date 10/18/2018)
23. A Panoramic Transceiving System for PSK31 // Radio amateur technical portal: website. URL: http://www.cqham.ru/psk_trx.htm (reference date November 1, 2018)



Sinchuk Ihor Olehovych, PhD (Engineering), Assoc. Prof., Doctoral Candidate of Department of Automated Electrical-Mechanical Systems in Industry and Transport, the Kryvyi Rih National University



Boiko Serhii Mykolaiovych, PhD (Engineering), Doctoral Candidate, Dean of the Faculty of Aviation Transport, Power Engineering and Management, lecturer, Kremenchuk Flight College of Kharkiv National University of Internal Affairs



Gavriyluk Yuriy Mykolayovich, PhD (Engineering), Prof., Lecturer of Department of Aviation and electronic equipment, Kremenchuk Flight College of Kharkiv National University of Internal Affairs



Nekrasov Andrii Viktorovych, PhD (Engineering), Assoc. Prof., Assoc. Prof. of Department of Electric machines and apparatus, Kremenchuk Mykhailo Ostrohradskyi National University



Rykov Hennadiy Yuriyovych, Senior Lecturer of Department of Electric machines and apparatus, Kremenchuk Mykhailo Ostrohradskyi National University



Borisenko Oksana Mykolayivna, Lecturer of Department of Physical and mathematical disciplines and computer science, Kremenchuk Flight College of Kharkiv National University of Internal Affairs



Bilyk Alla Oleksandrivna, Lecturer of Department of Aviation and electronic equipment, Kremenchuk Flight College of Kharkiv National University of Internal Affairs



Petulko Mykhaylo Serhiyovych, Lecturer of Department of Aviation and electronic equipment, Kremenchuk Flight College of Kharkiv National University of Internal Affairs

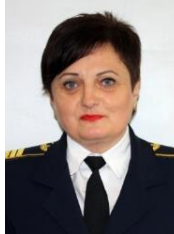

Ivanchenko Lyudmyla Volodymyrivna, Lecturer of Department of Aviation and electronic equipment, Kremenchuk Flight College of Kharkiv National University of Internal Affairs



Zhukov Oleksiy Anatoliyovych, PhD, assistant professor at the Department of automation of electromechanical systems automation in industry and transport, Vinnytsia national technical university

SCIENTIFIC PUBLICATION

Sinchuk Ihor Olehovych
Boiko Serhii Mykolaiovych
Gavrilyuk Yuriy Mykolayovich
Nekrasov Andrii Viktorovych
Rykov Hennadii Yuriyovych
Borisenko Oksana Mykolayivna
Bilyk Alla Oleksandrivna
Petulko Mykhaylo Serhiyovych
Ivanchenko Lyudmyla Volodymyrivna
Zhukov Oleksiy Anatoliyovich

SMART INTELLIGENT AUTOMATION IN POWER SYSTEMS

Edited by Sinchuk O.M., DSc., Prof.

Multi-authored monograph

Subscribe to print 27/06/2020. Format 60×90/16.
Edition of 300 copies.
Printed by “iScience” Sp. z o. o.
Warsaw, Poland
08-444, str. Grzybowska, 87
info@sciencecentrum.pl, <https://sciencecentrum.pl>



ISBN 978-83-66216-32-7



9 788366 216327